

OPTION LINKS

OPTION RECHTS

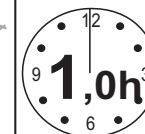

1

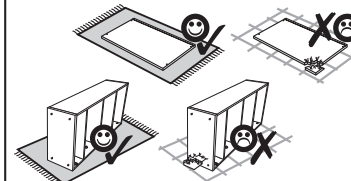
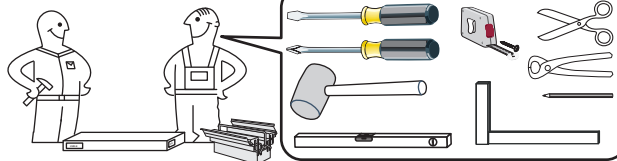
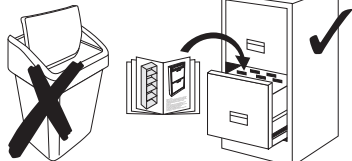
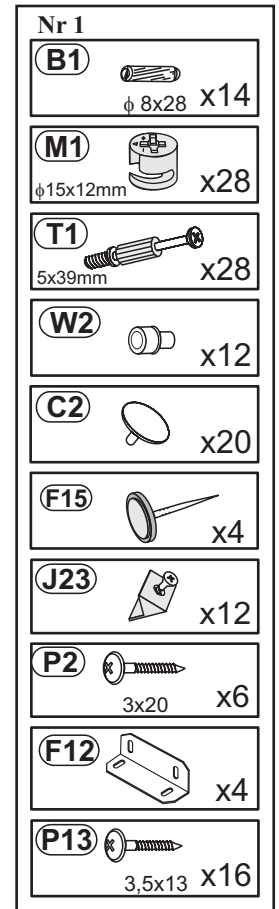
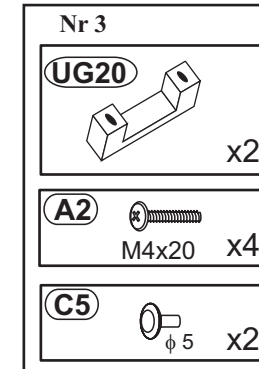
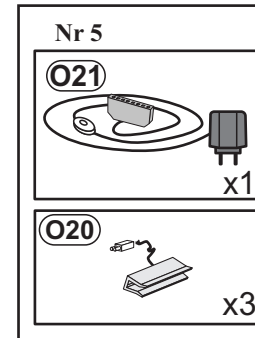
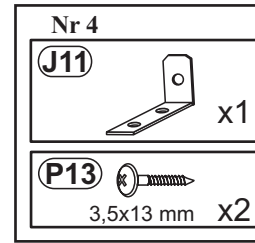
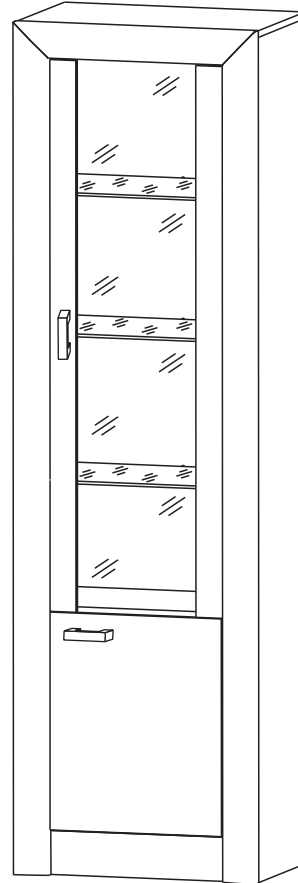
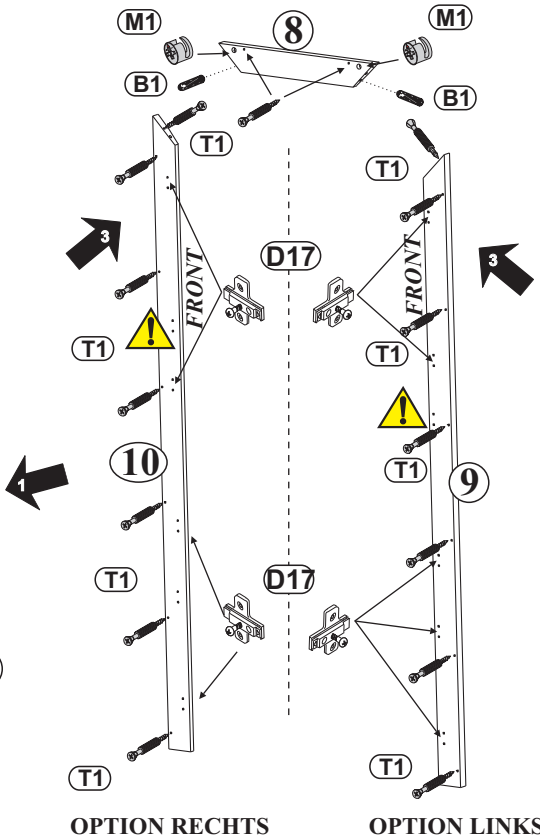
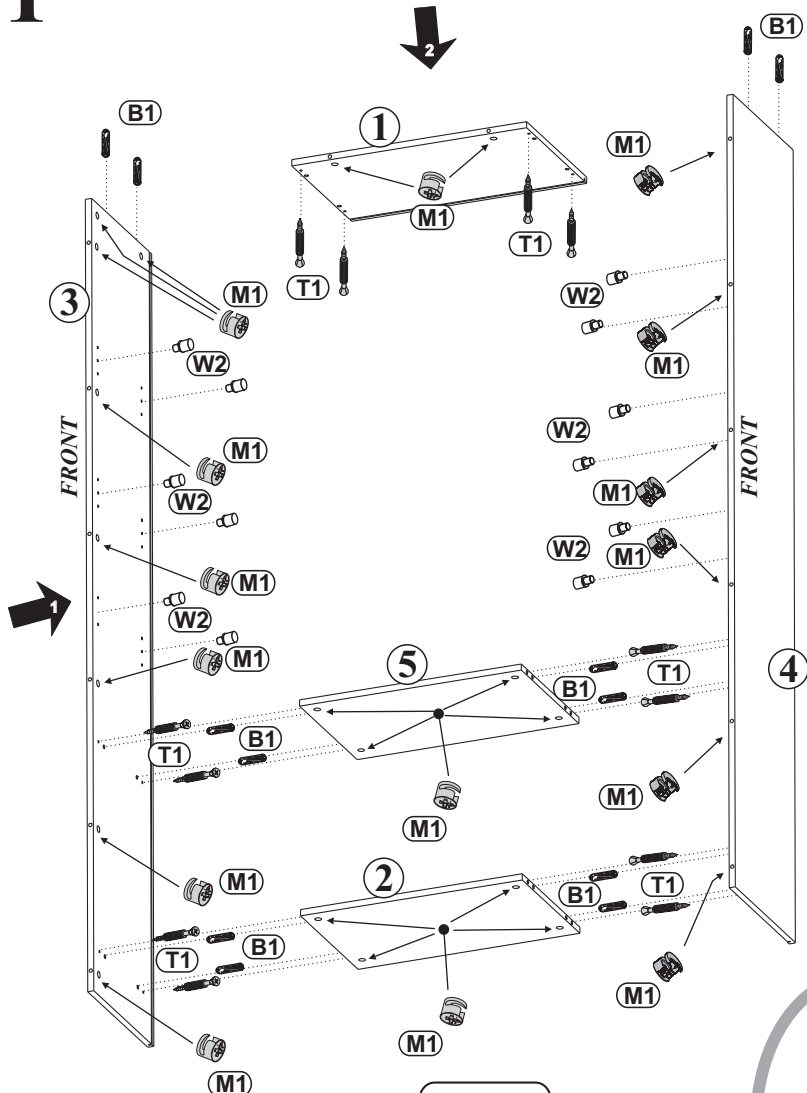

C5 $\phi 5$ x2

B1 $\phi 8 \times 28$ x14

Y17 x5

M1 $\phi 15 \times 12 \text{mm}$ x28

D17 H6 x5

T1 5x39mm x28

E3 6,3x13 x10

W2 x12

S8 4x13 x10

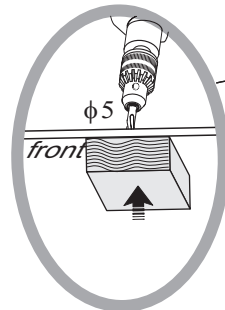
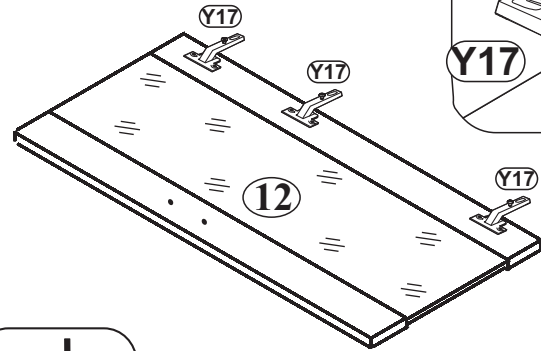
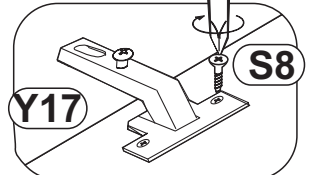
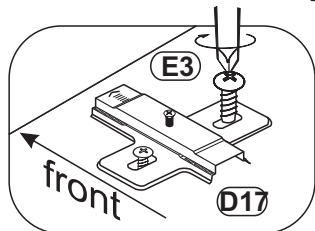

OPTION LINKS

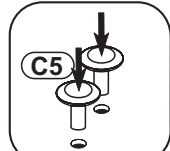
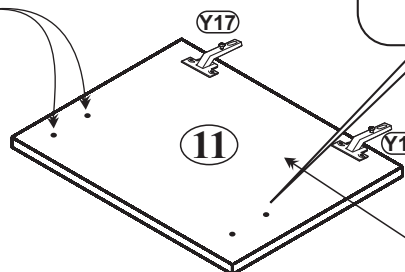

OPTION RECHTS

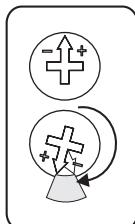
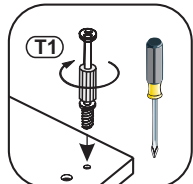
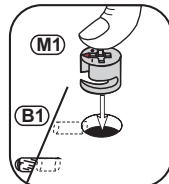
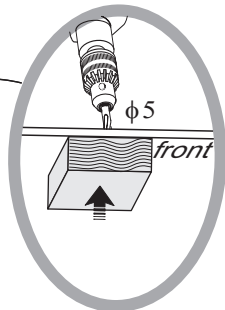
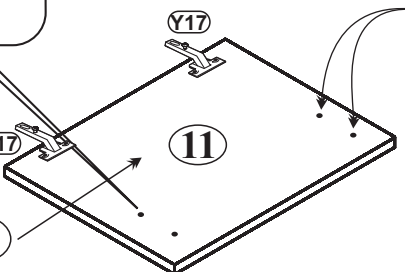

2

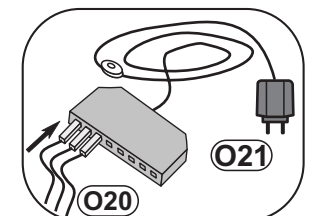
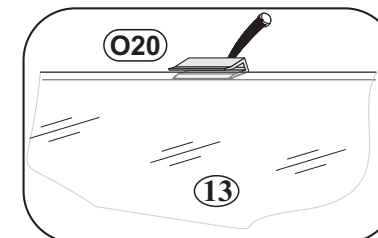
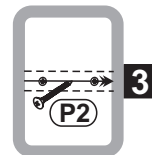
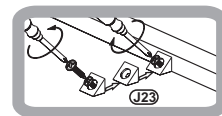
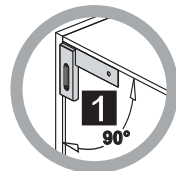
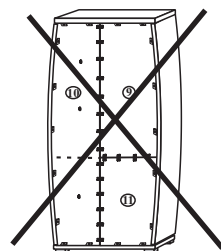
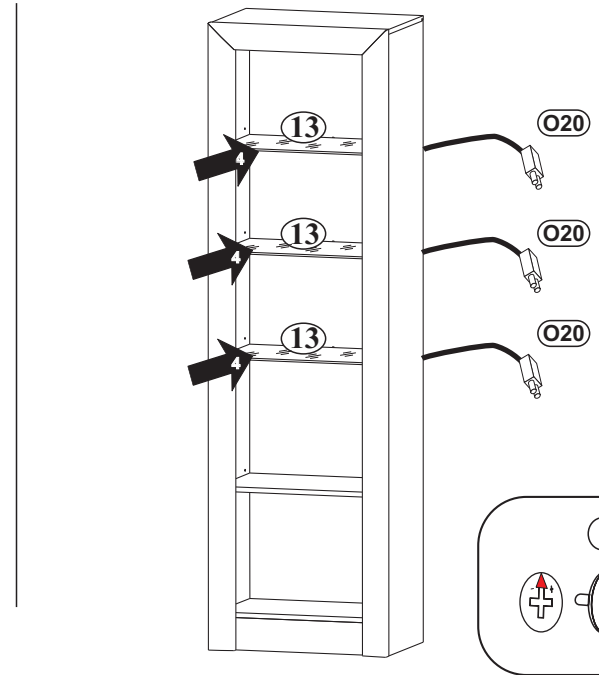
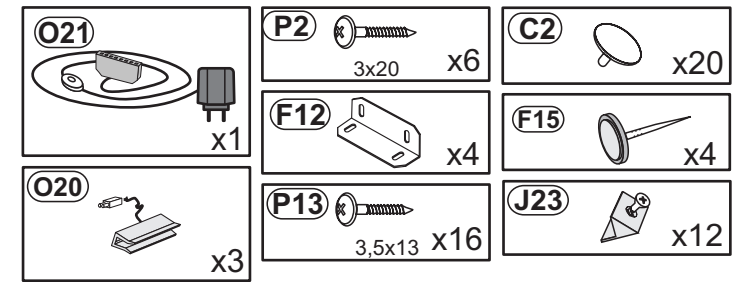
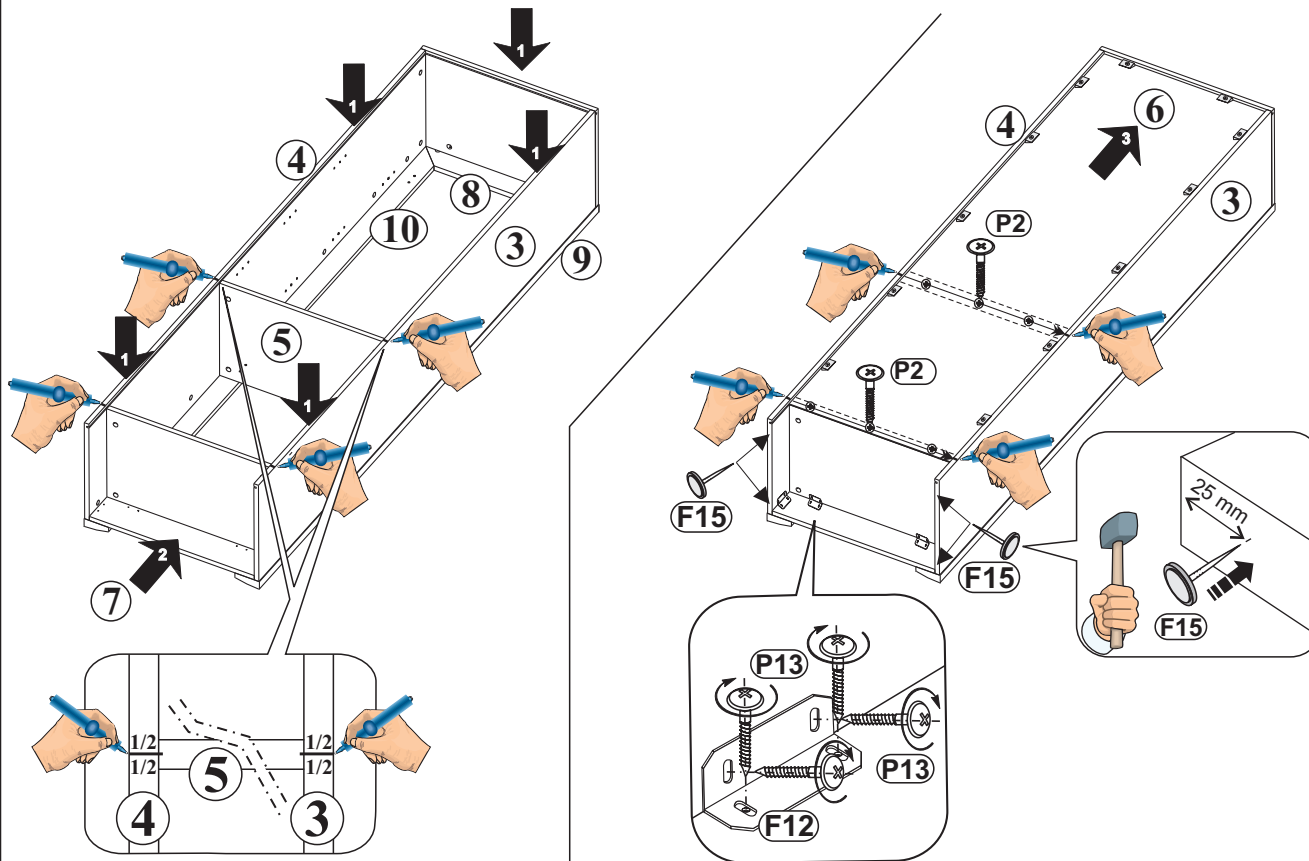

3

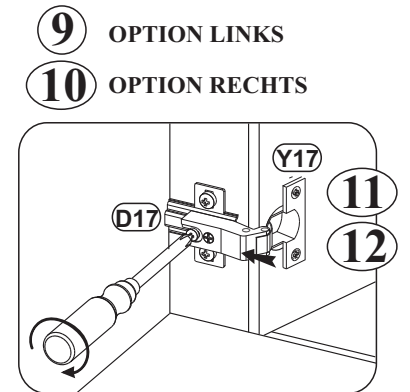
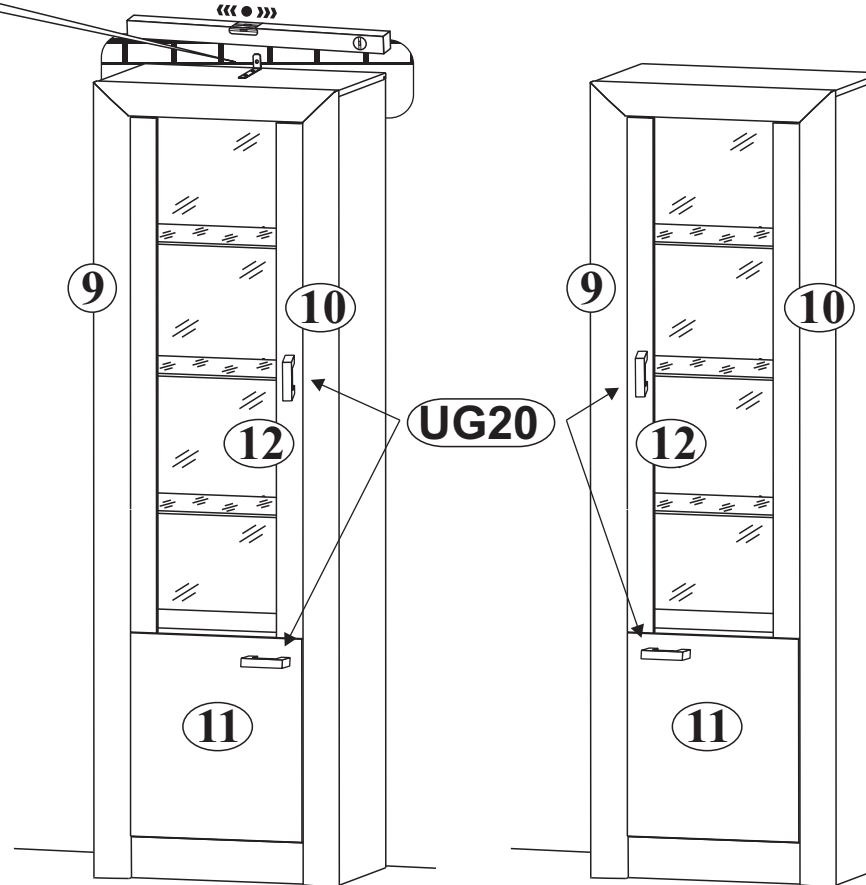
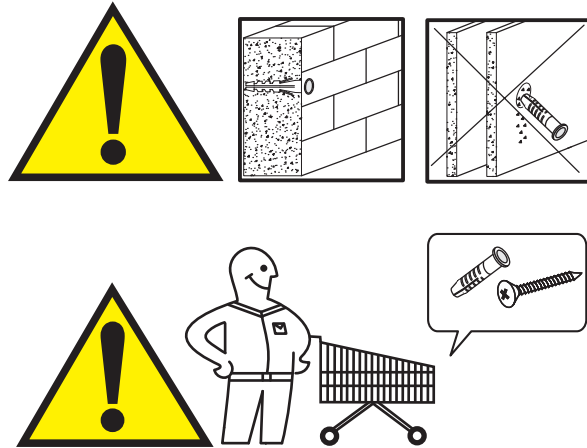
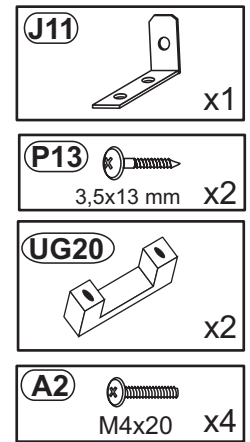
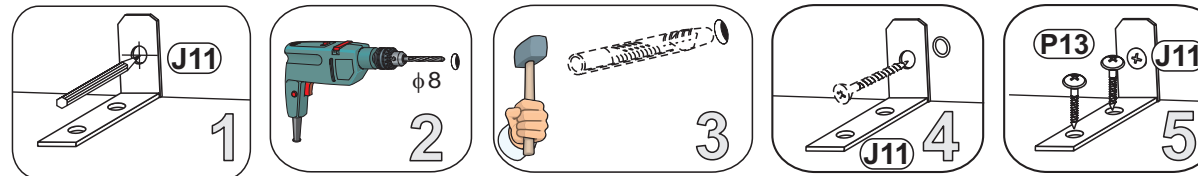
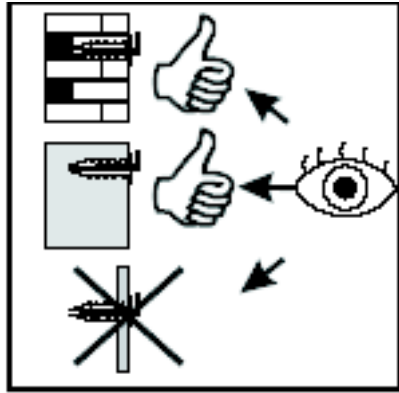

OPTION LINKS

OPTION RECHTS

