

CARMEN

R-9

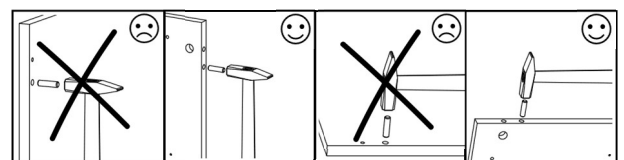

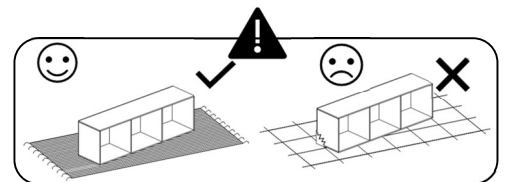
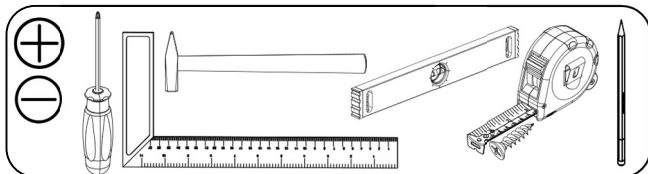
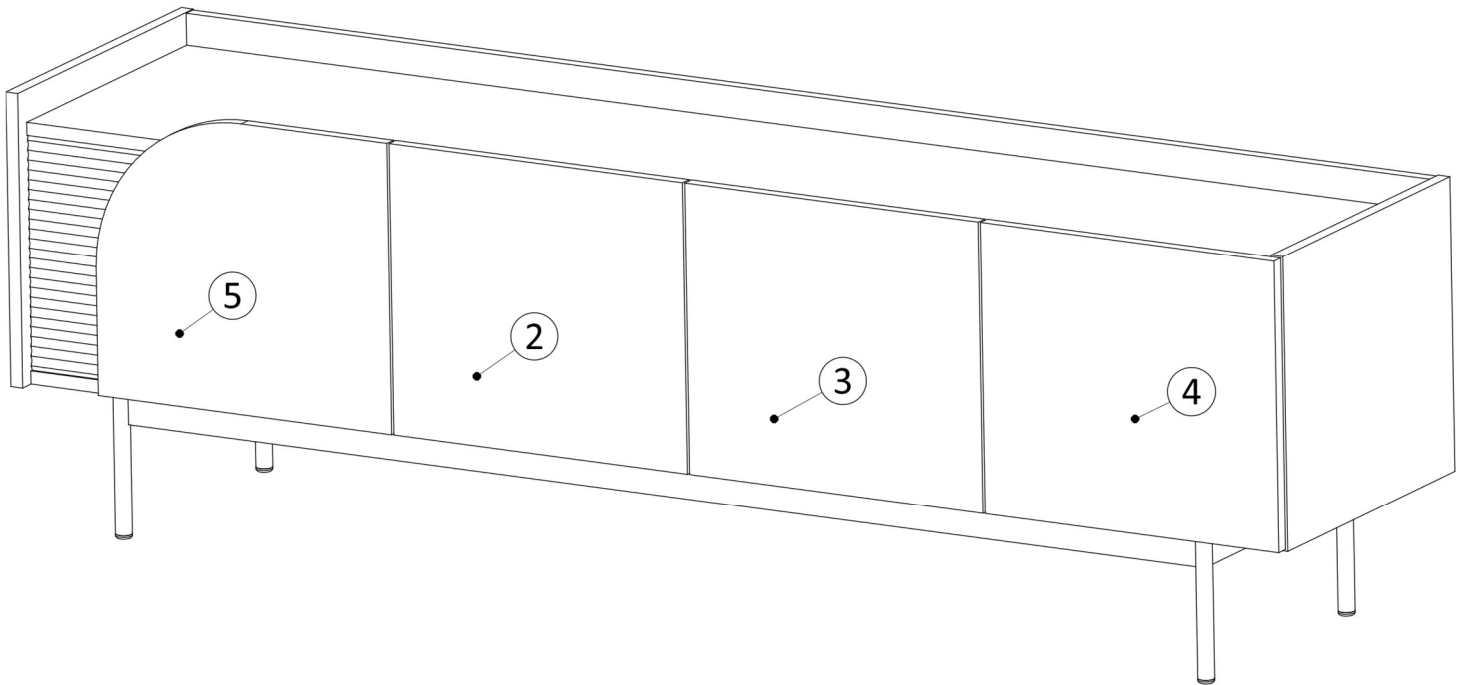
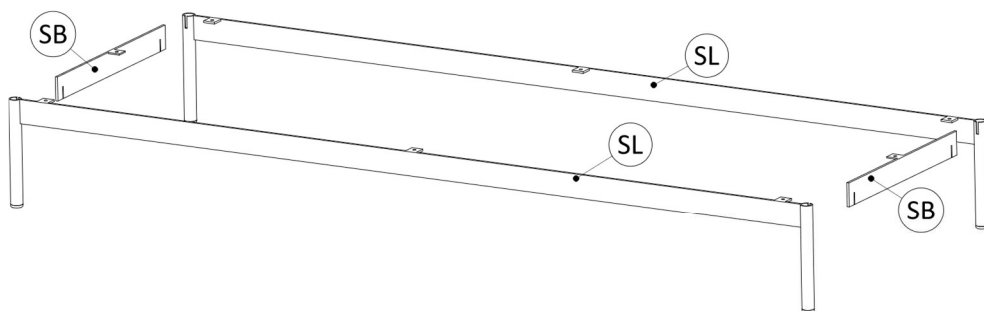
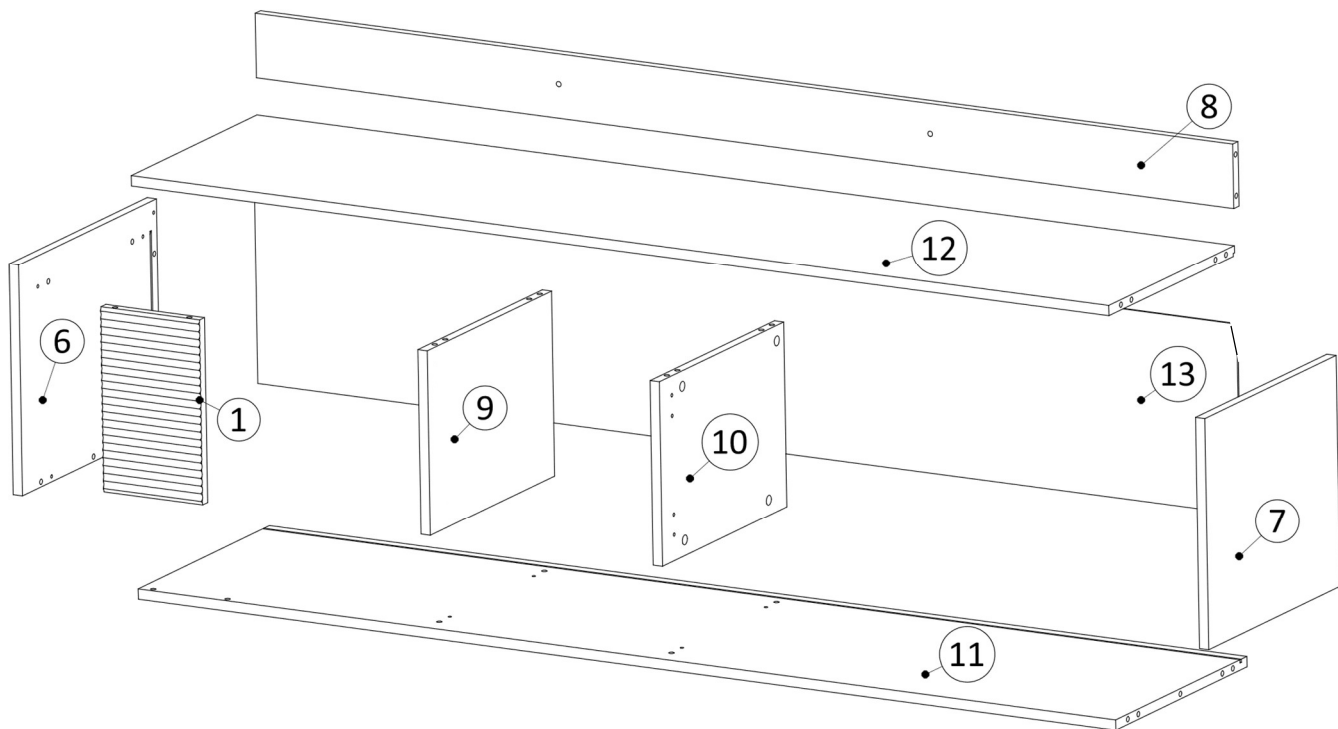

No.	T(mm)	L(mm)	W(mm)	pcs.
1	18	288	170	1
2	16	397	356	1
3	16	397	356	1
4	16	397	356	1
5	16	397	356	1
6	16	420	360	1
7	16	400	360	1
8	16	1684	100	1
9	16	379	288	1
10	16	379	288	1
11	16	1684	400	1
12	16	1684	383	1
13	3	1692	296	1

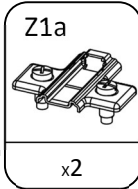
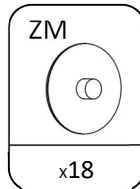
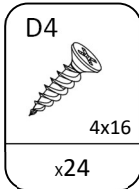
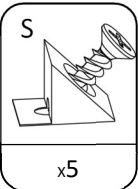
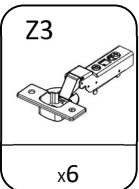
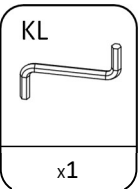
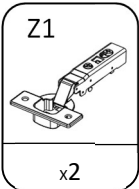
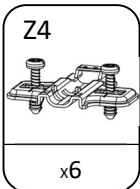
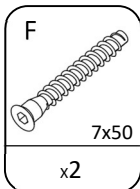
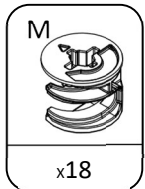
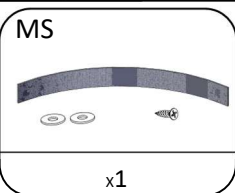
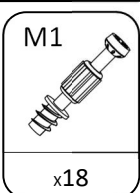
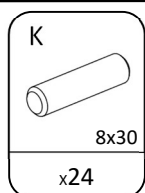

1

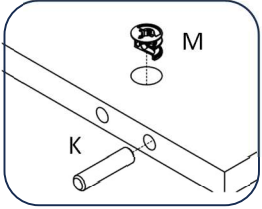
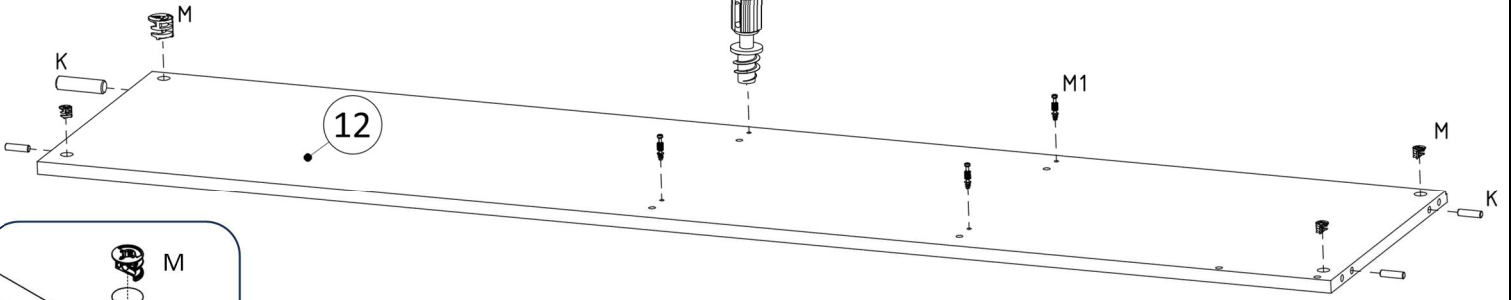
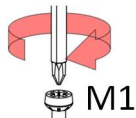
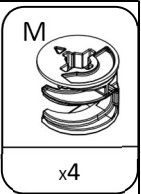
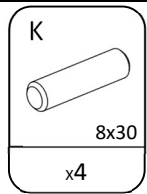
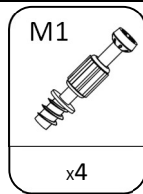
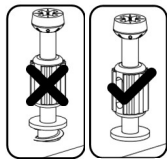

2

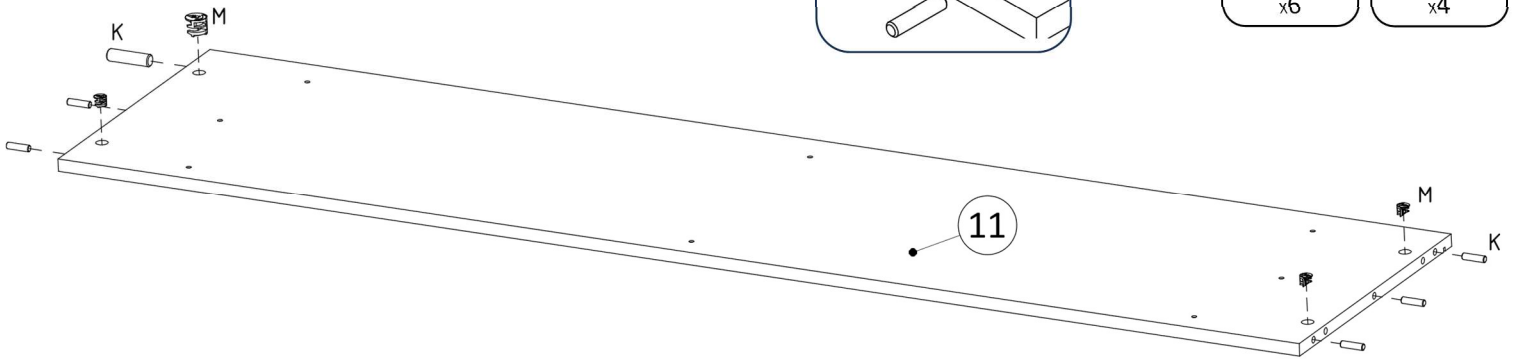
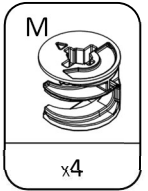
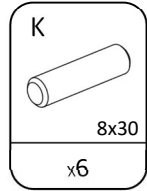
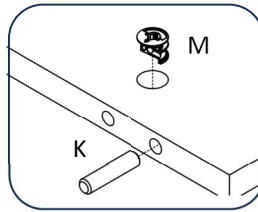

3

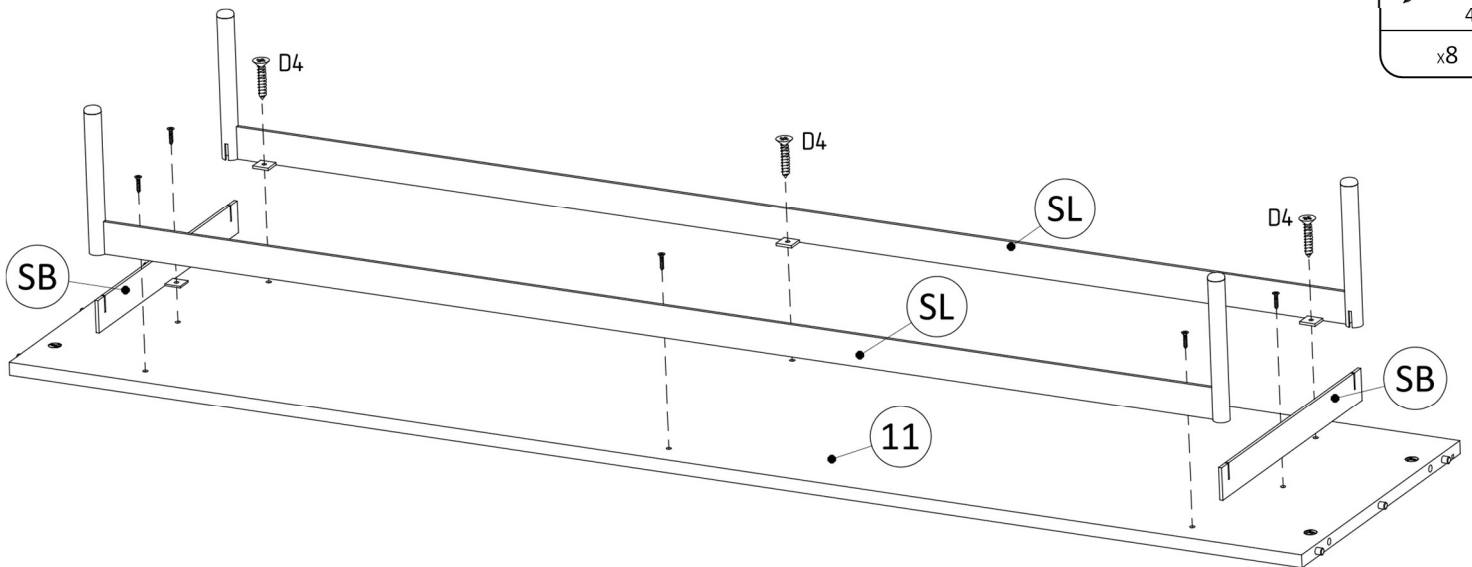
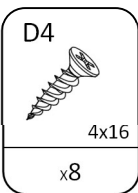

4

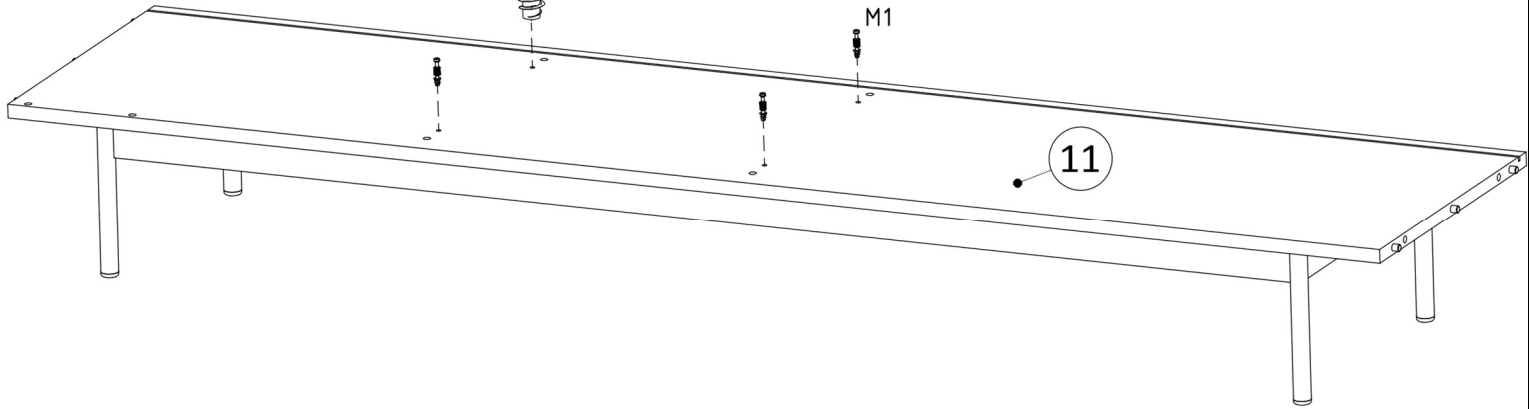
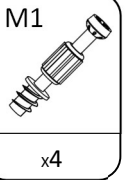
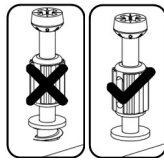
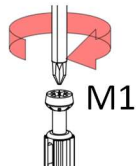

5

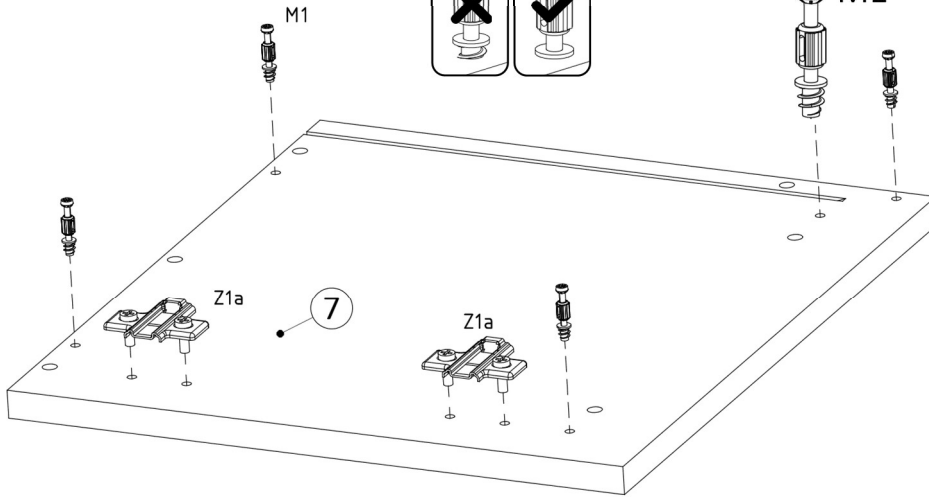
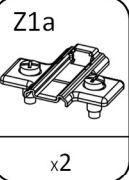
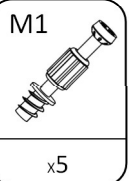
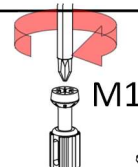
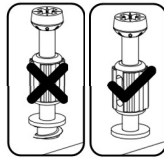

6

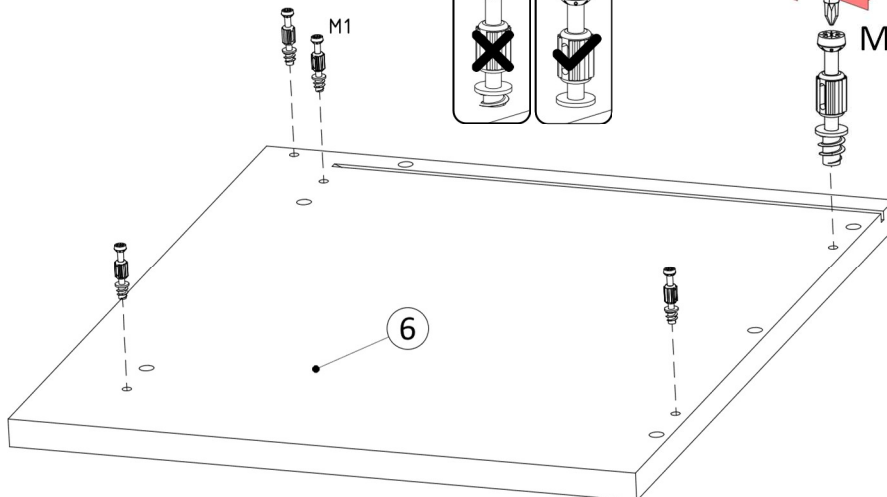
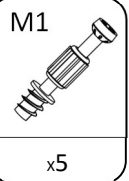
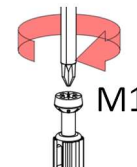
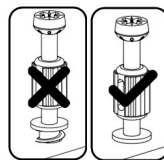

7

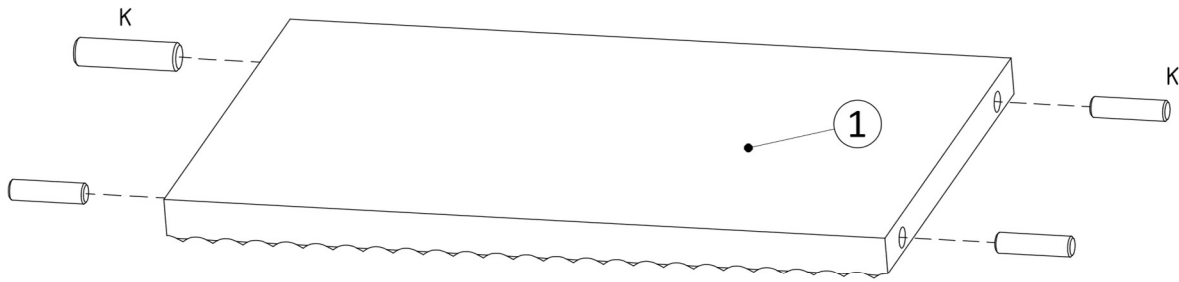

K	
	8x30
	x4

8

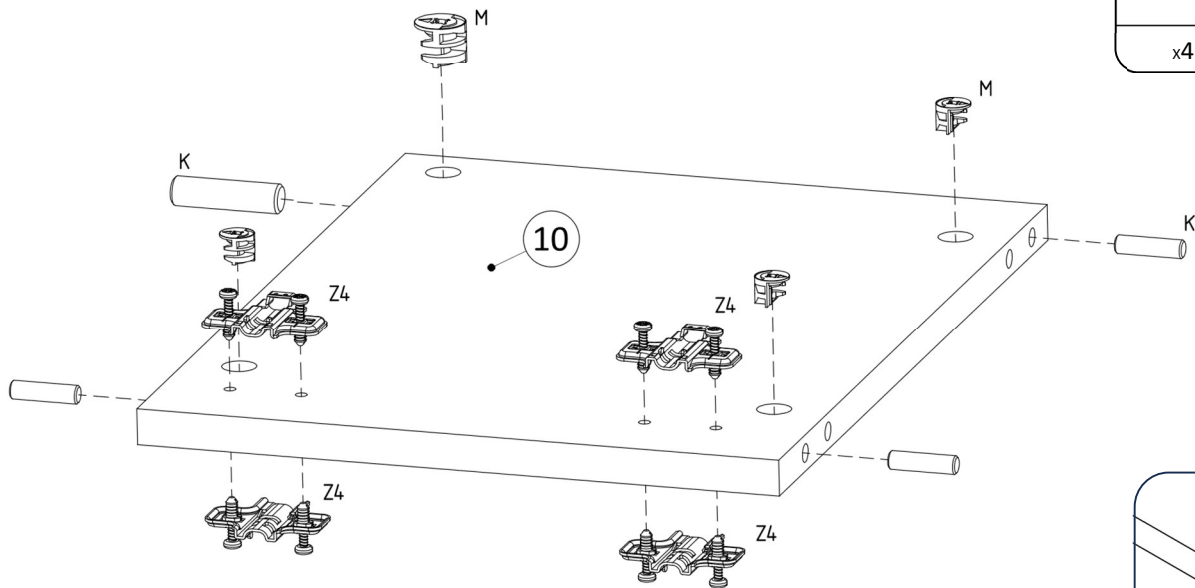

K	
	8x30
	x4

M	
	x4

Z4	
	x4

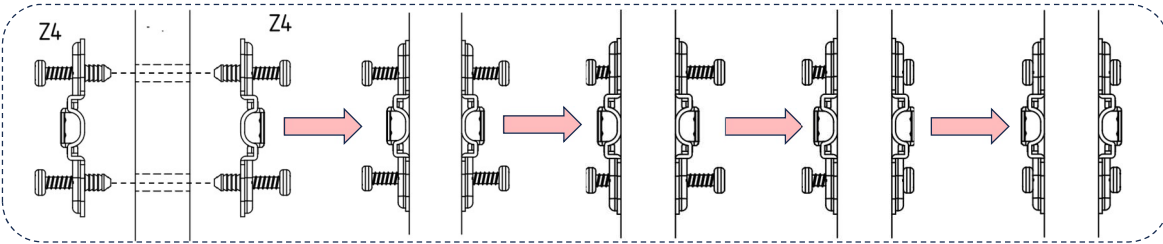
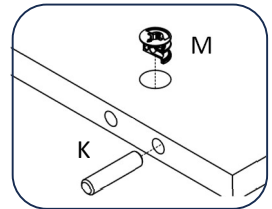

9

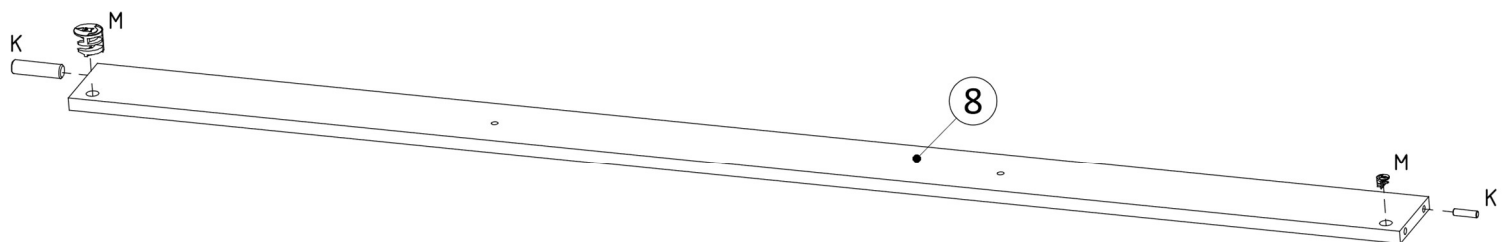

M	
	x2

K	
	8x30
	x2

10

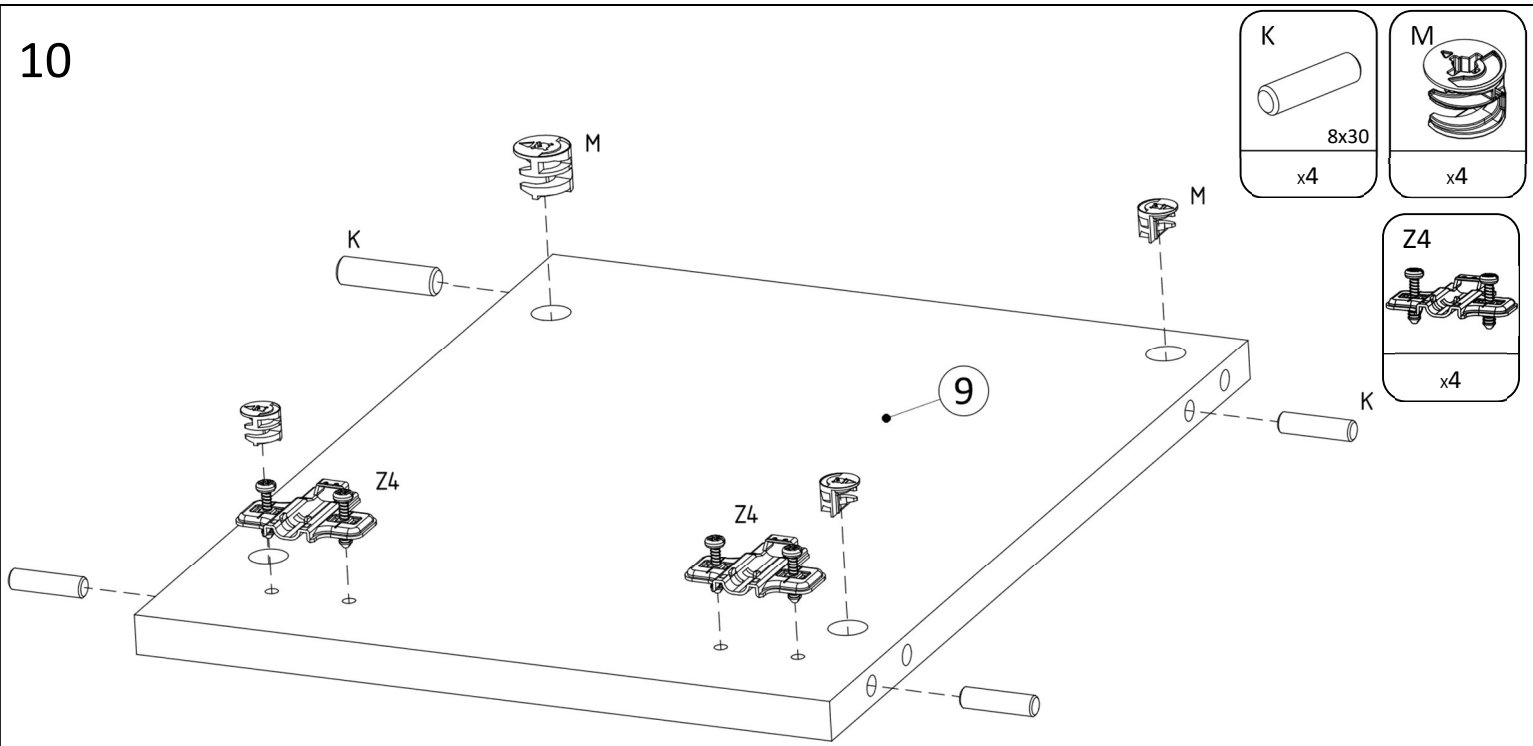

11

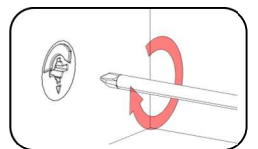
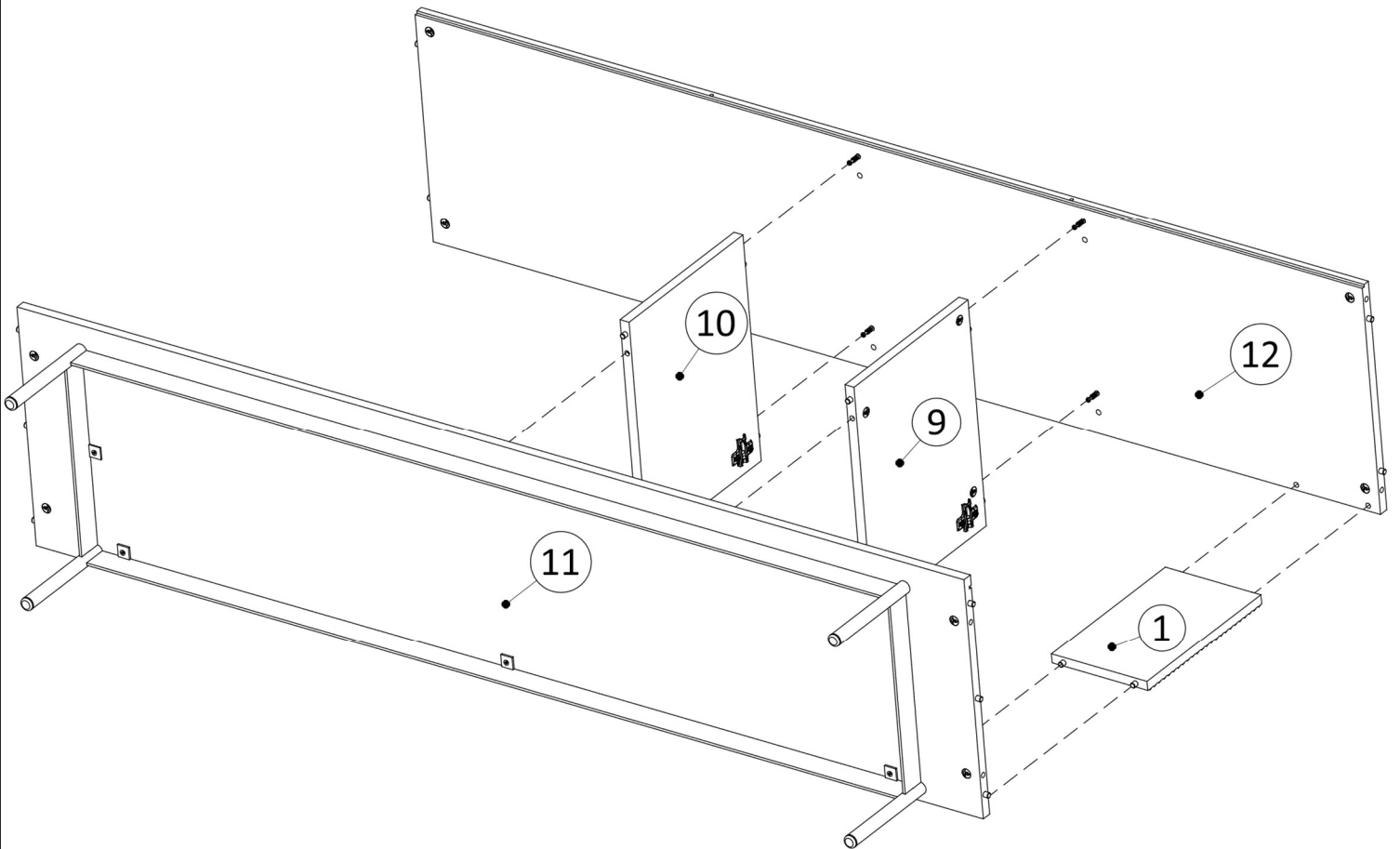

12

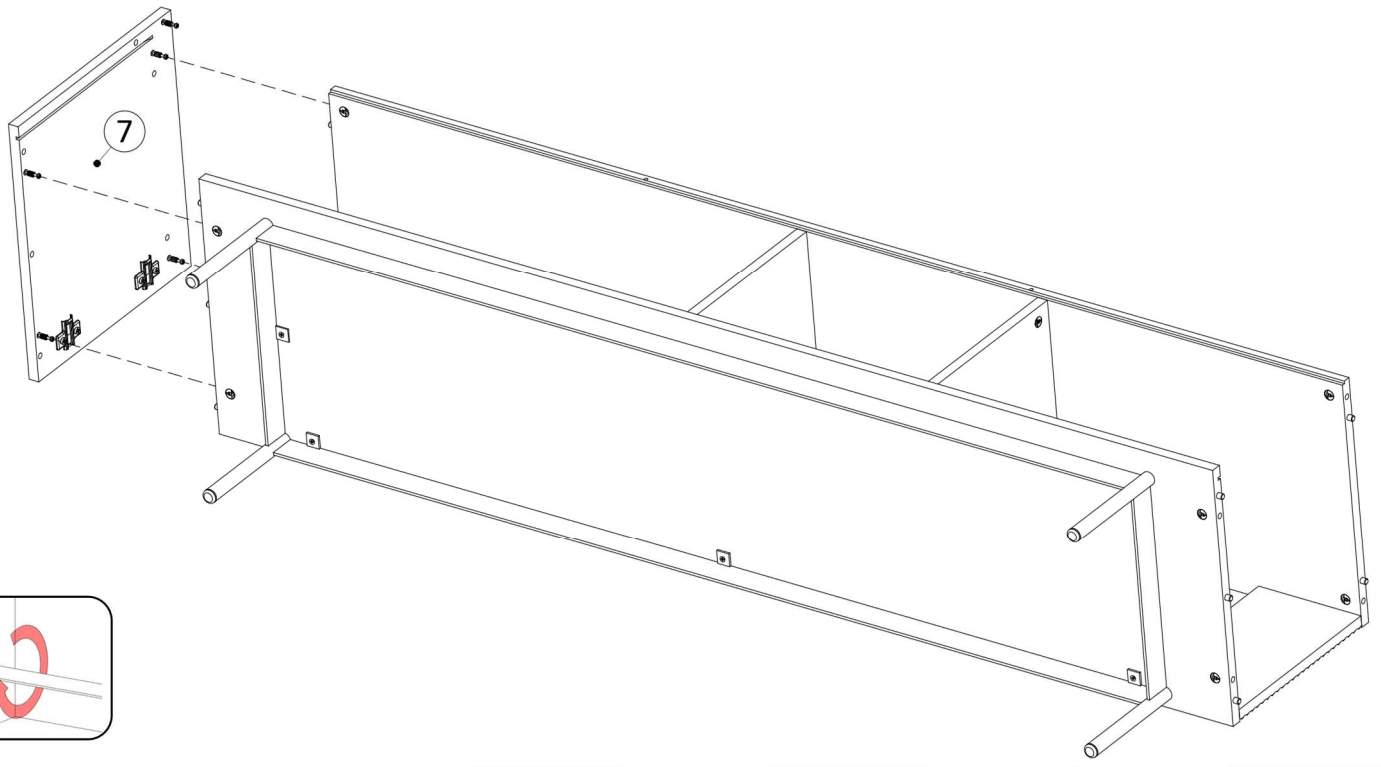

13

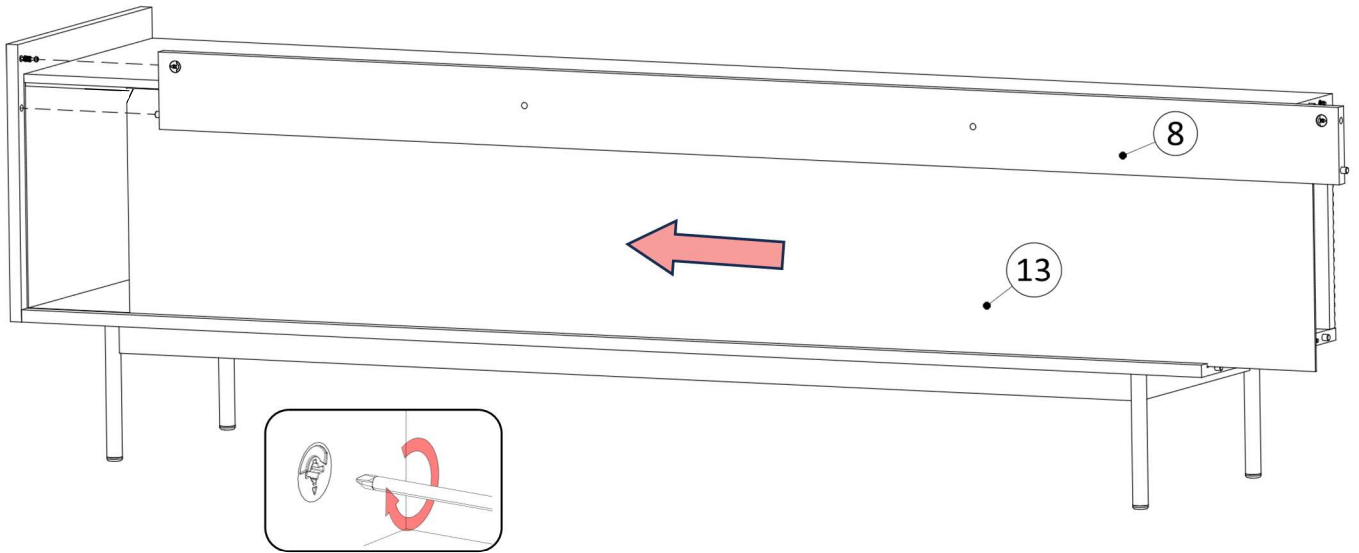

14

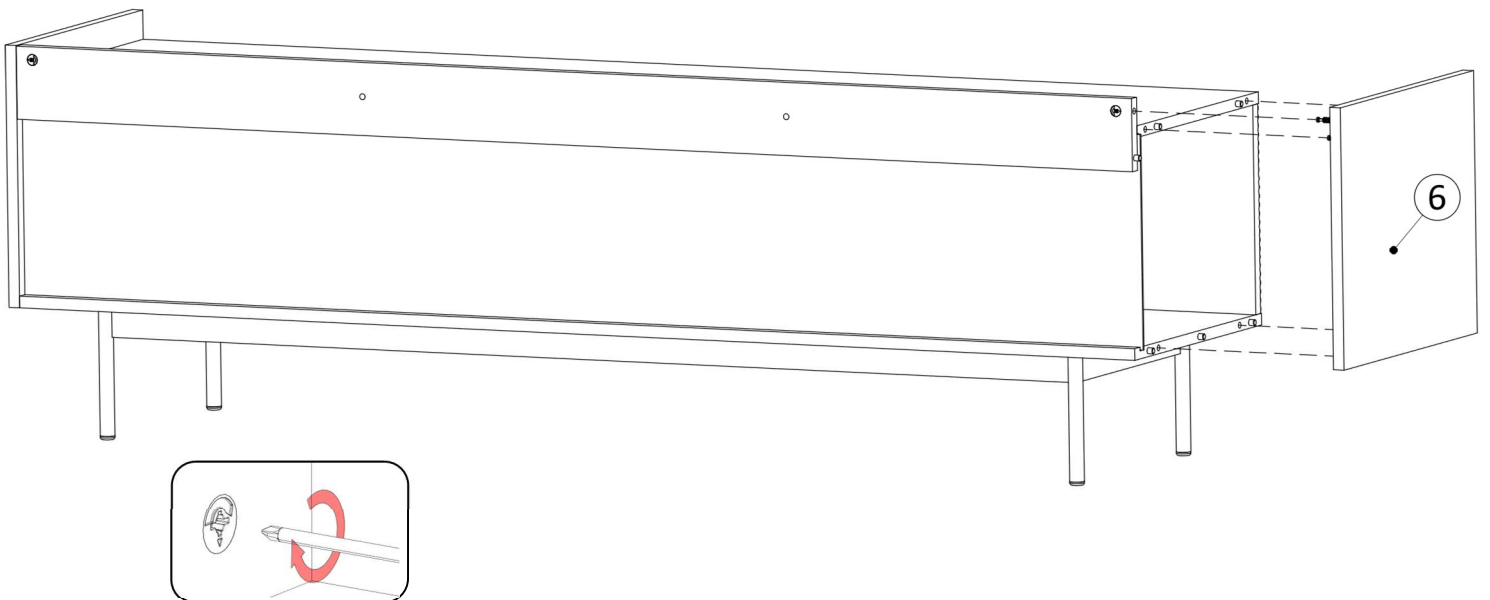

15

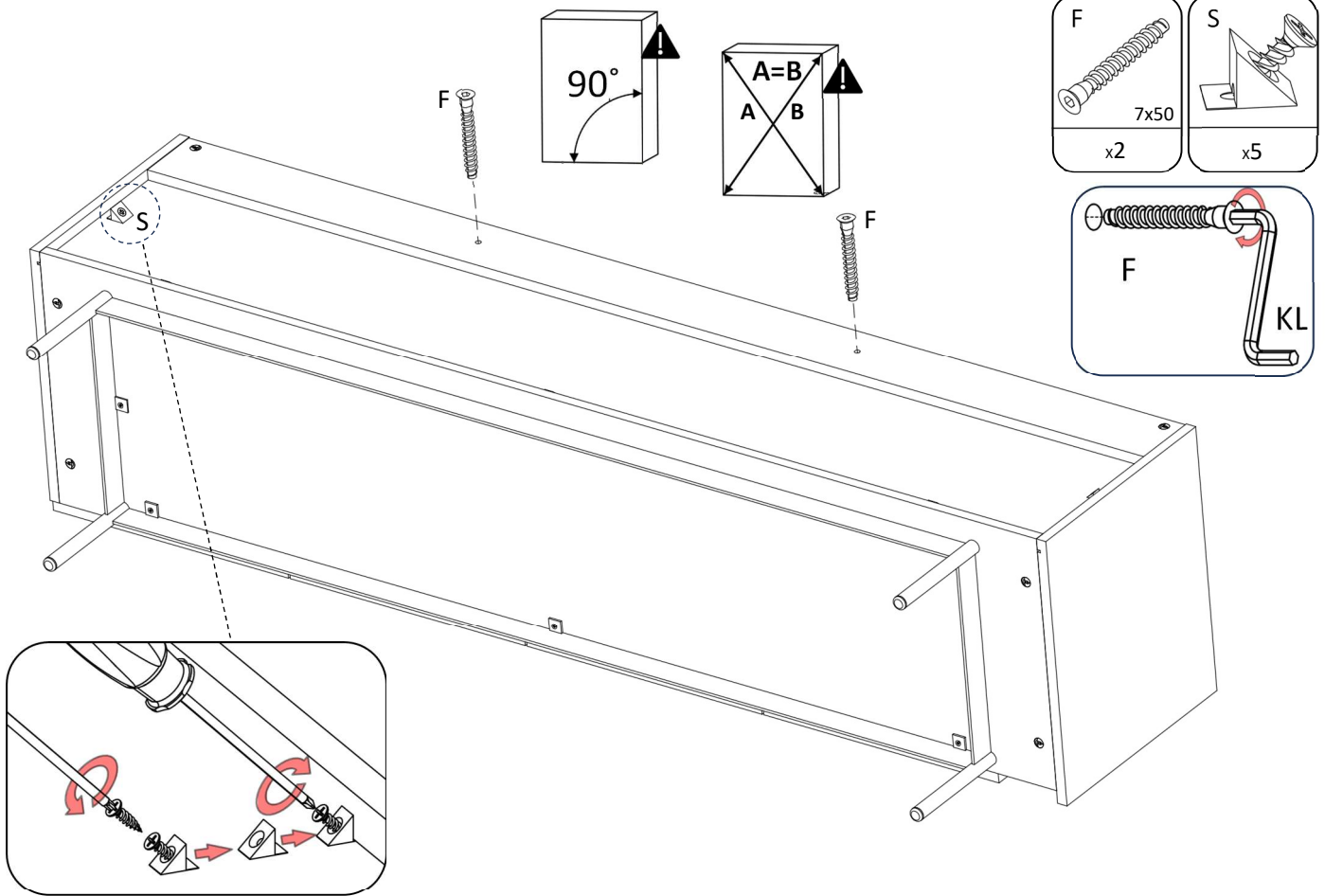

16

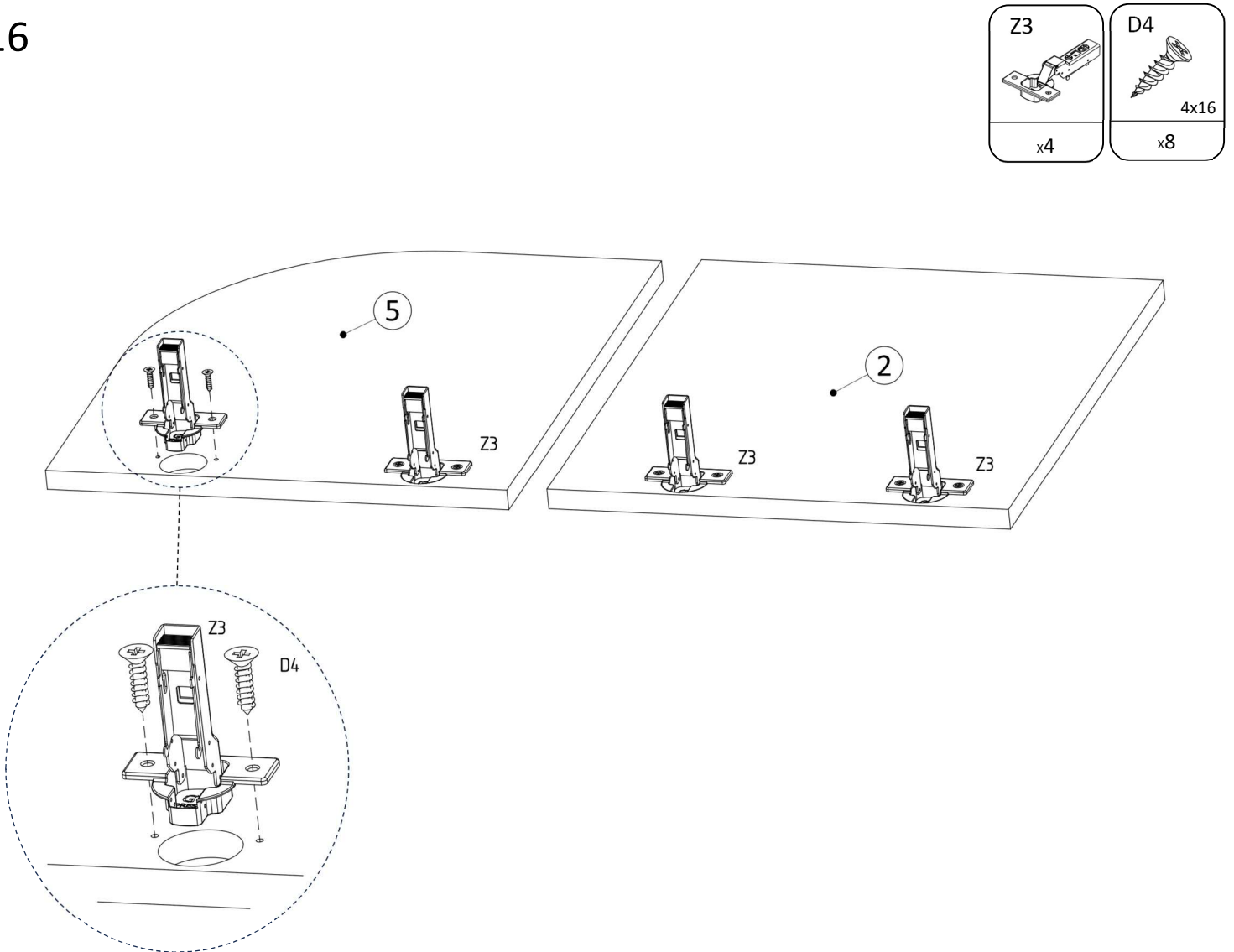

17

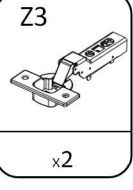
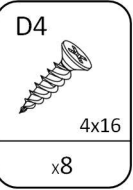
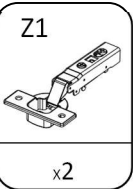
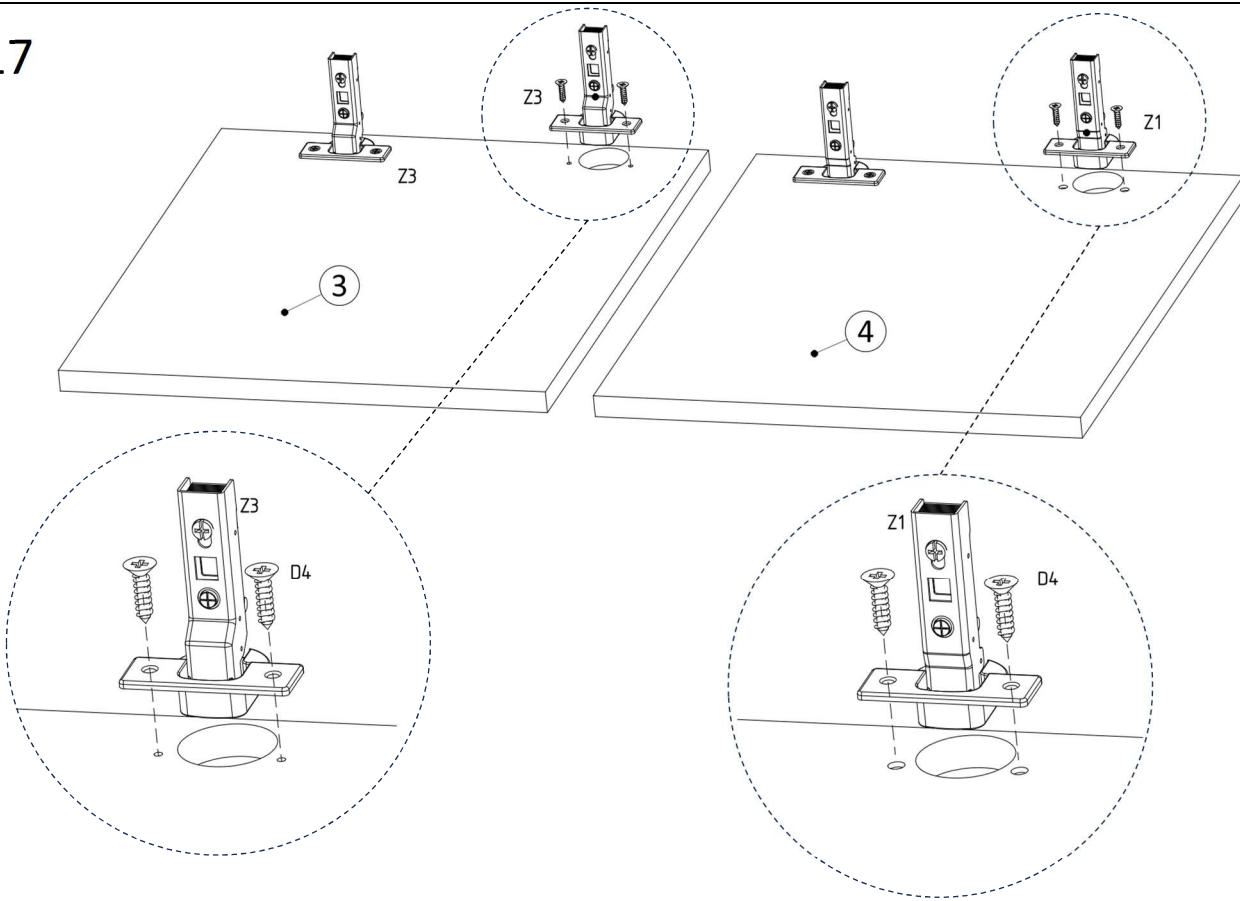

18

