

CARMEN

R-8

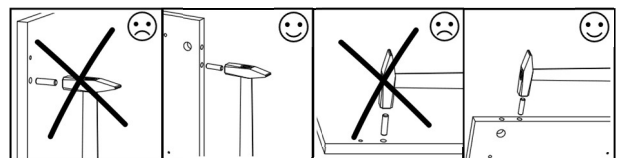

No	T(mm)	L(mm)	W(mm)	pcs.
1	648	170	18	1
2	397	237	16	3
3	716	397	16	1
4	490	354	16	1
5	320	140	16	3
6	720	420	16	1
7	350	140	16	3
8	720	400	16	1
9	884	200	16	1
10	378	100	16	1
11	884	100	16	1
12	648	379	16	1
13	884	400	16	1
14	884	383	16	1
15	350	140	16	3
16	892	327	3	1
17	333	346	3	3
18	892	327	3	1

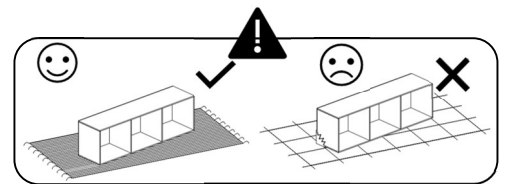
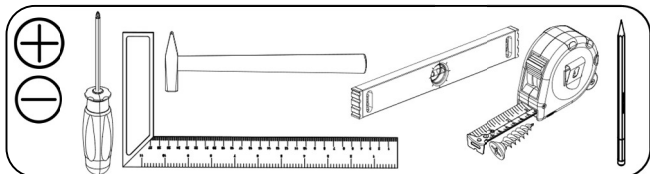
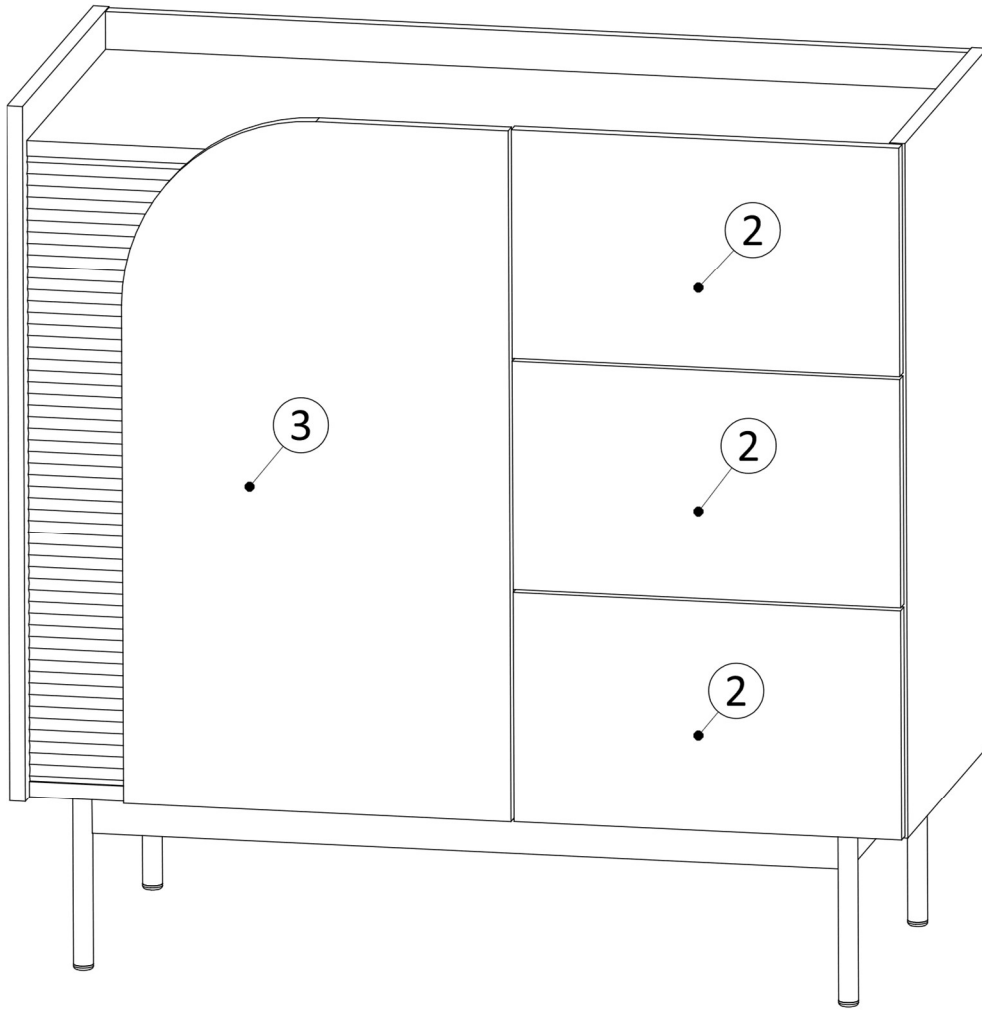
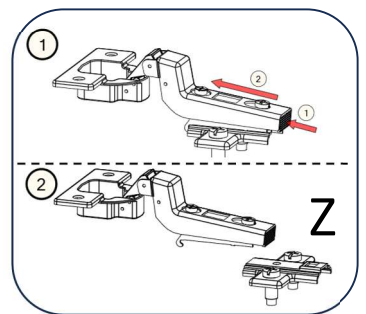
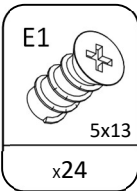
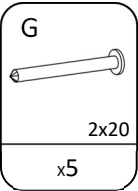
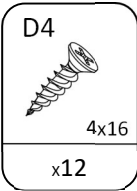
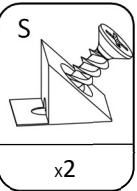
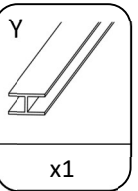
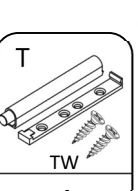
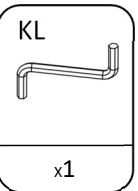
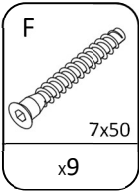
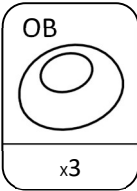
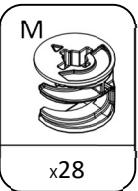
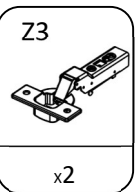
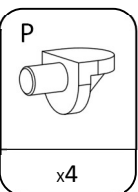
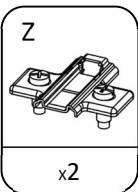
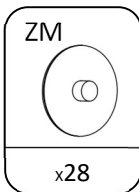
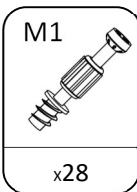
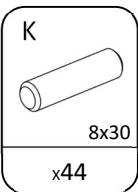
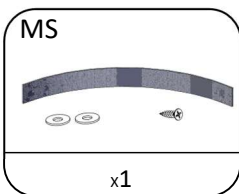
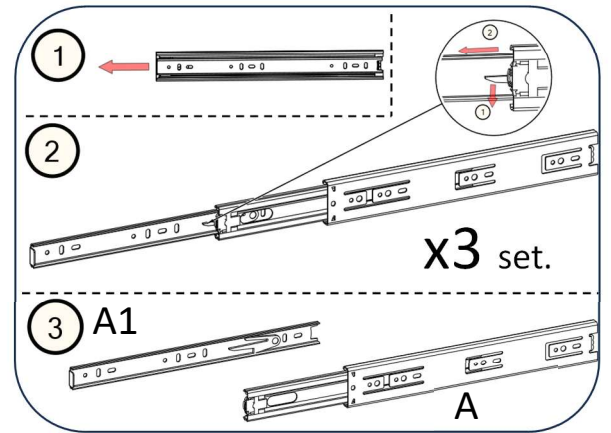
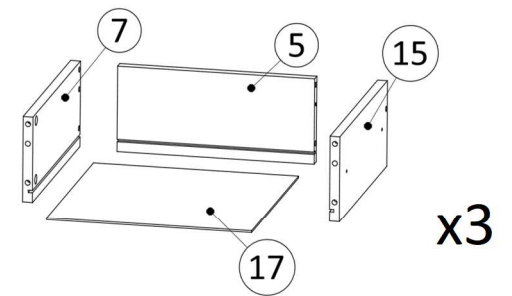
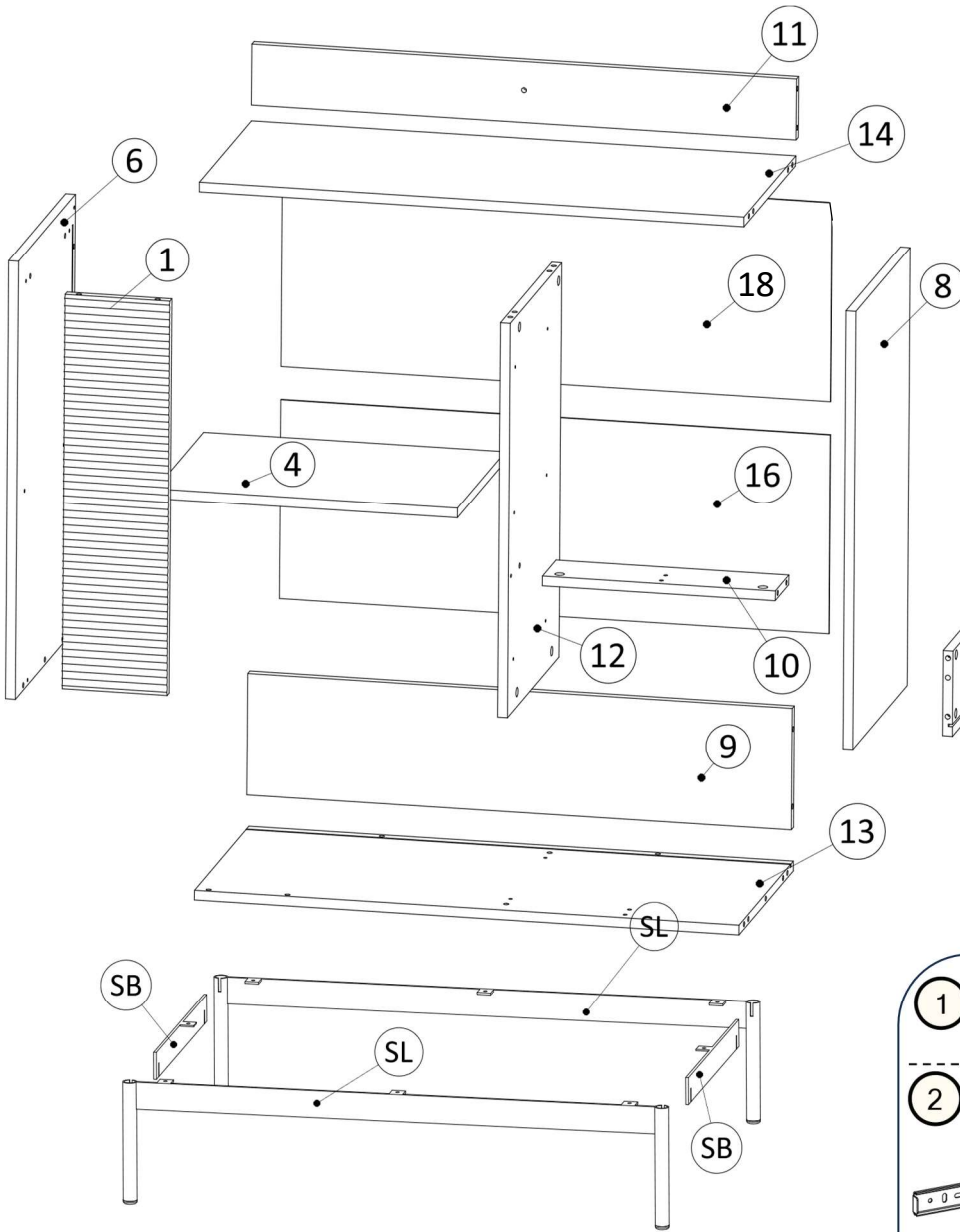

1

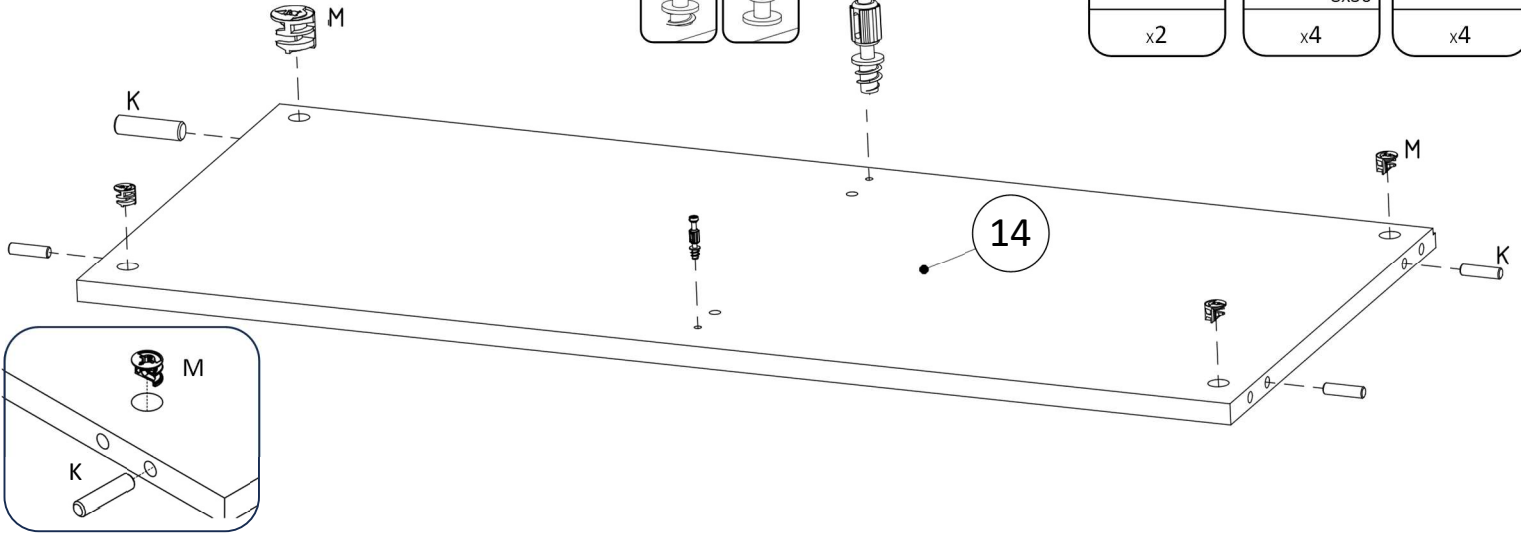
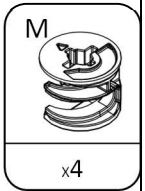
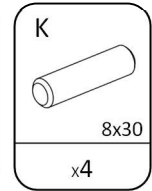
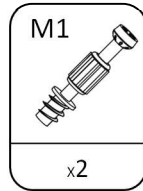
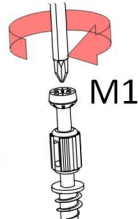
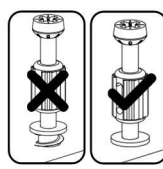

2

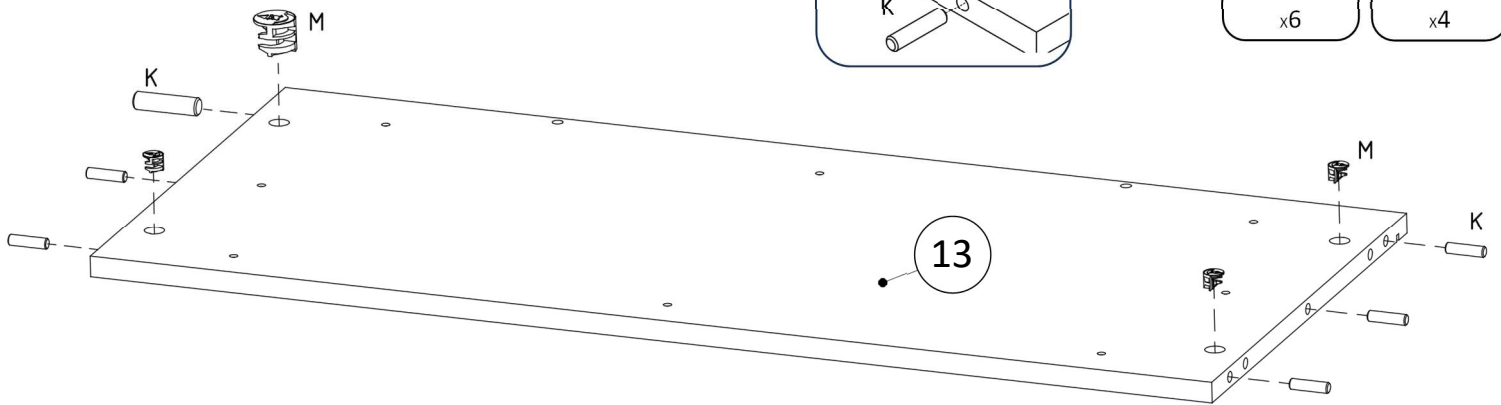
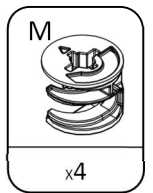
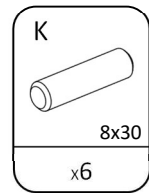
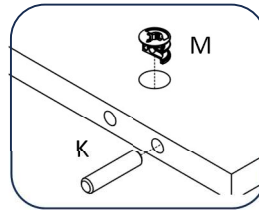

3

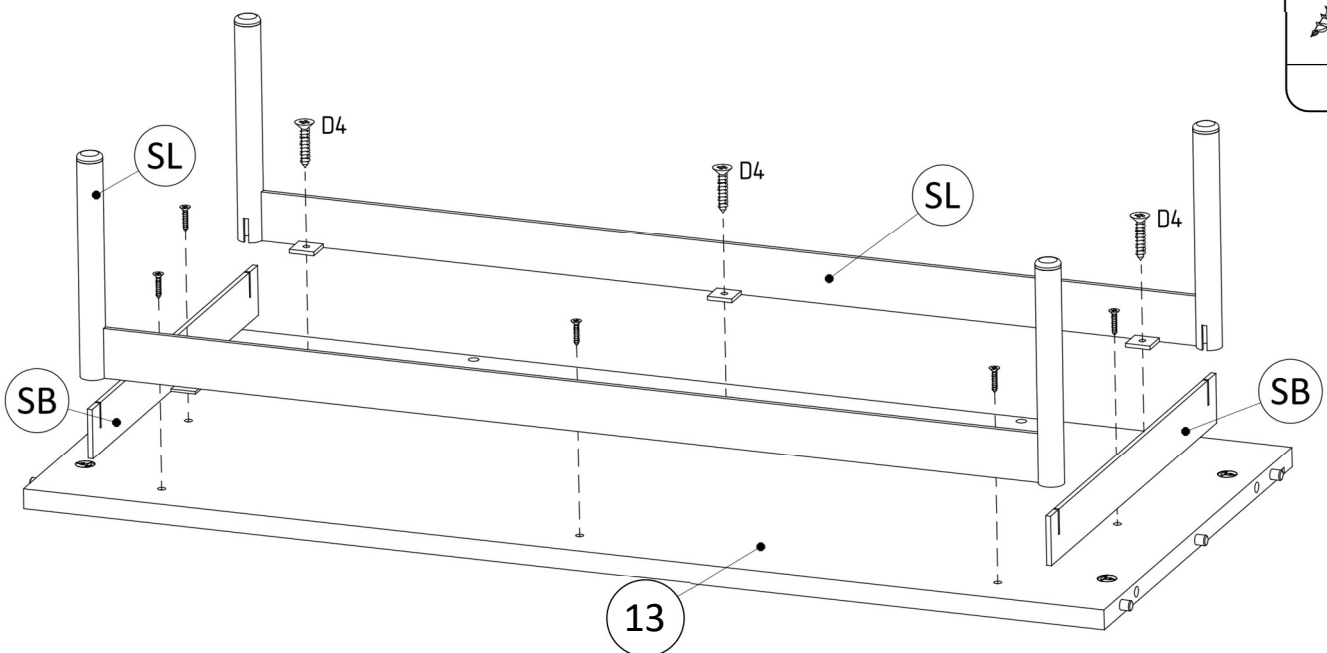
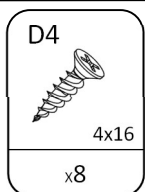

4

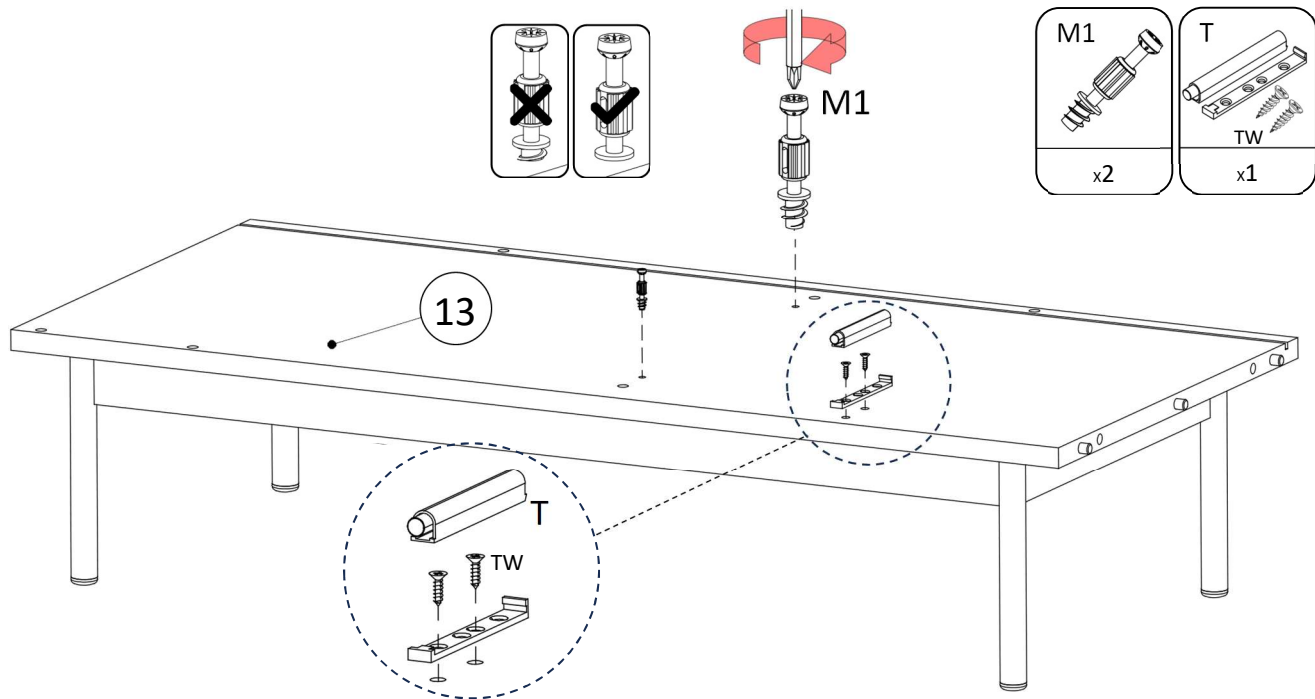

5

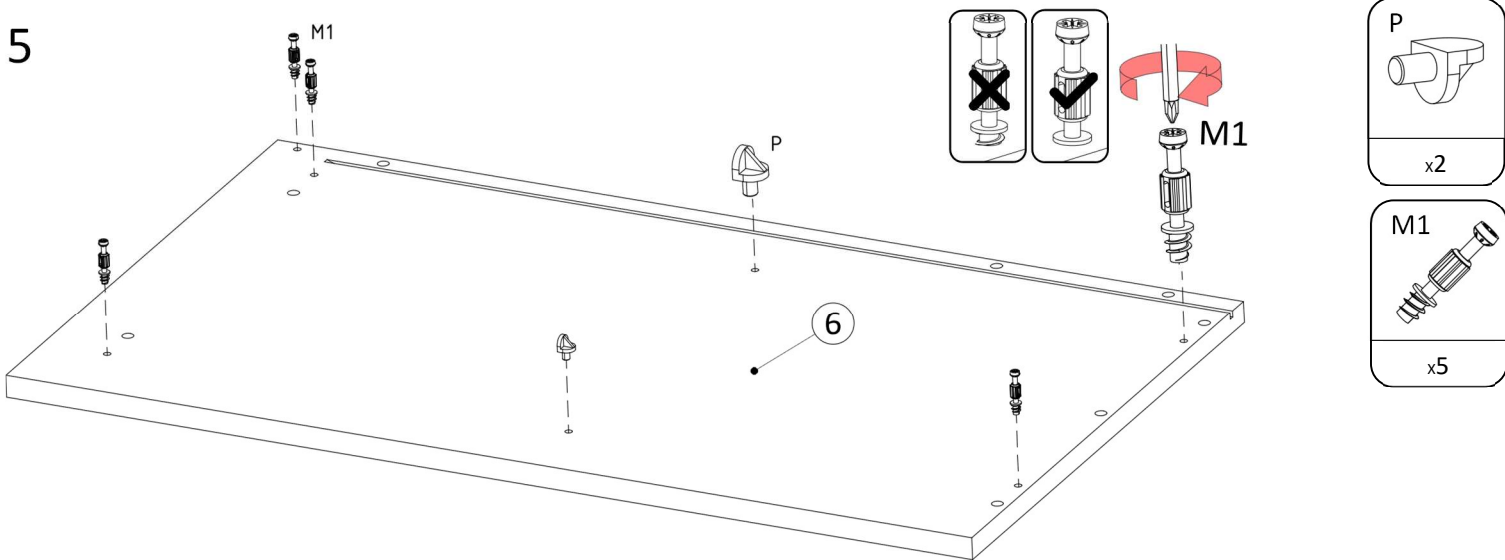

6

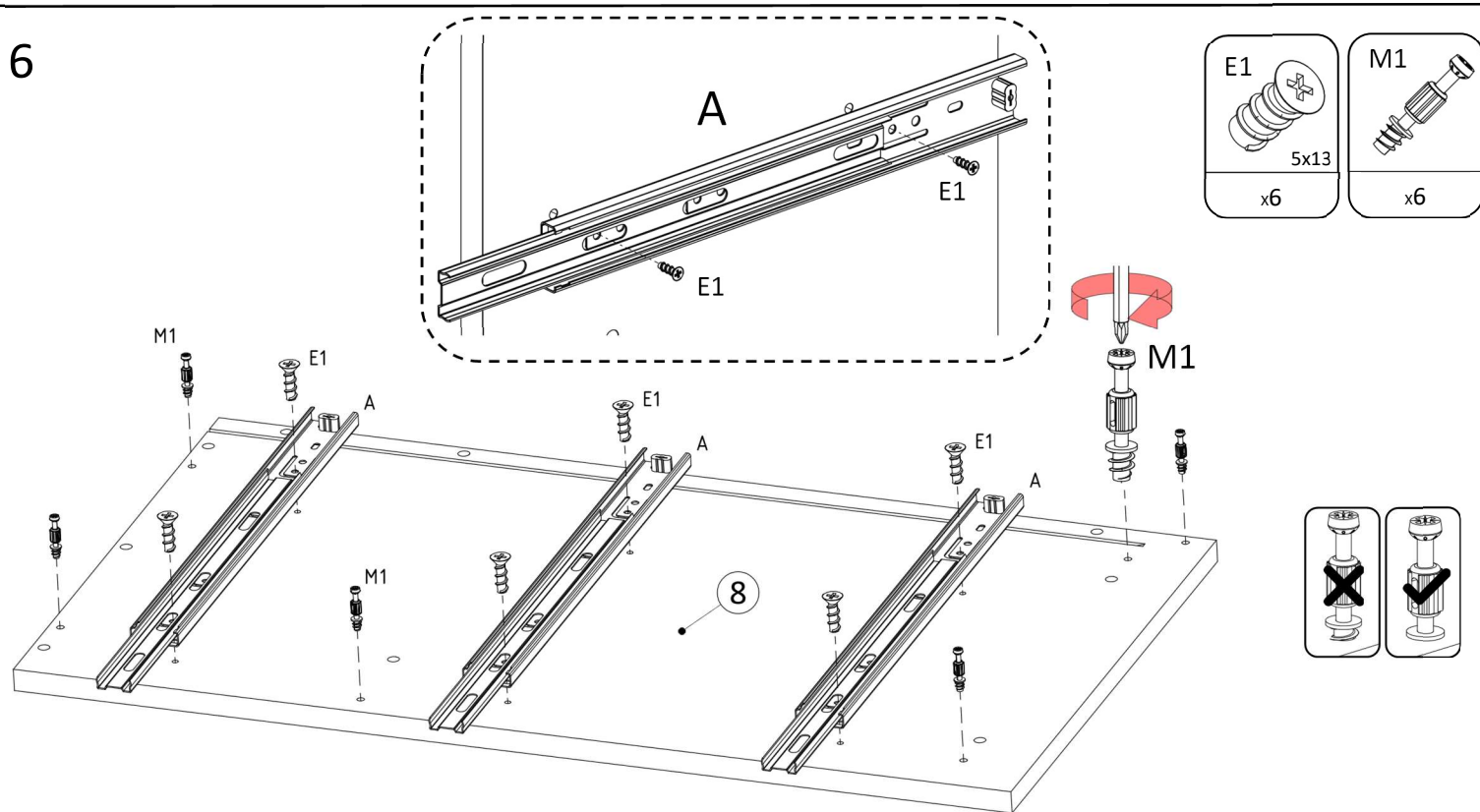

7

M1	K	M	E1
x1	8x30 x4	x4	5x13 x6

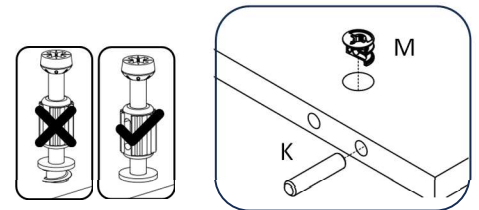
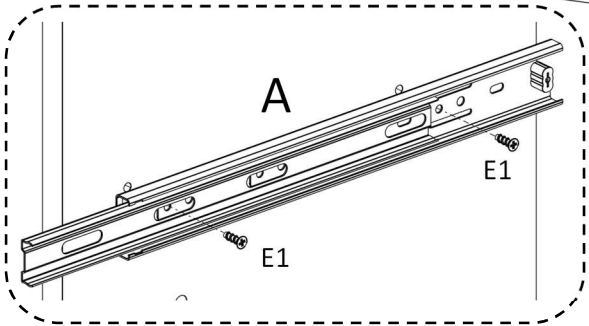
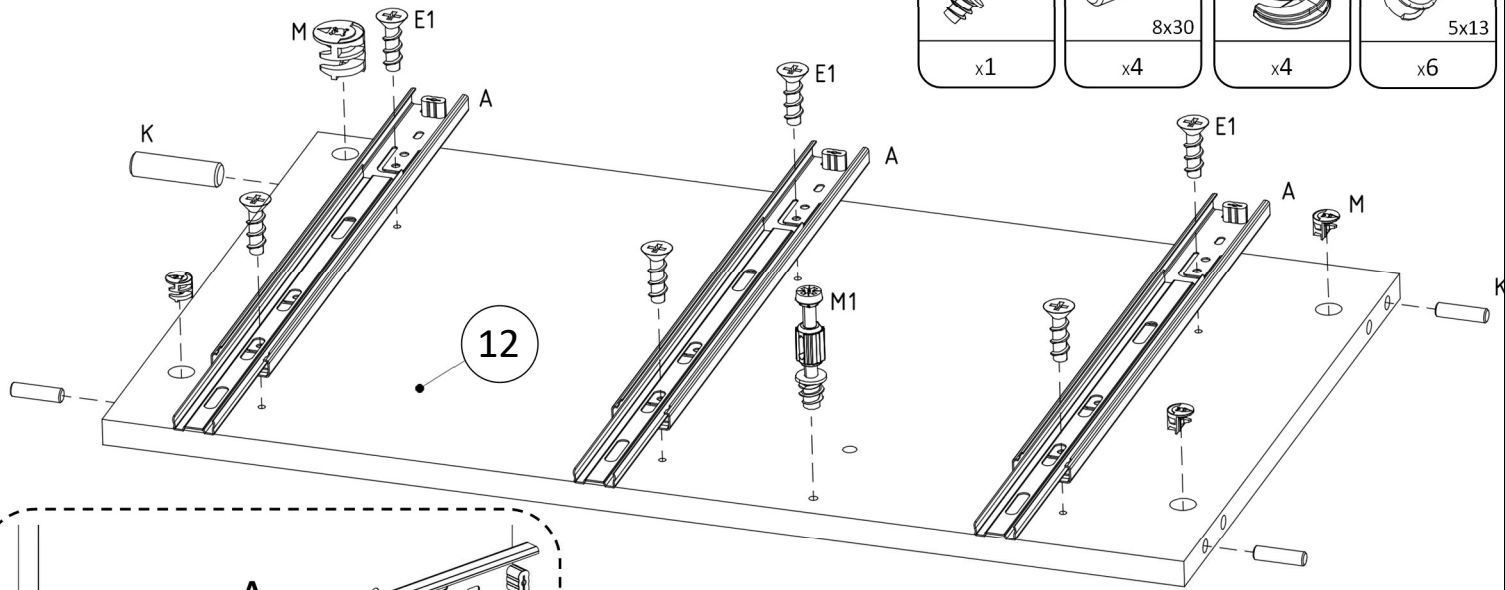

8

Z
x2

P
x2

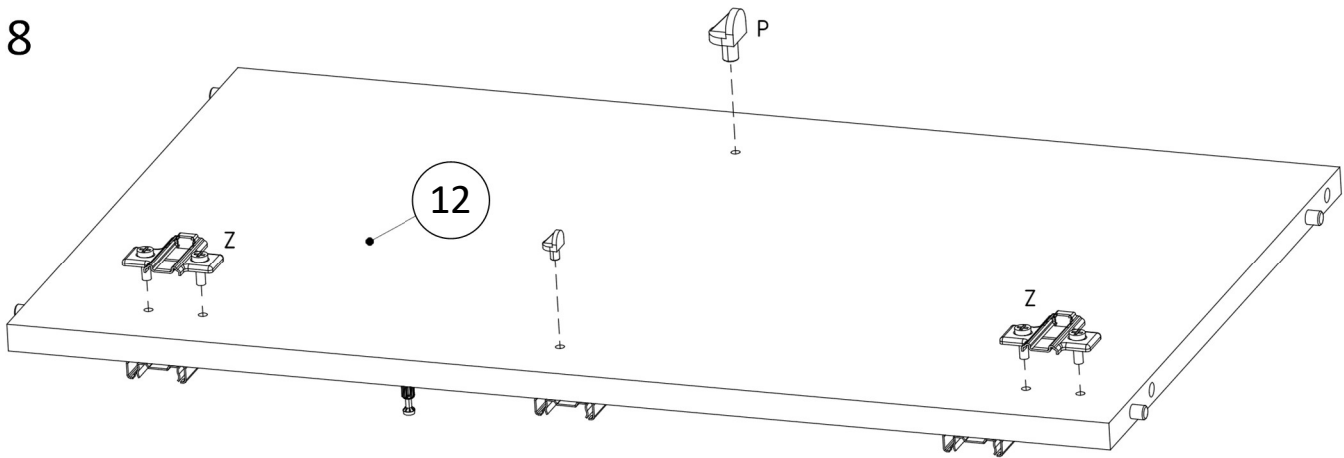

9

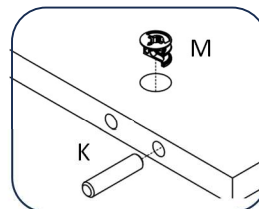

K
8x30 x6

M
x2

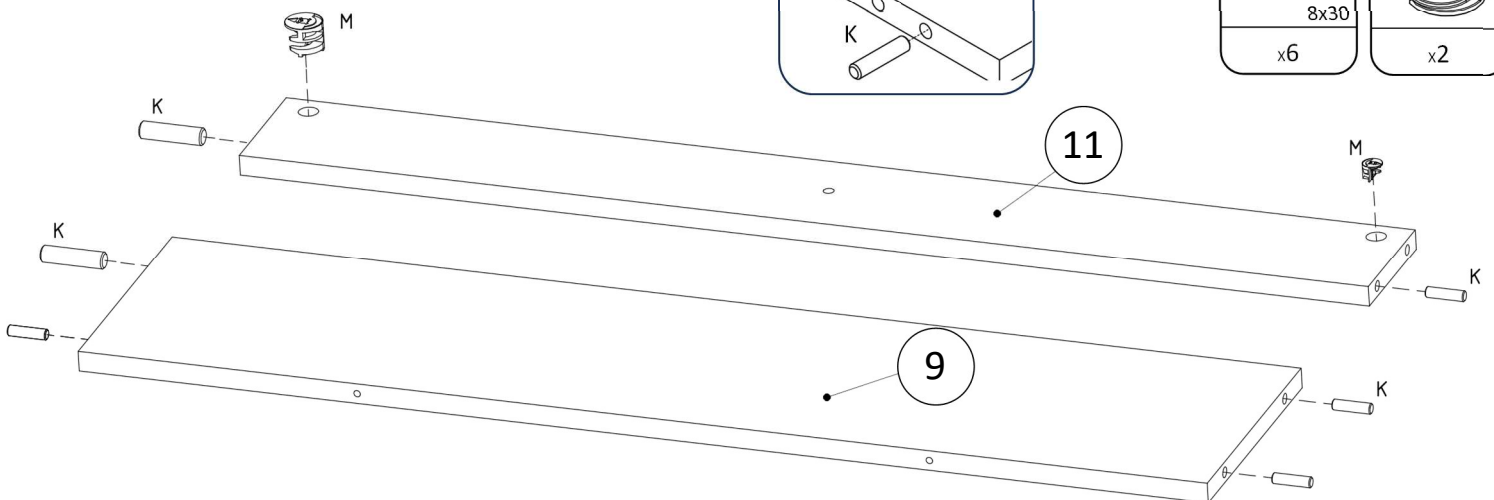

10

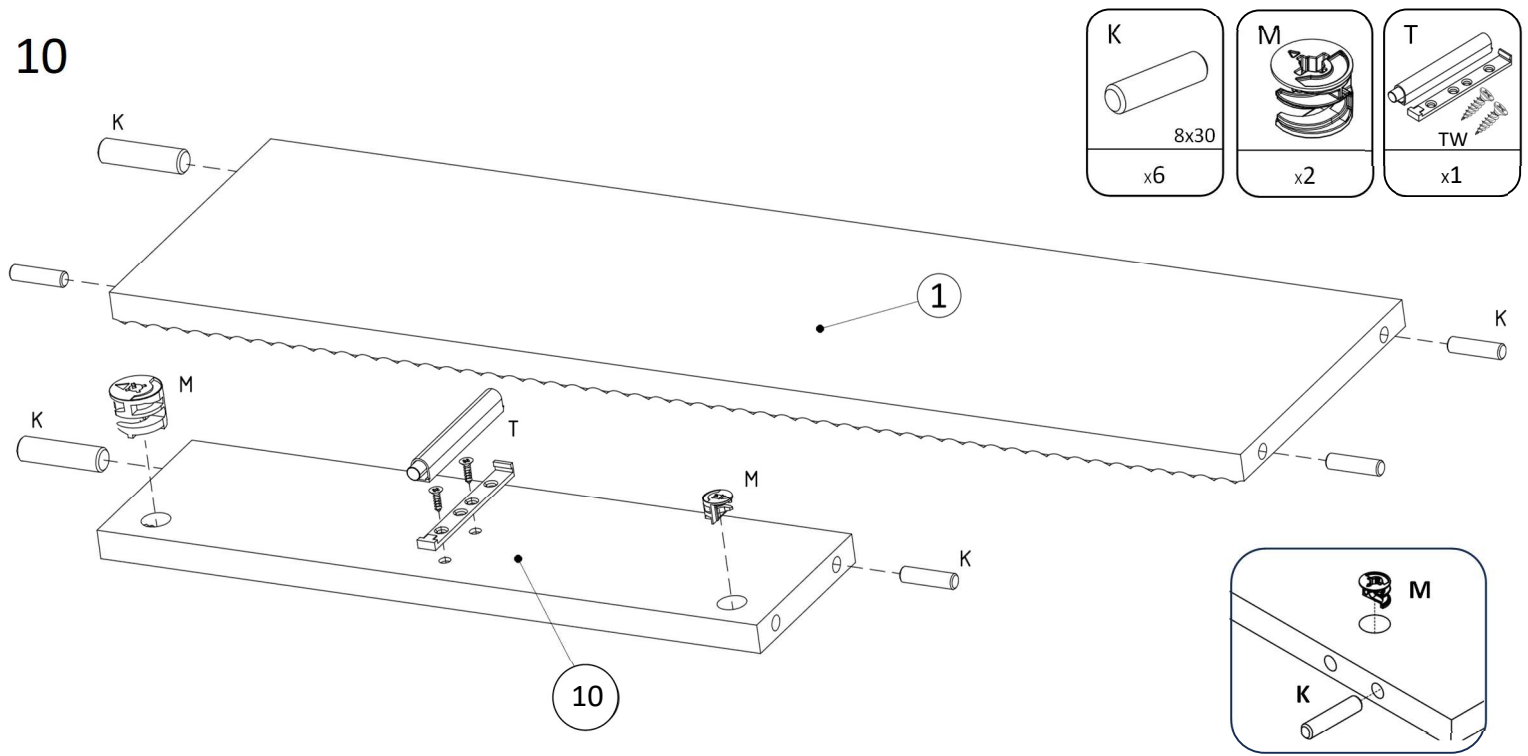

11

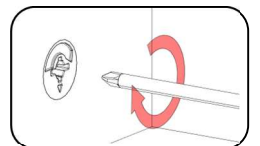
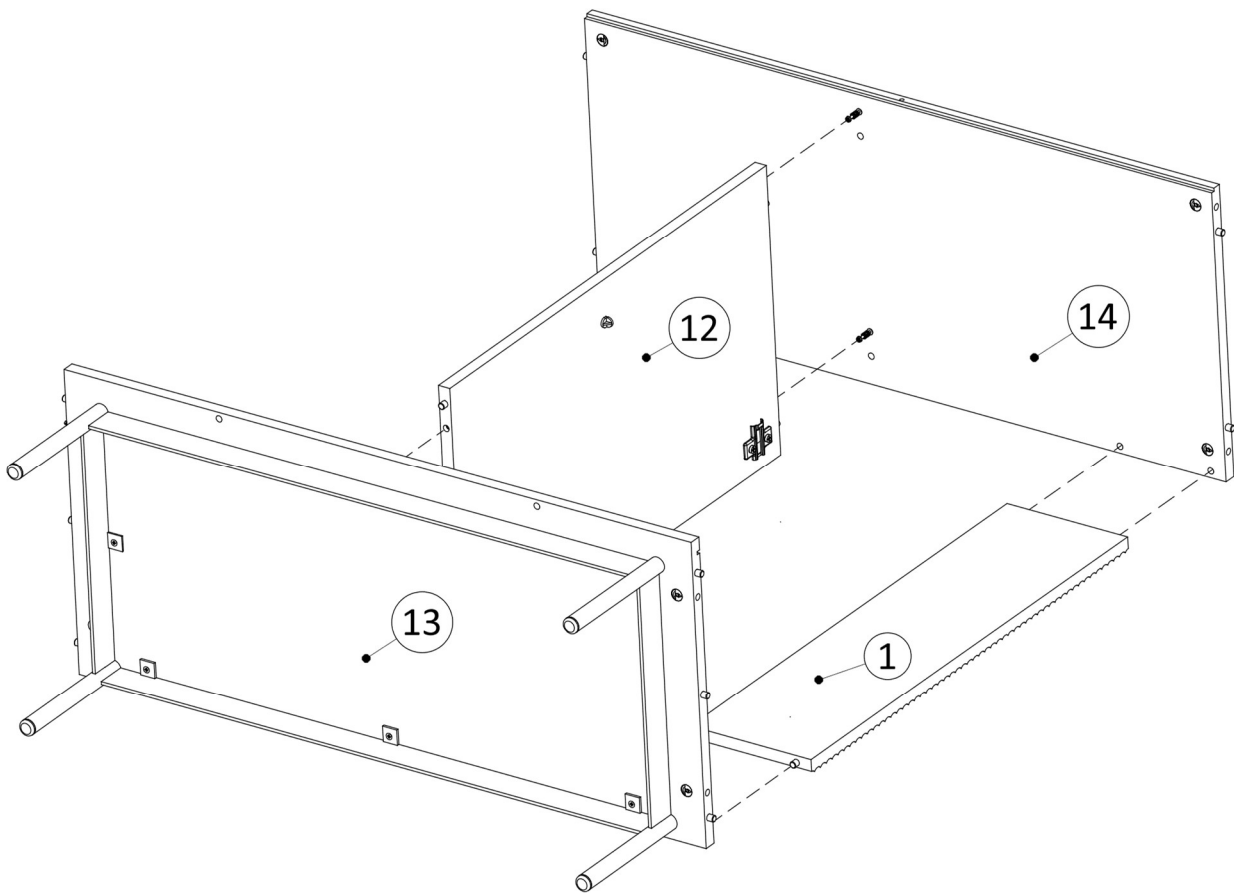

12

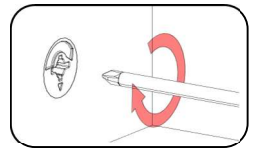
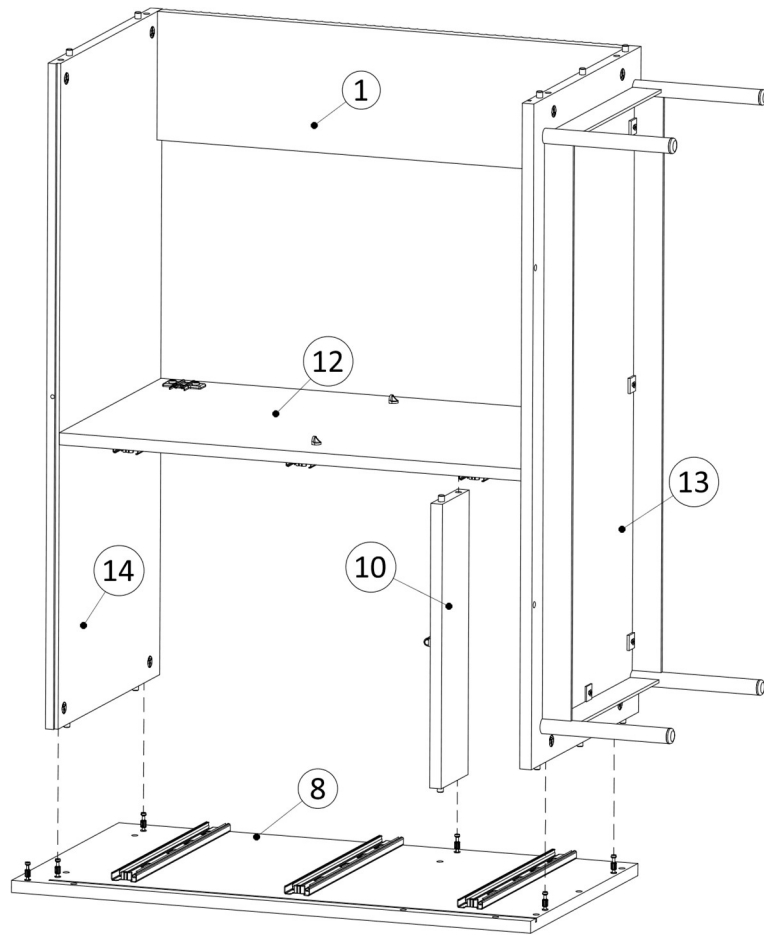

13

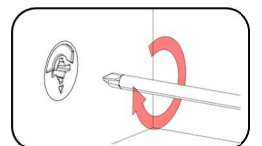
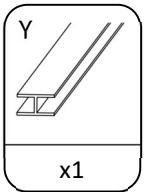
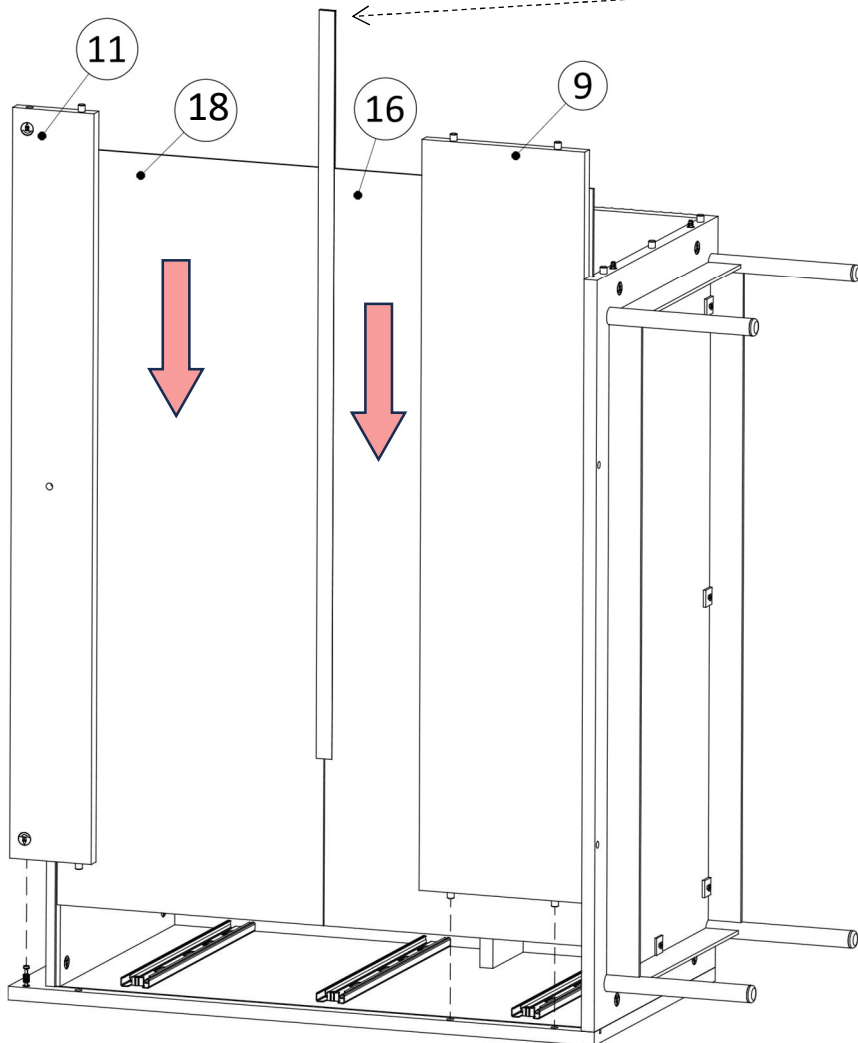

14

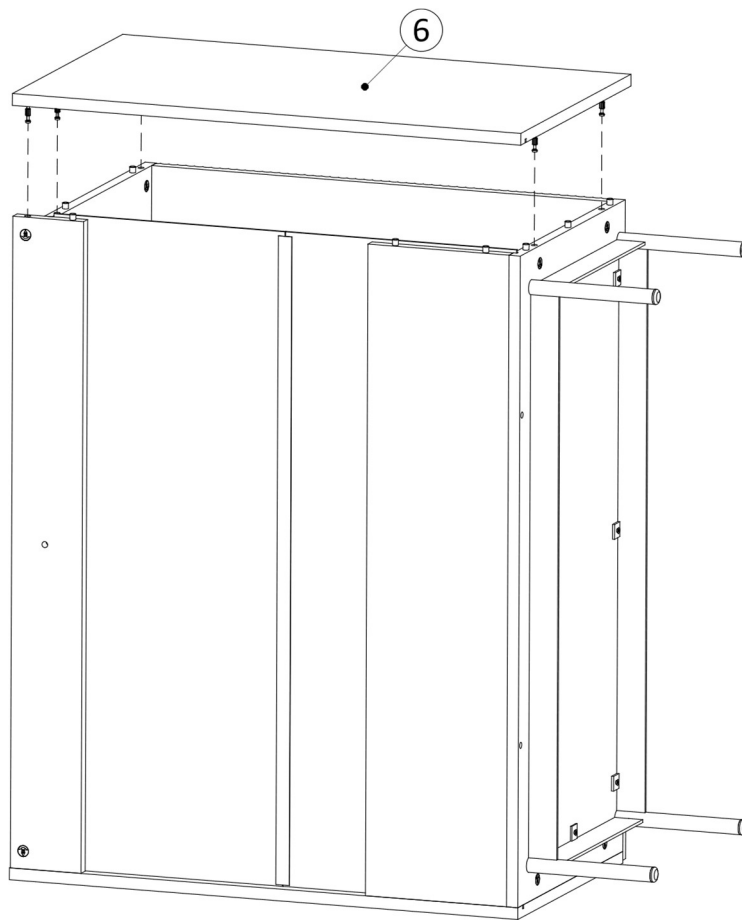

15

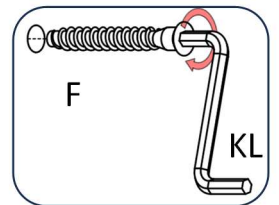
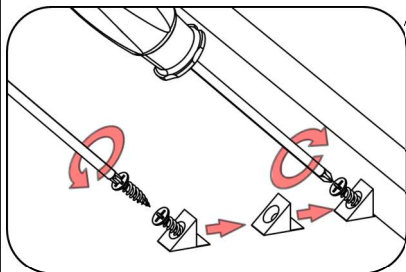
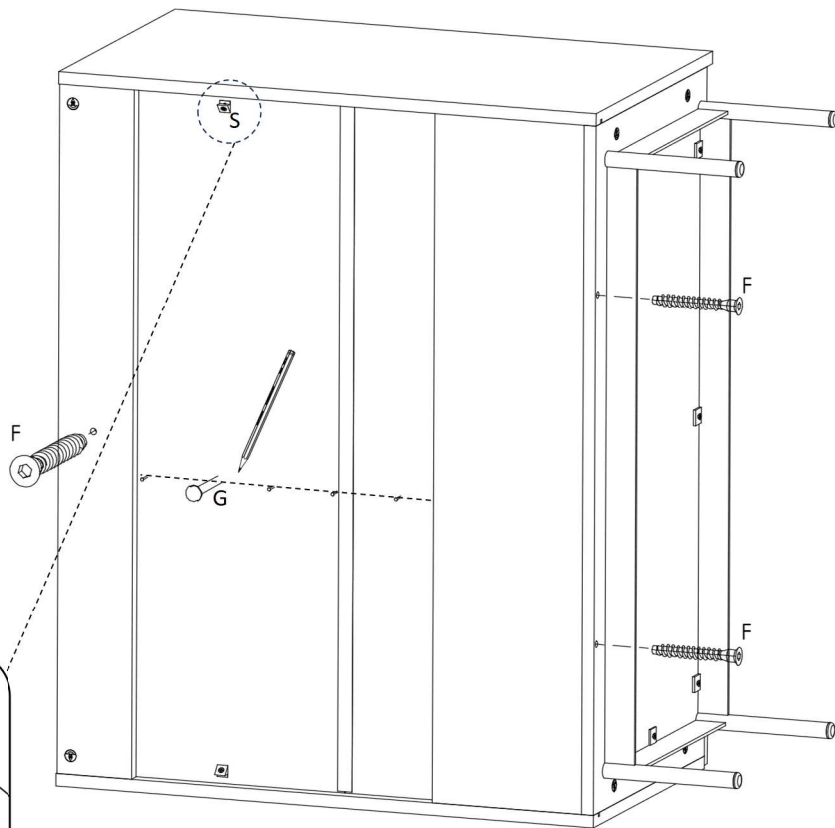
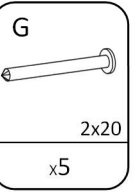
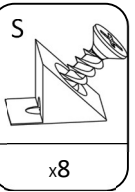
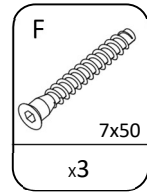
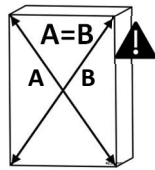
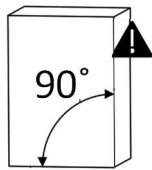

16

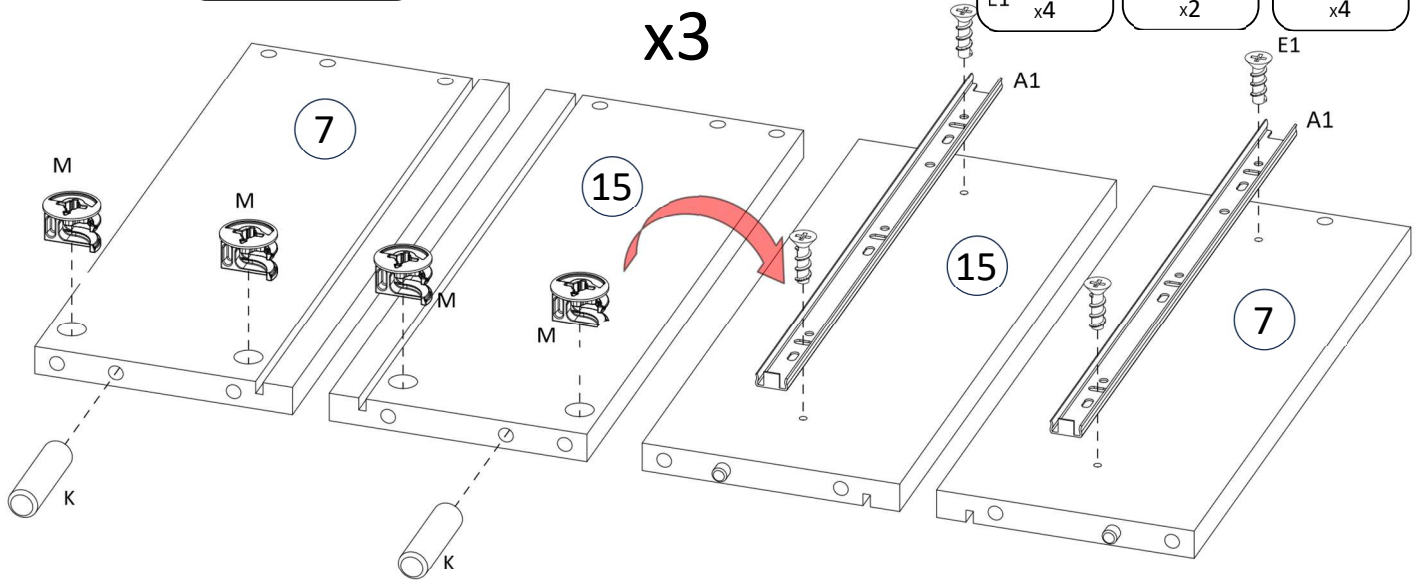
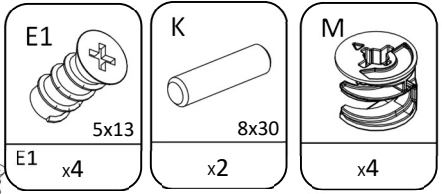
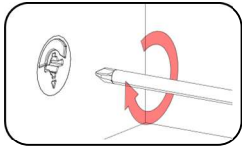

17

x3

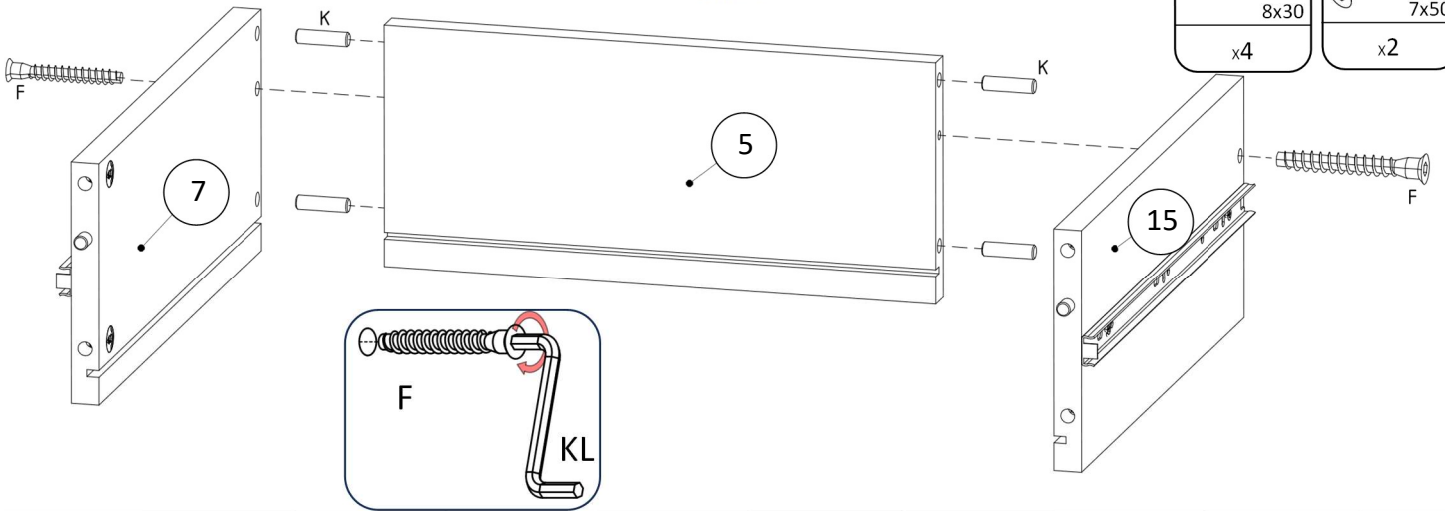
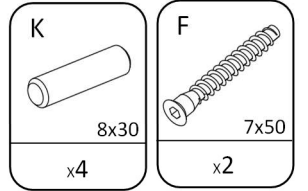

18

x3

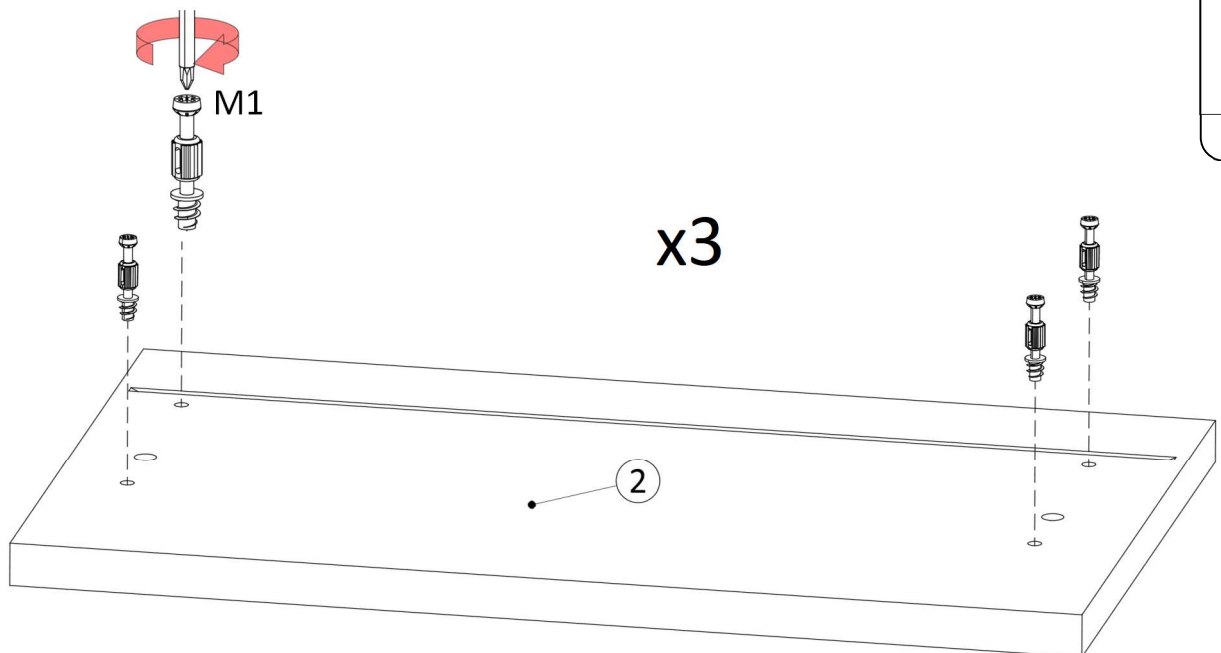
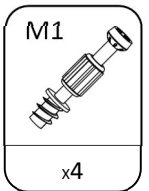

19

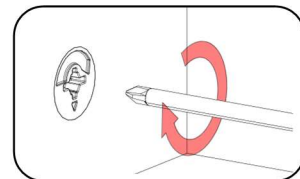
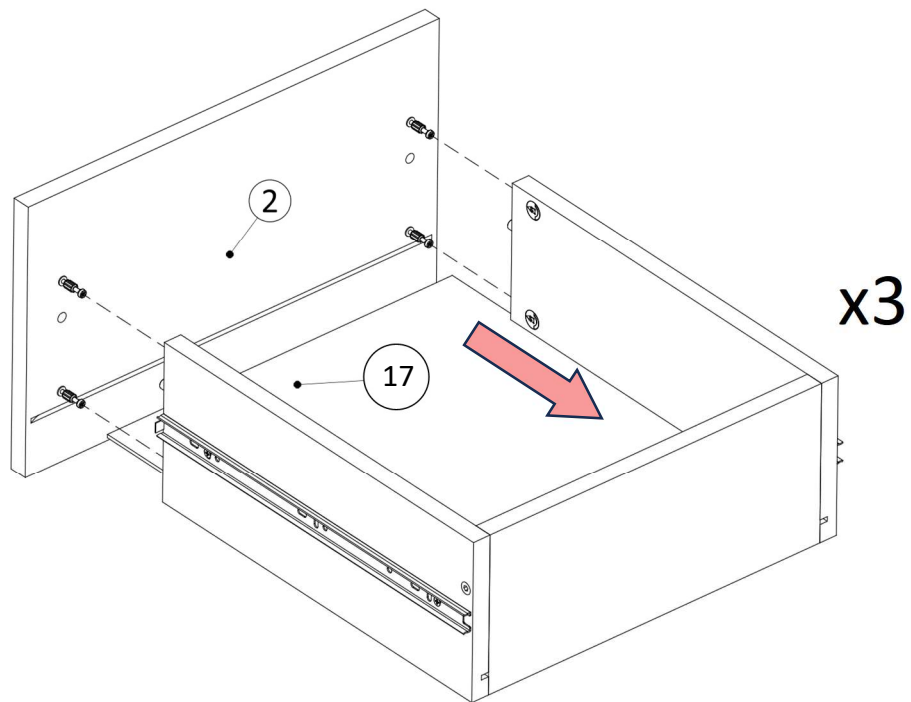

20

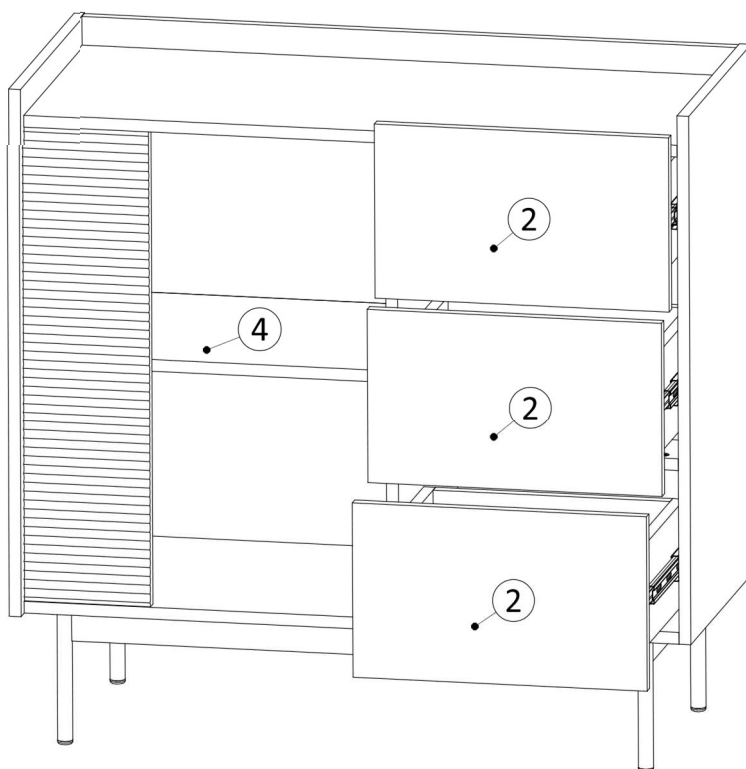
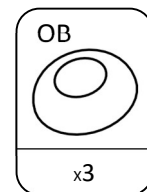
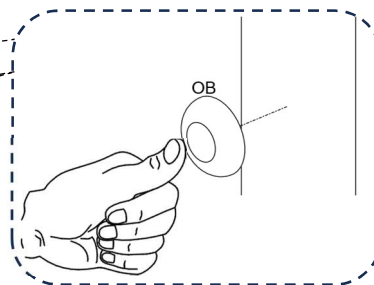

21

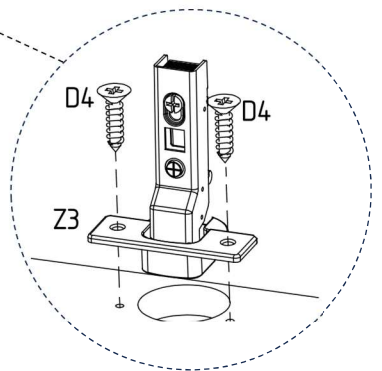
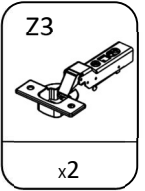
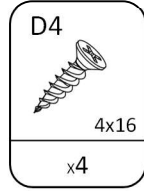
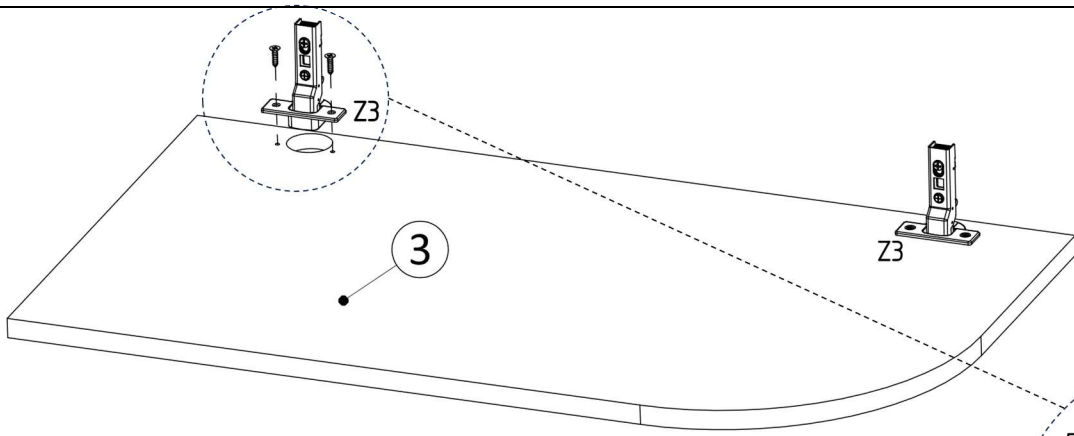

22

