

# CARMEN

R-6

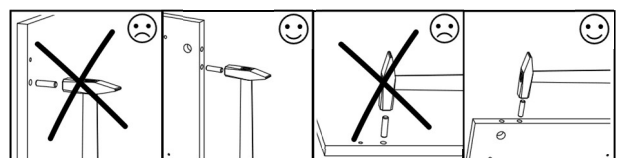

No.	T(mm)	L(mm)	W(mm)	pcs.
1	18	648	170	1
2	16	797	237	3
3	16	716	397	1
4	16	490	354	1
5	16	384	354	1
6	16	720	140	3
7	16	720	420	1
8	16	350	140	3
9	16	720	400	1
10	16	1684	200	1
11	16	1684	100	1
12	16	778	100	1
13	16	648	379	1
14	16	648	379	1
15	16	1684	383	1
16	16	1684	400	1
17	16	350	140	3
18	16	716	397	1
19	3	1692	327	1
20	3	733	346	3
21	3	1962	327	1

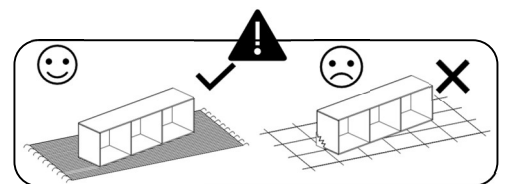
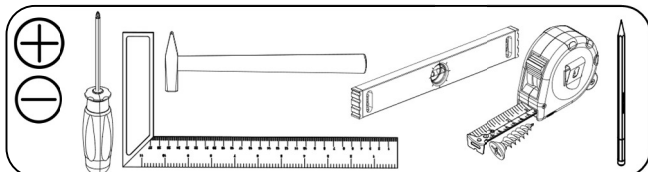
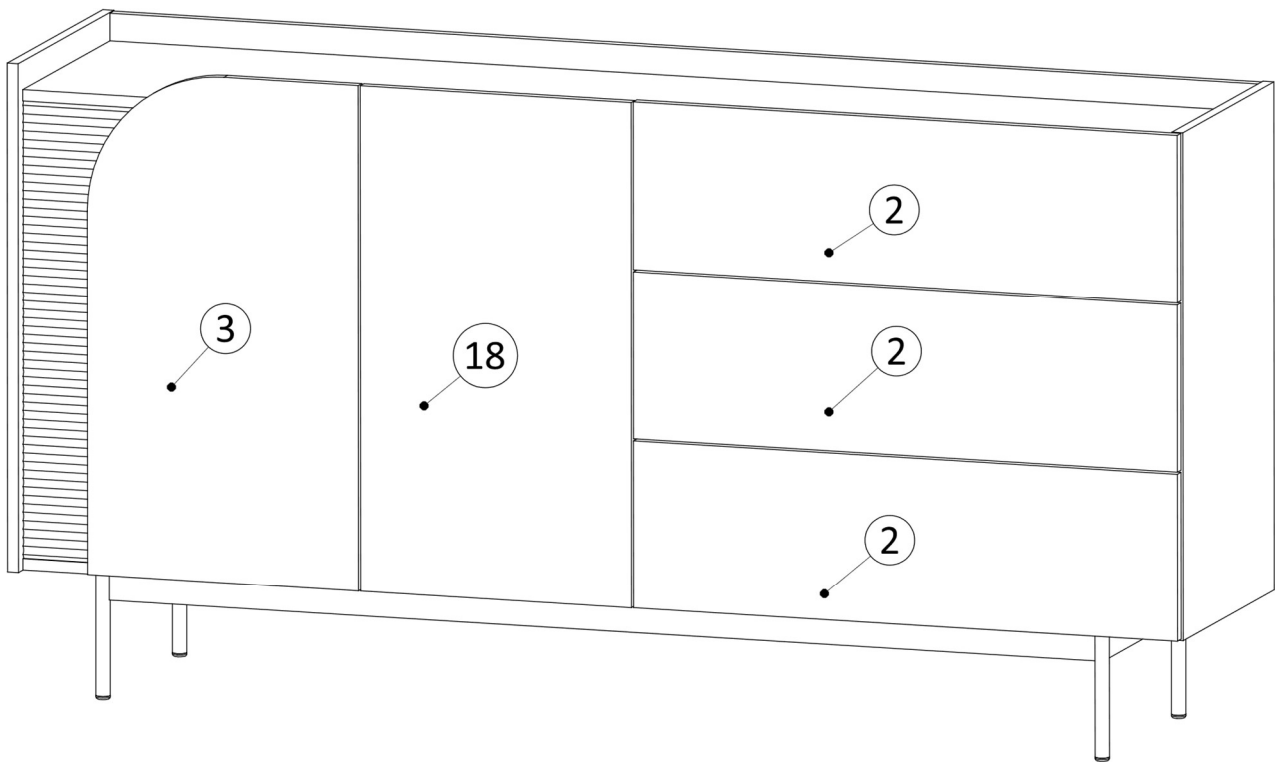
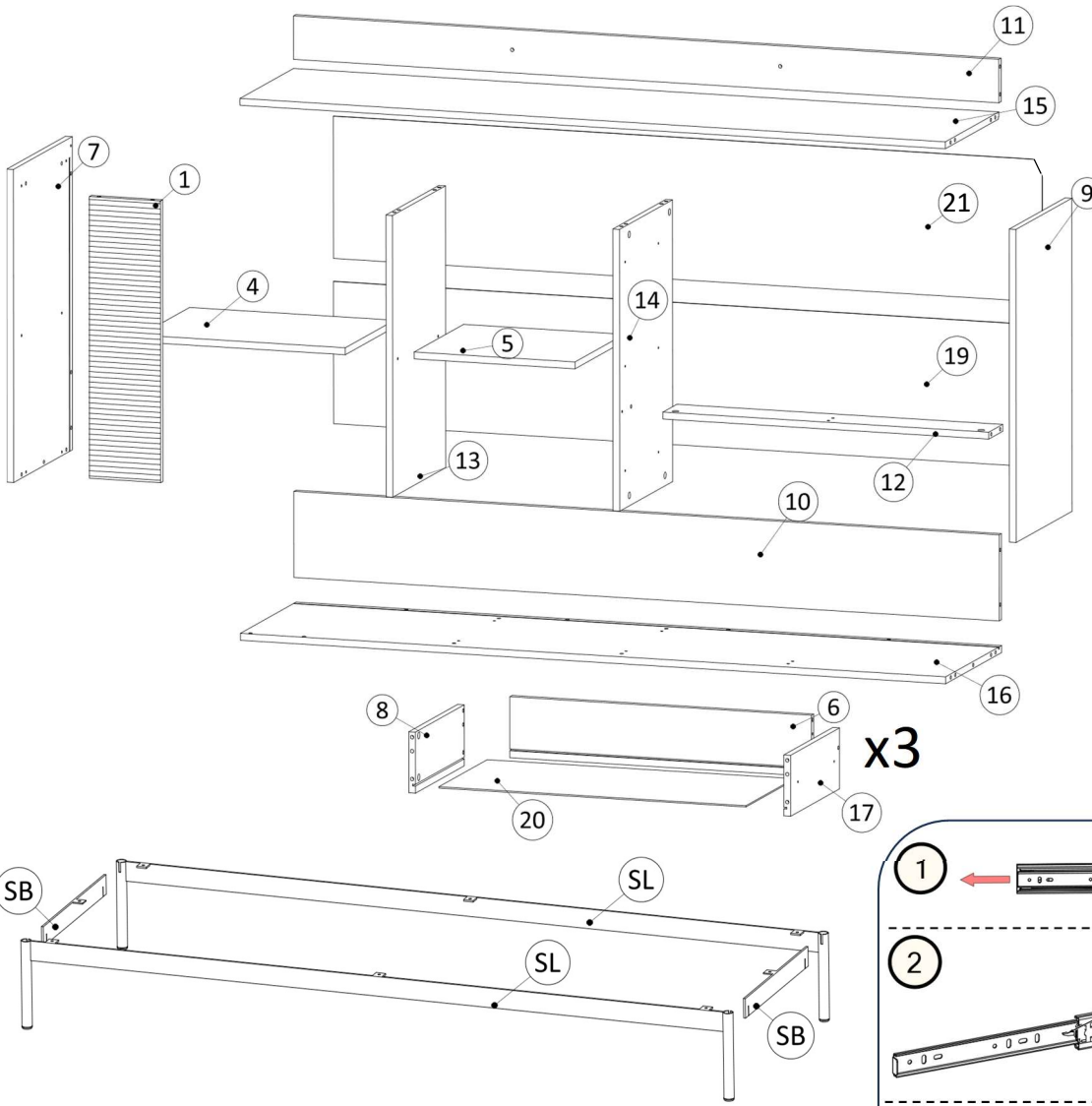

x3

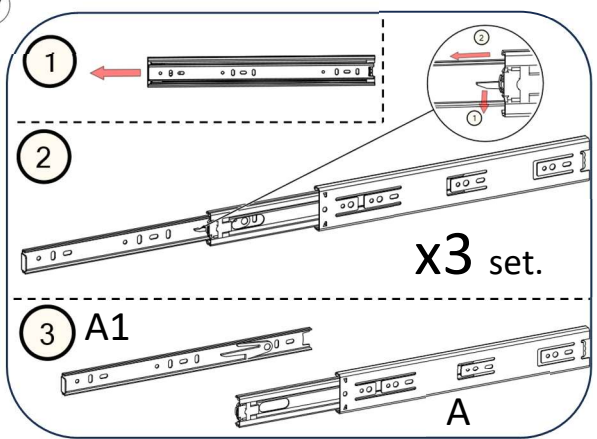

TR

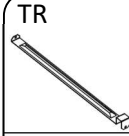

x3

MS

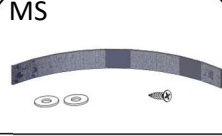

x1



K

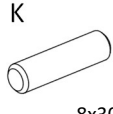

8x30

x48

M1



x32

ZM

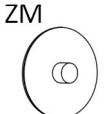

x32

Z

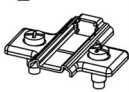

x4

P



x8

Z3



x4

D5



3x13

x6

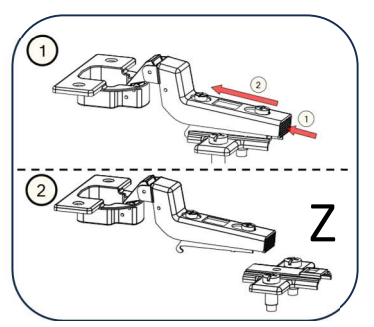

M



x32

OB

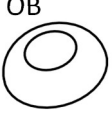

x4

F

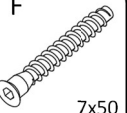

7x50

x12

KL

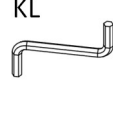

x1

T

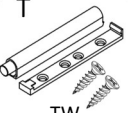

TW

x2

Y

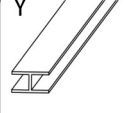

x1

S



x2

D4



4x16

x16

G

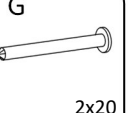

2x20

x10

E1

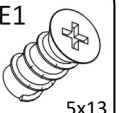

5x13

x24

1

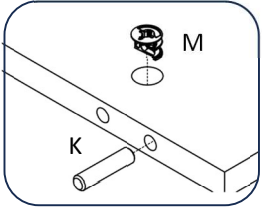
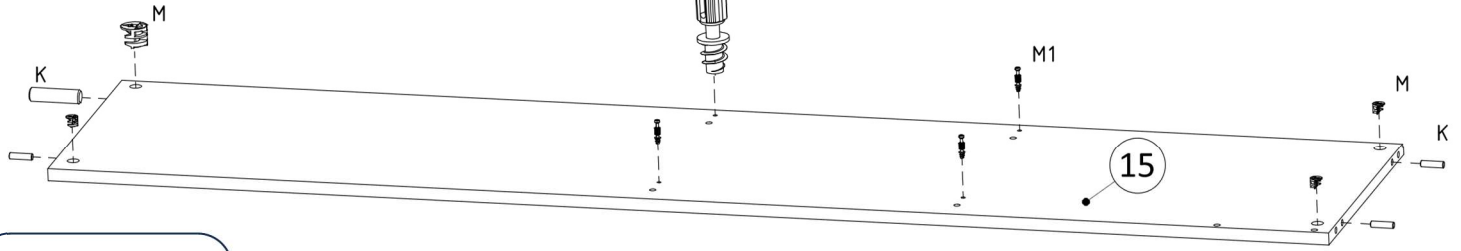
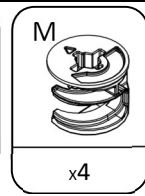
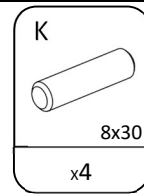
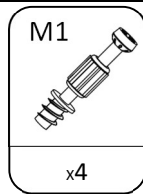
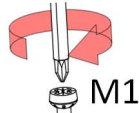
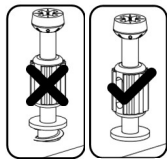

2

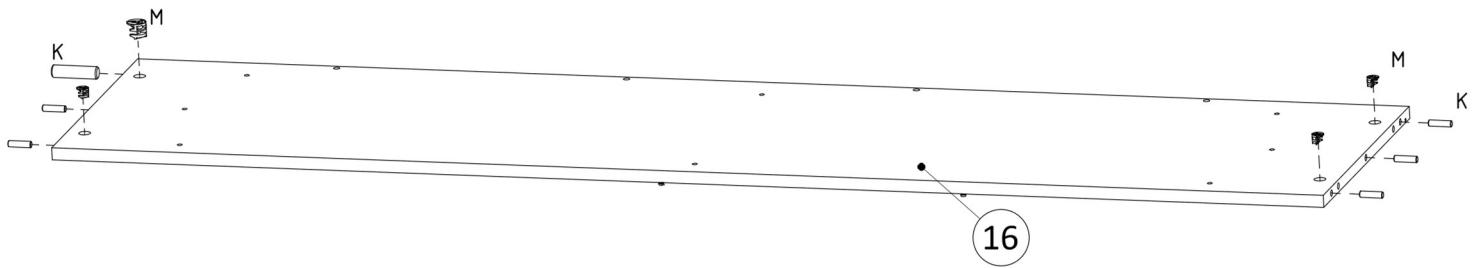
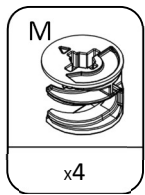
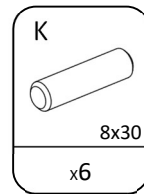
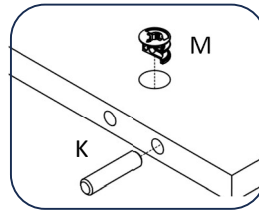

3

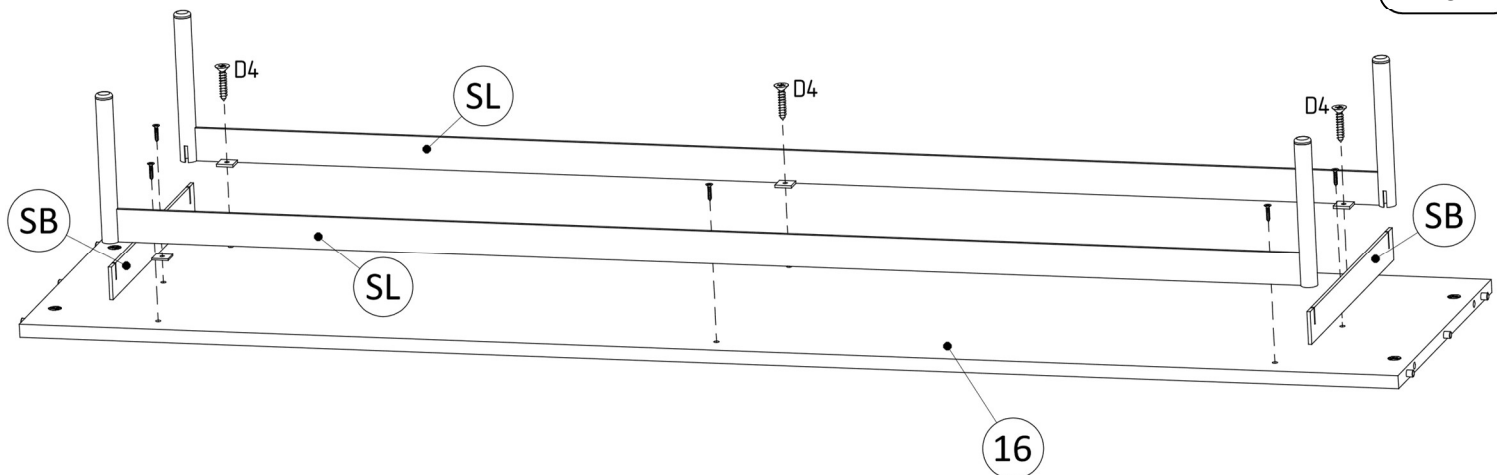
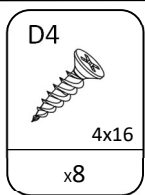

4

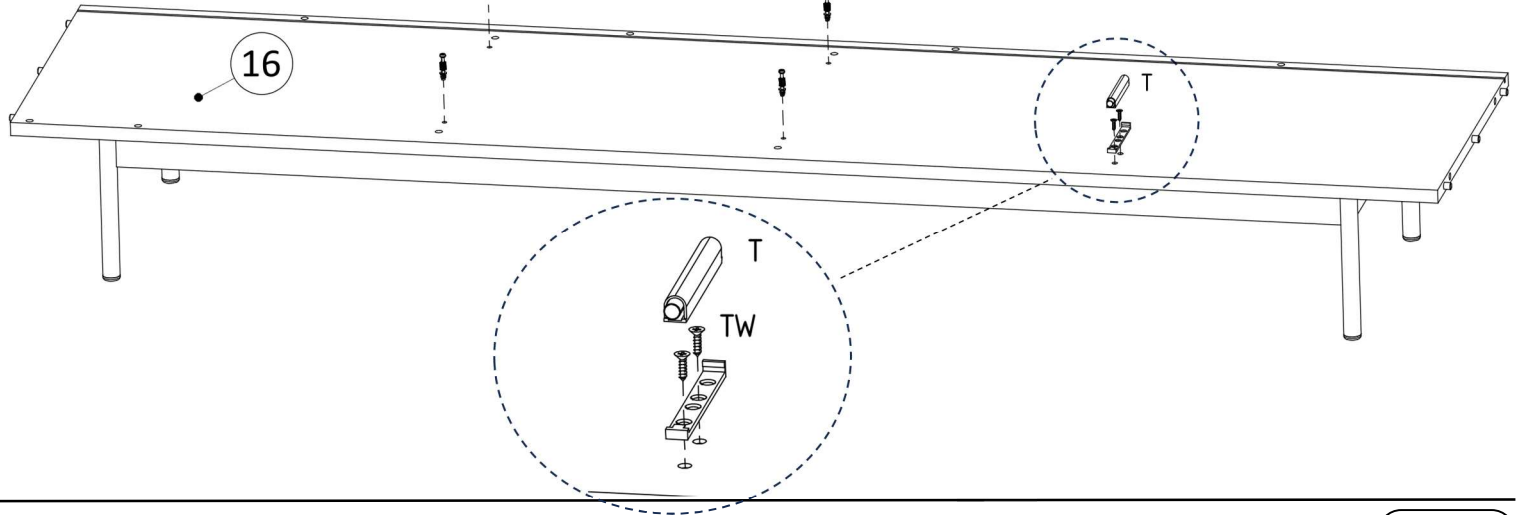
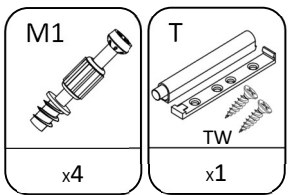
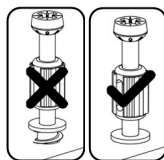
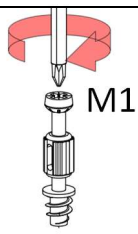

5

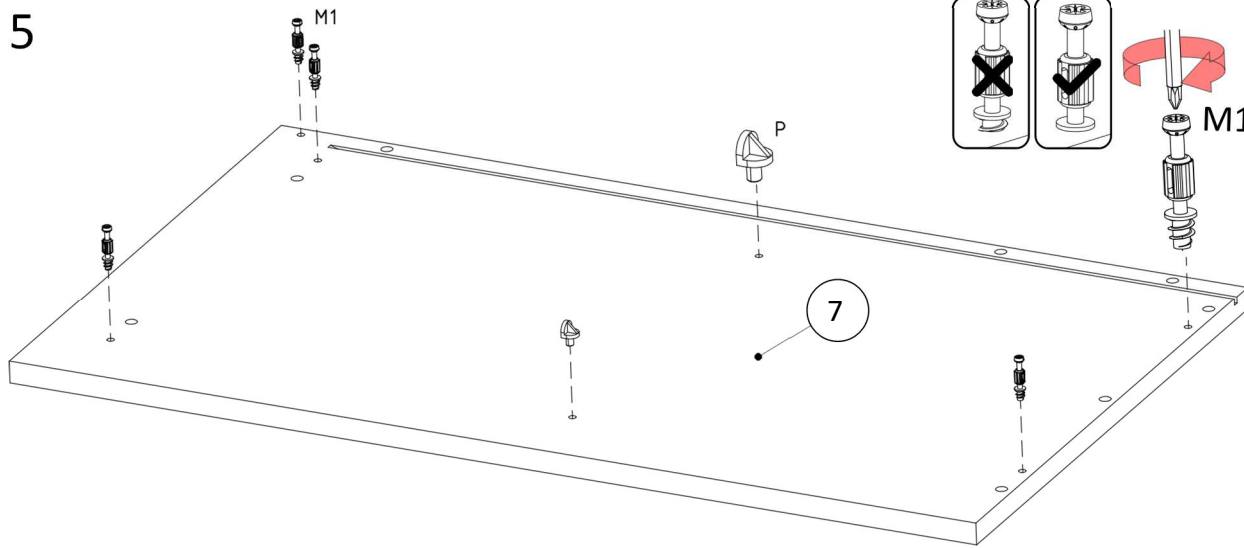
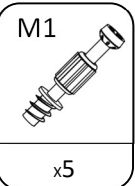
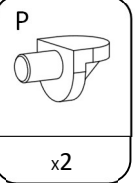
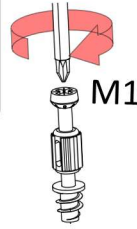
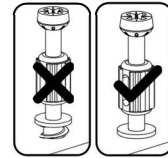

6

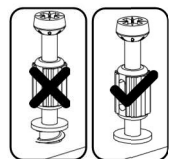
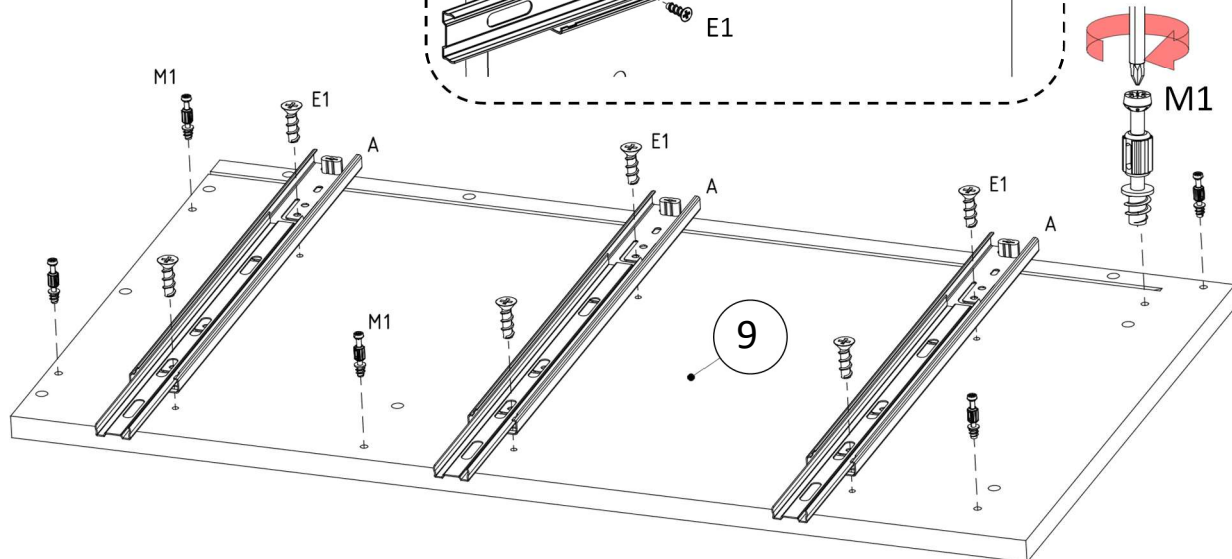
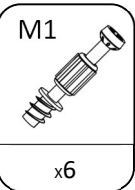
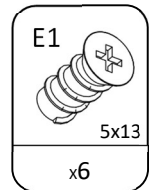
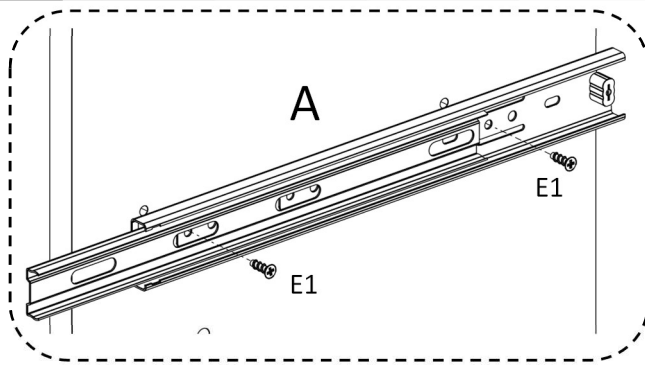

7

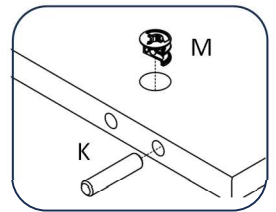
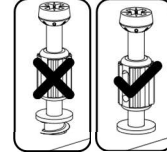
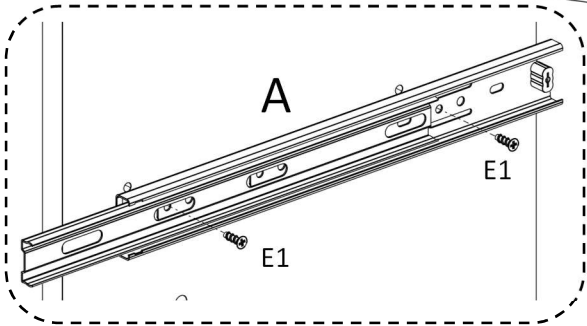
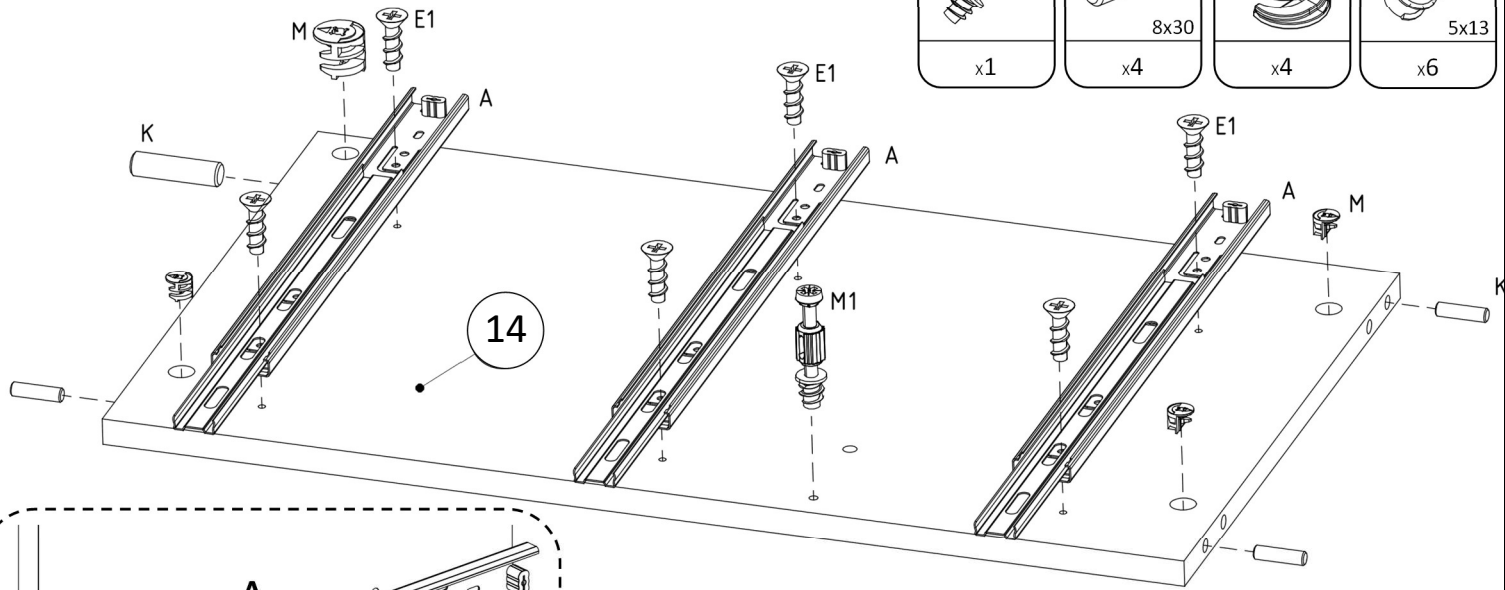
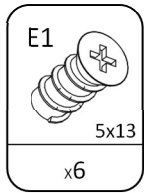
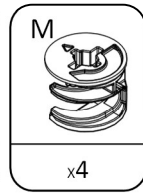
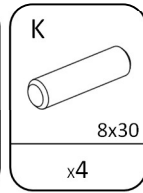
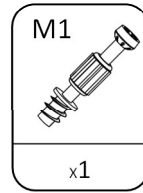

8

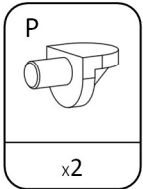
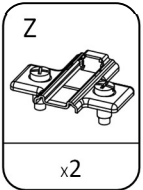
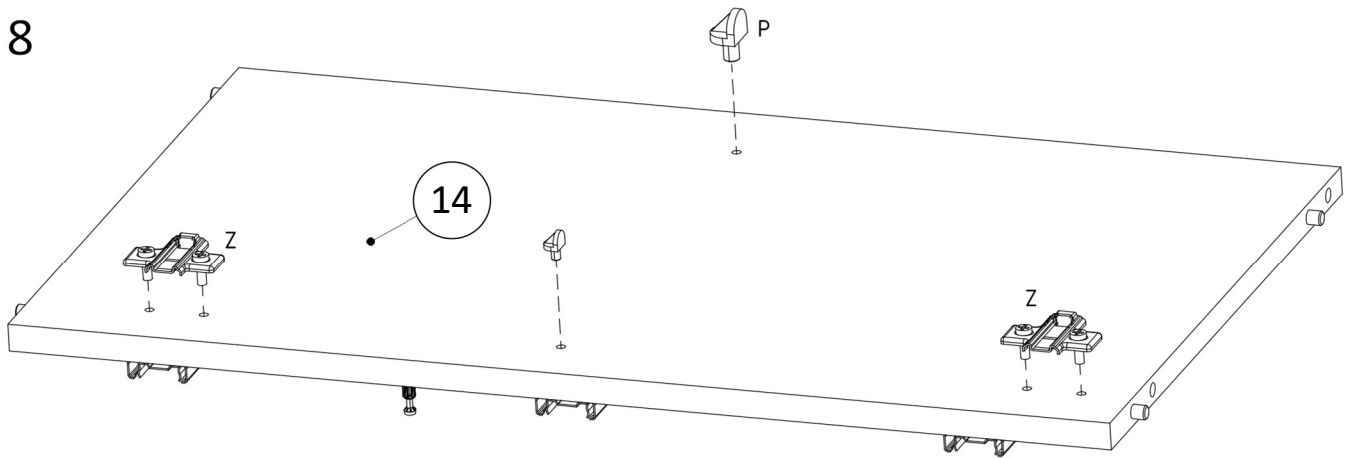

9

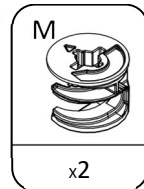
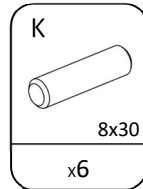
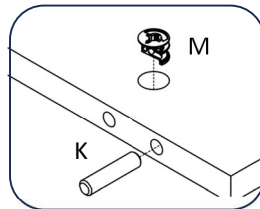
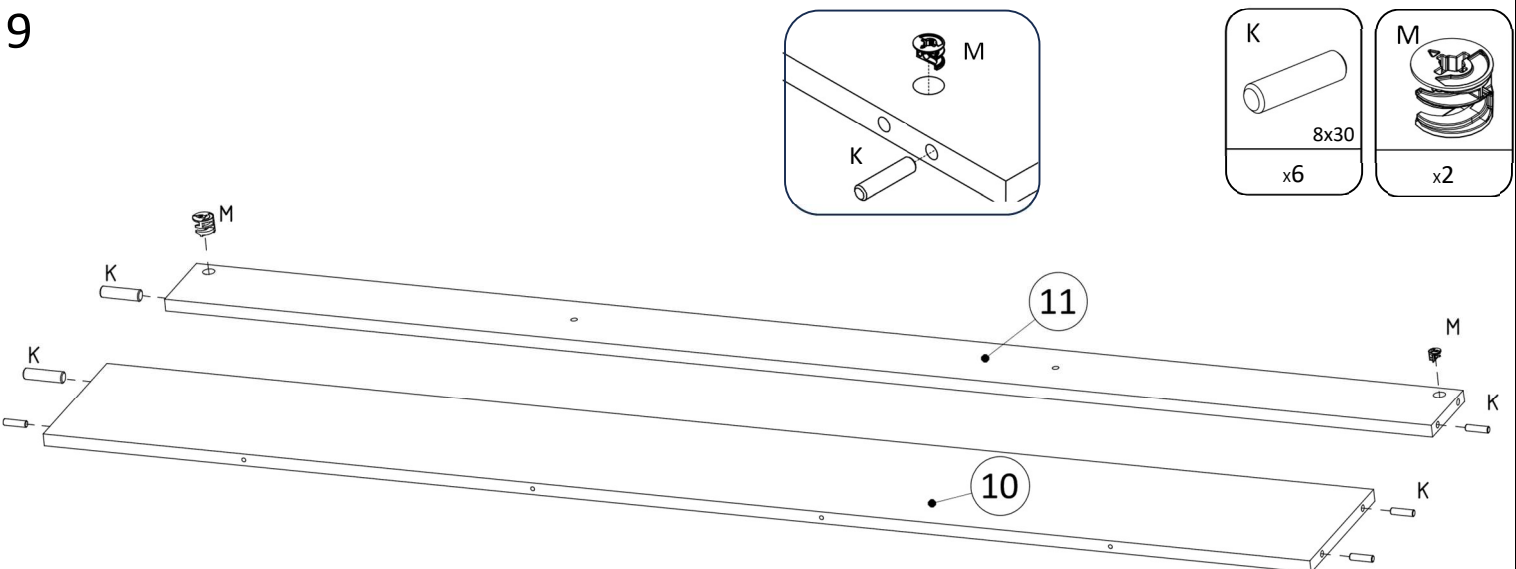

10

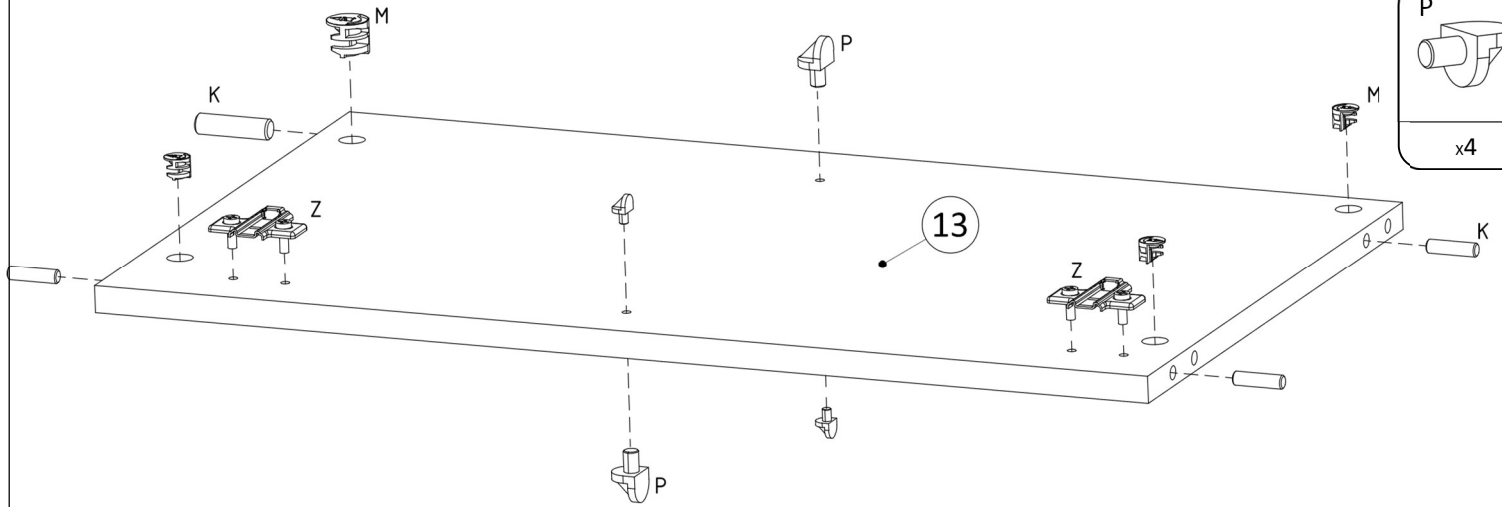
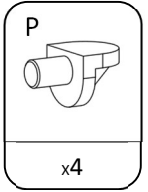
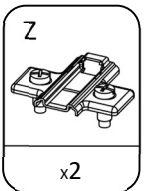
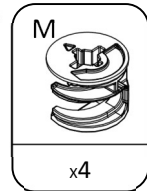
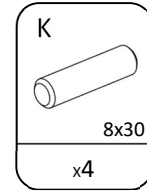
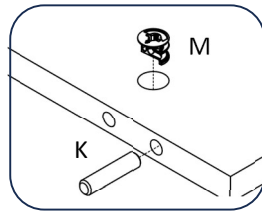

11

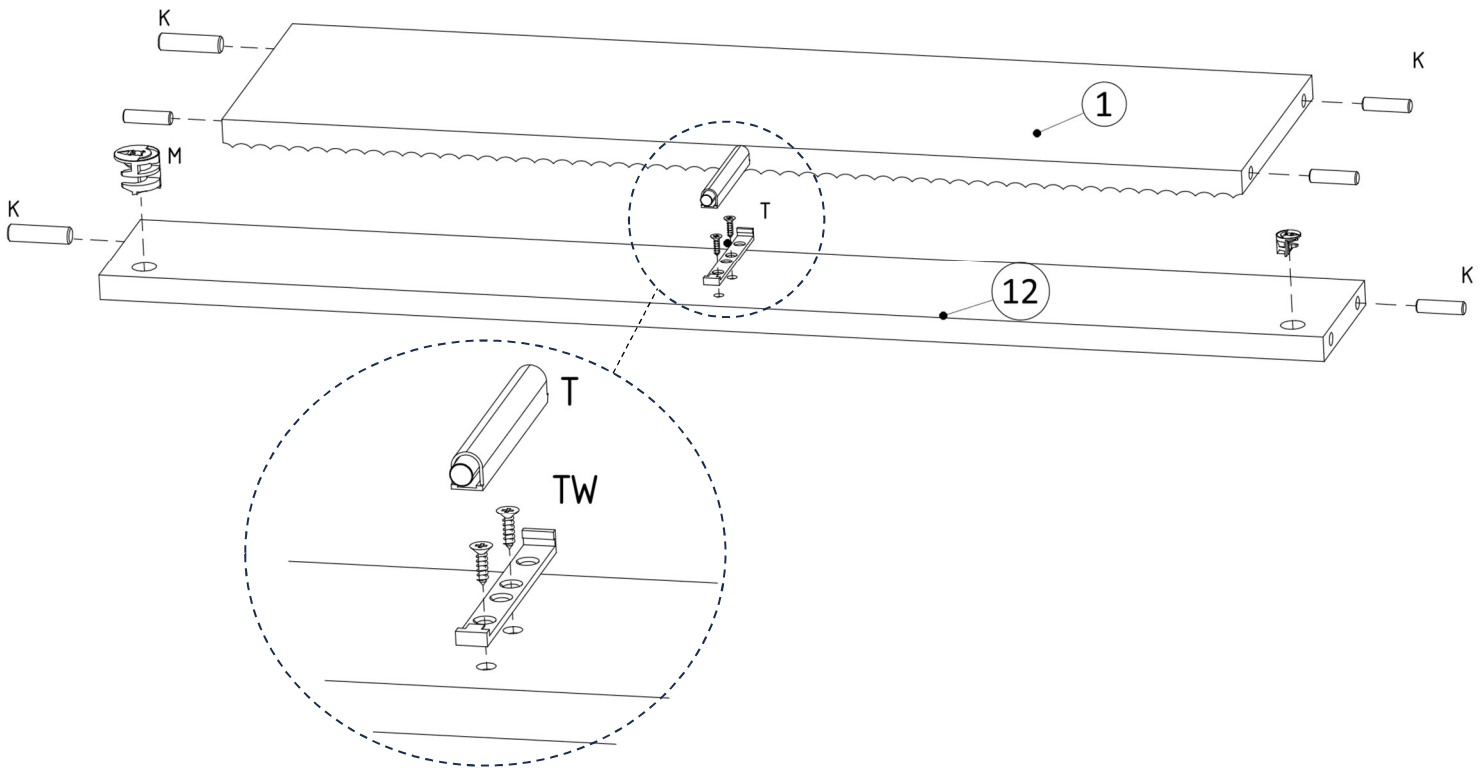
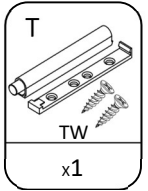
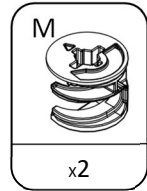
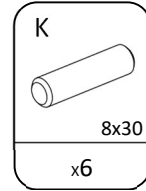
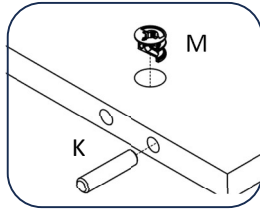

12

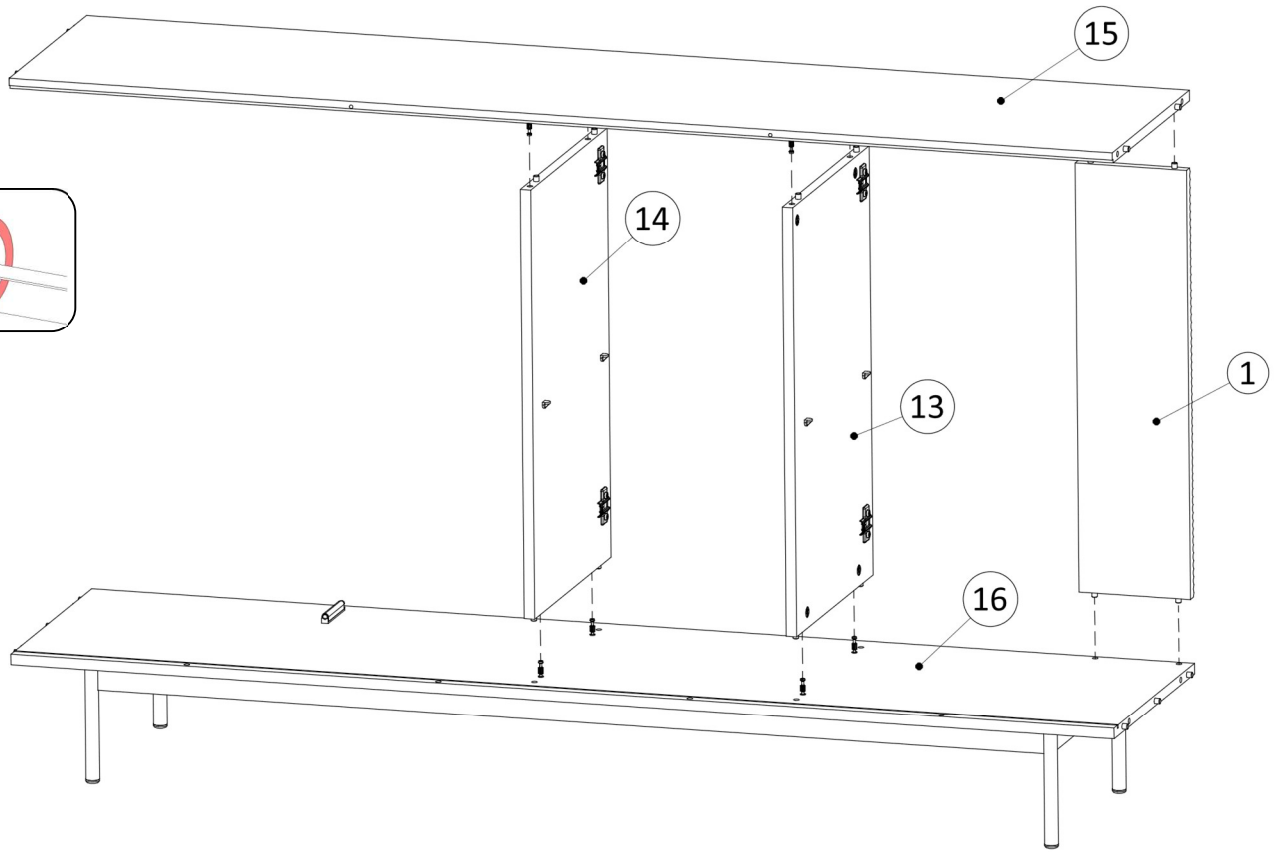
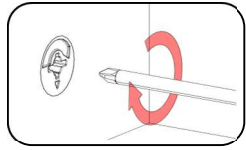

13

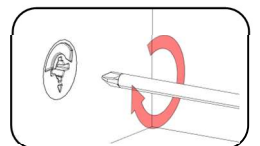
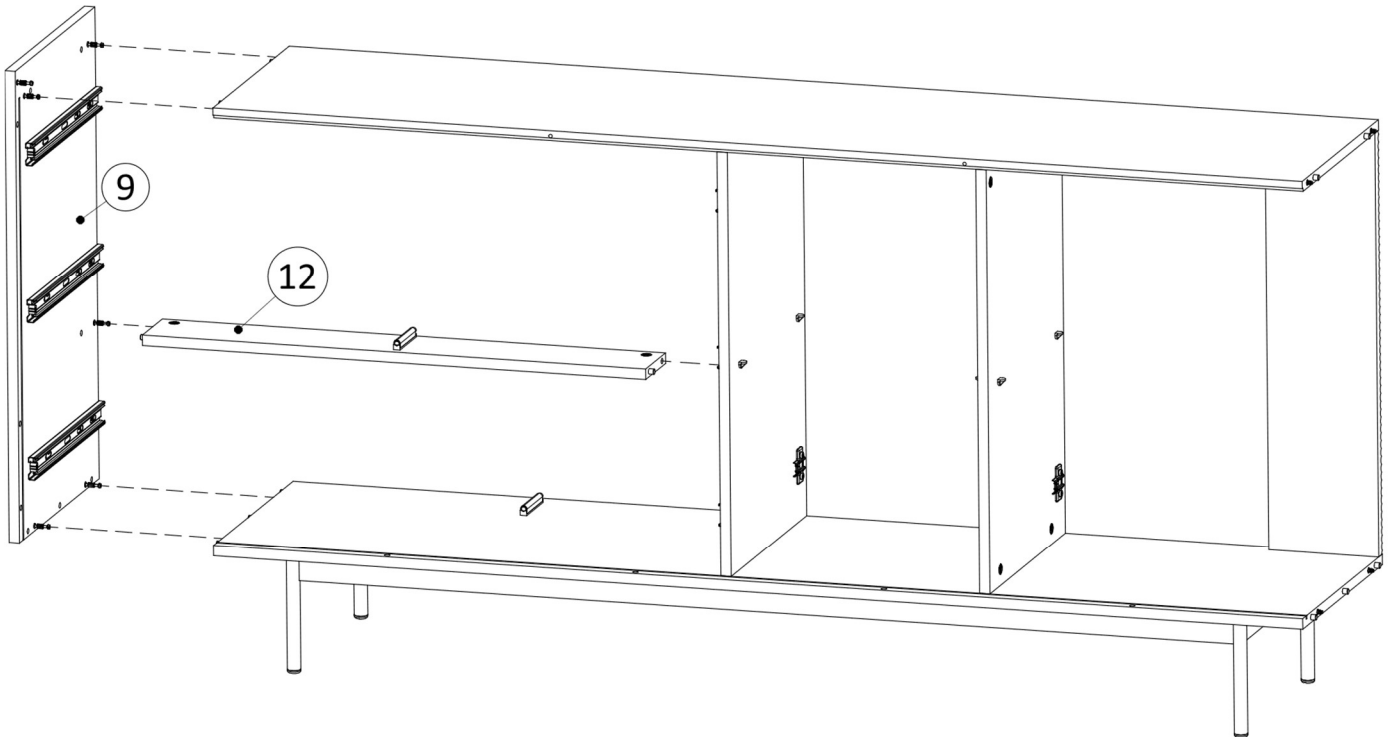

14

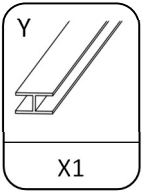
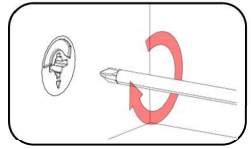
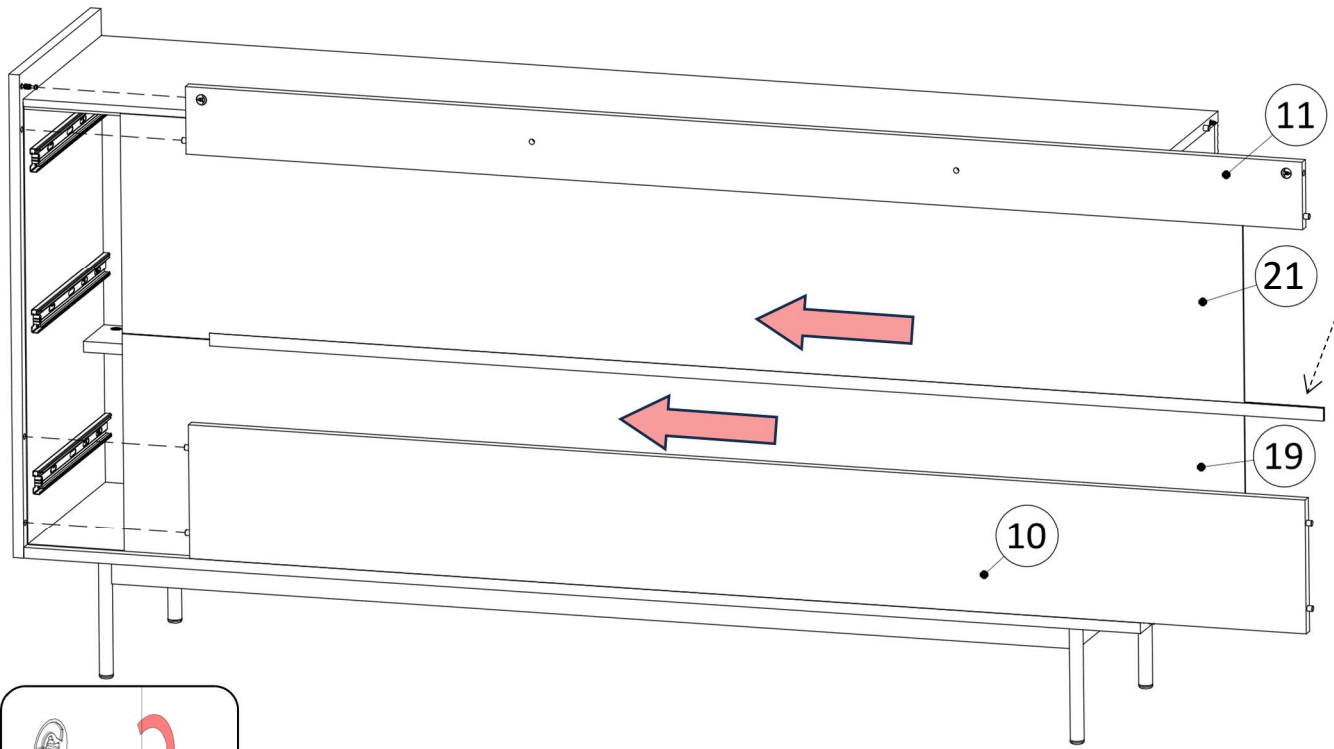

15

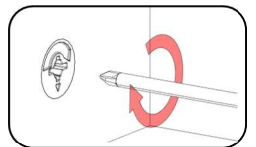
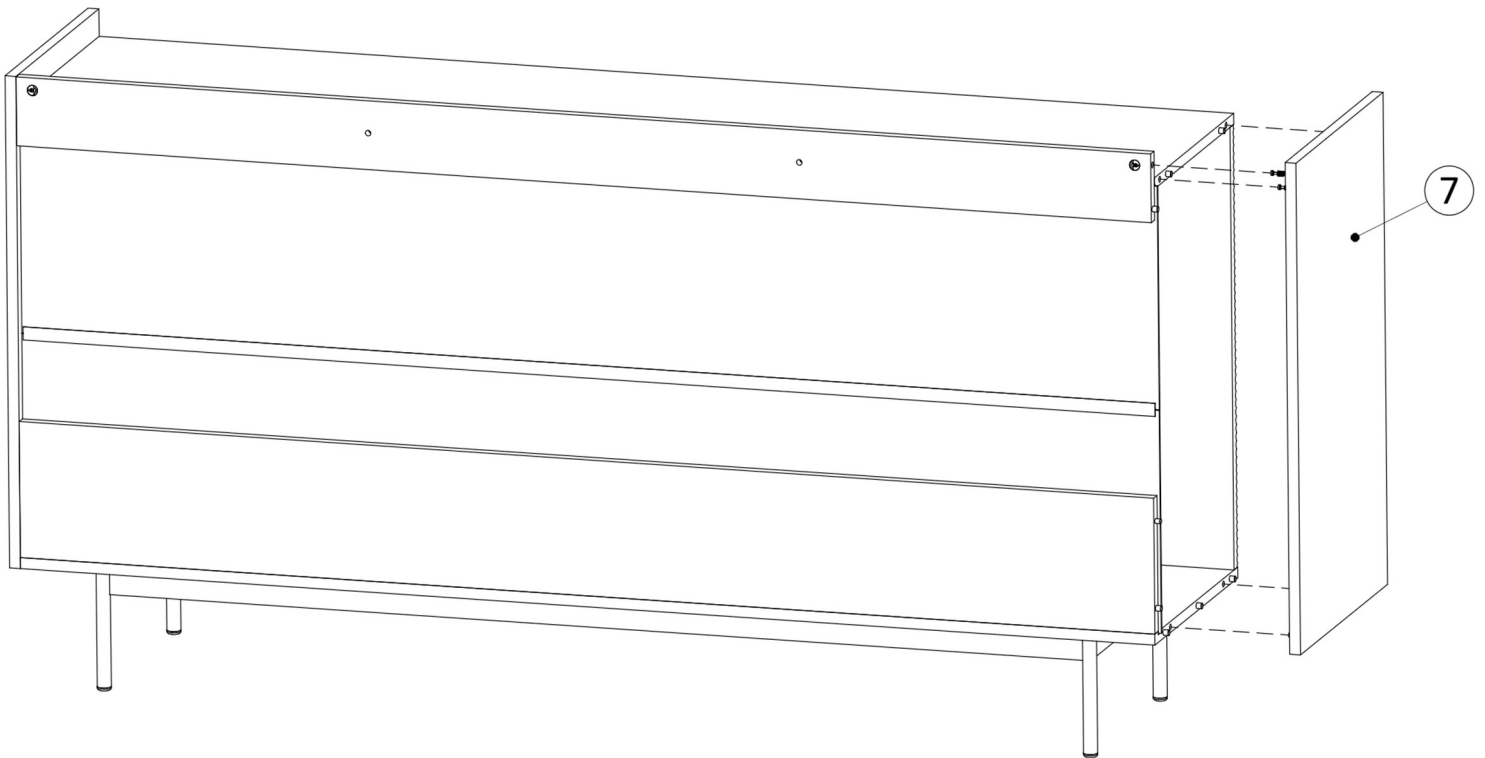

16

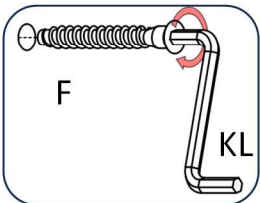
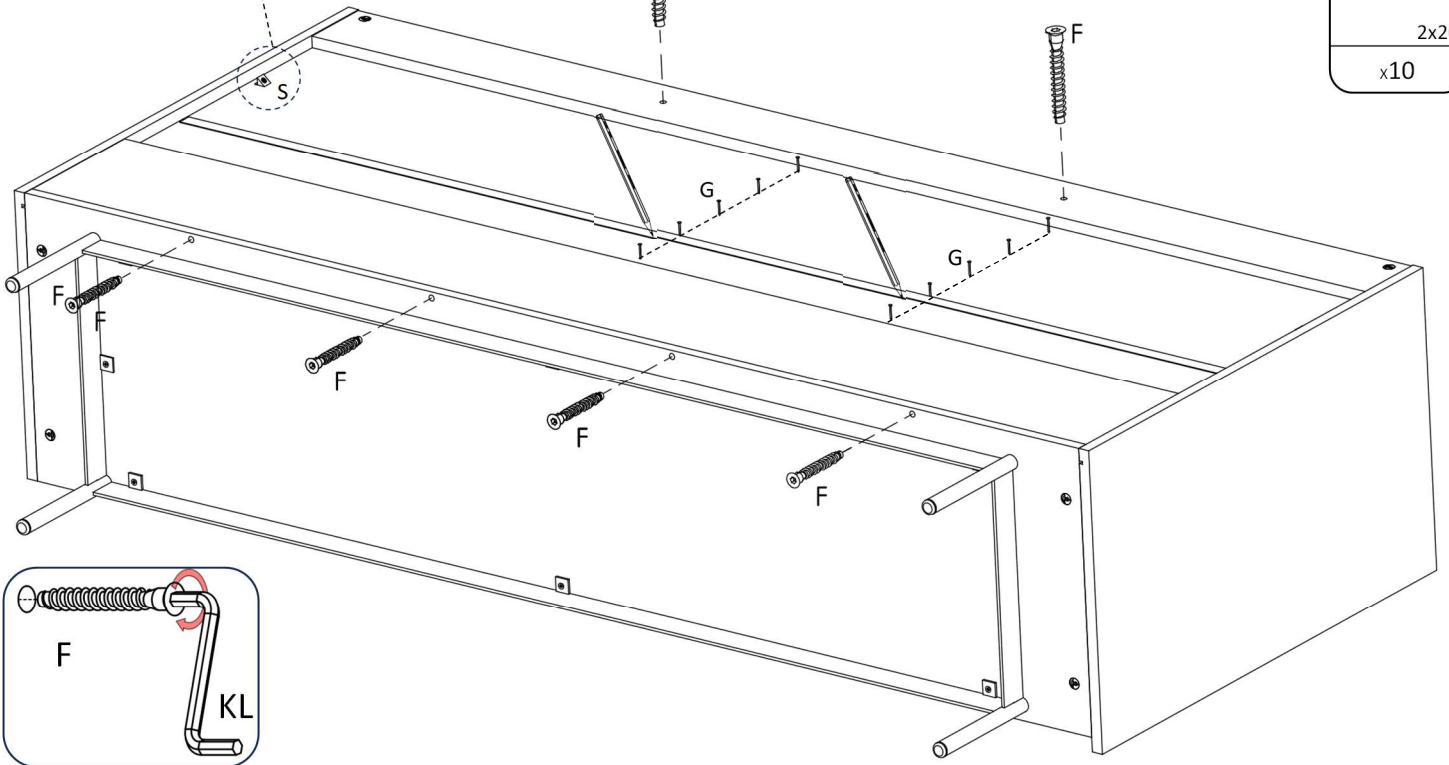
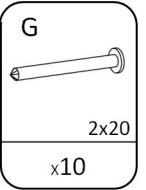
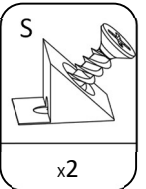
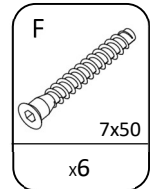
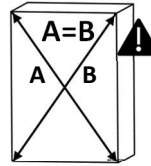
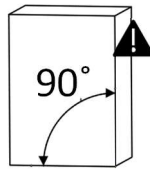
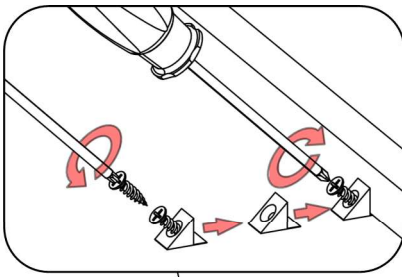

17

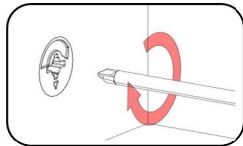

x3

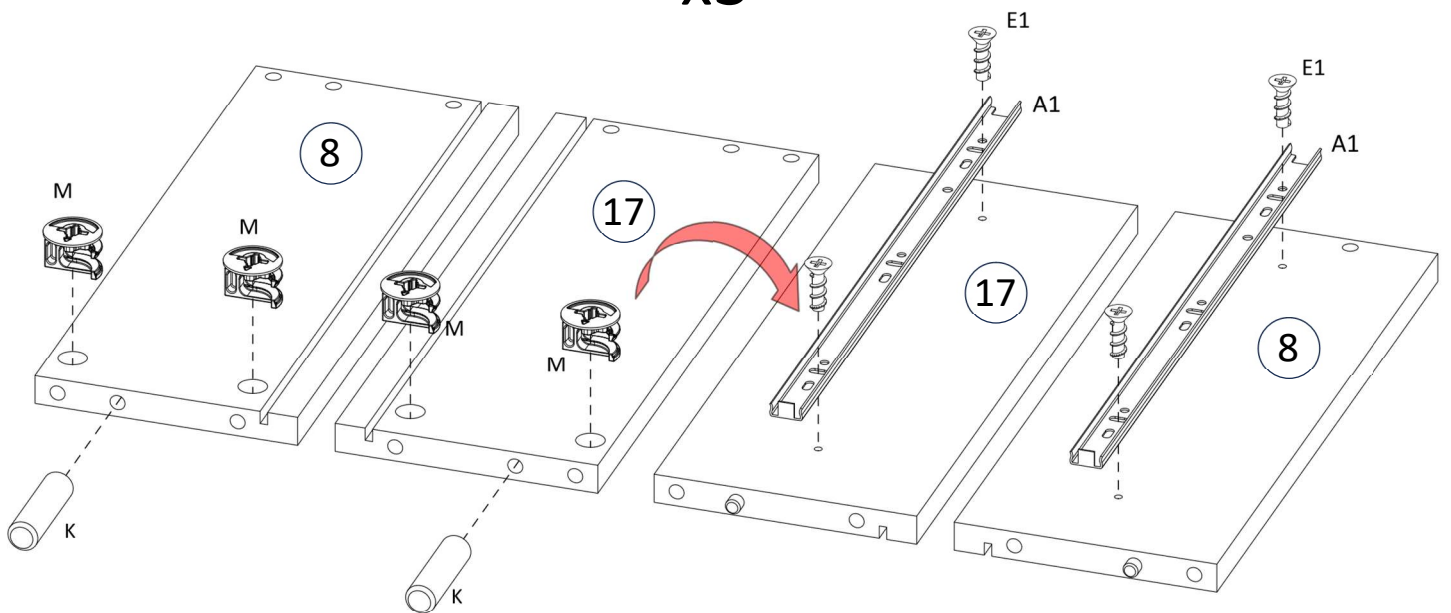
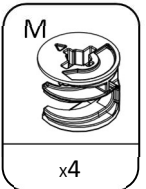
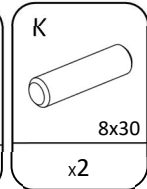
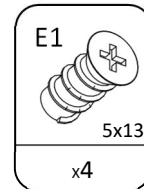

18

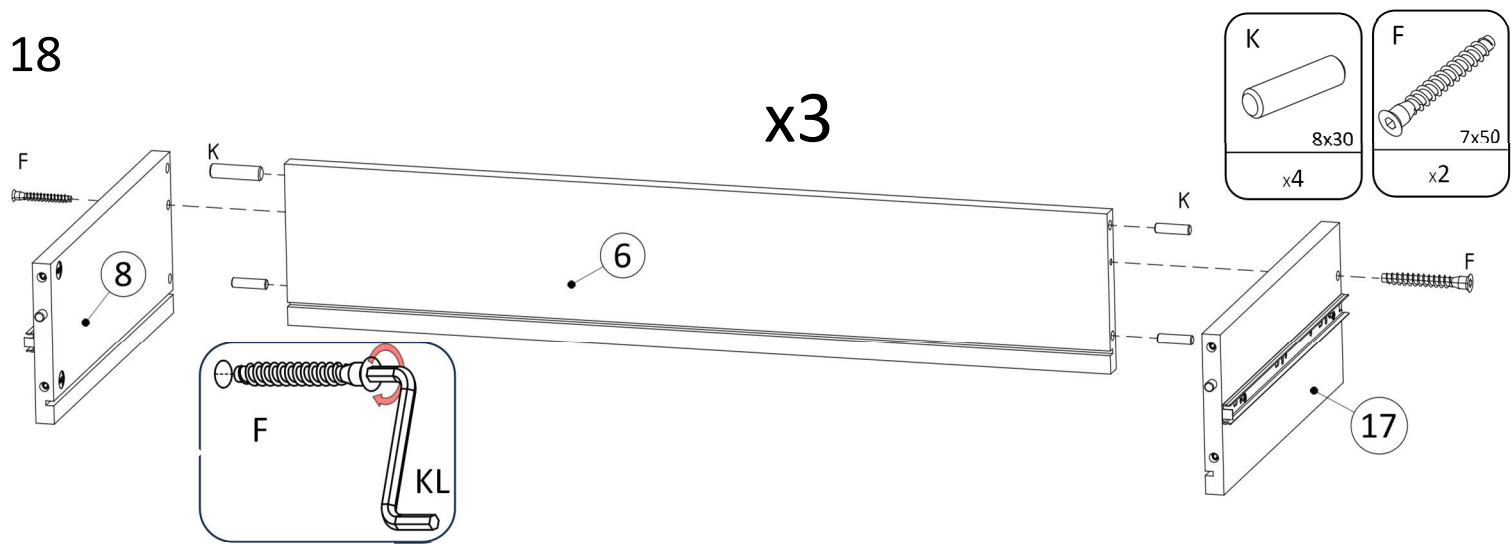

19

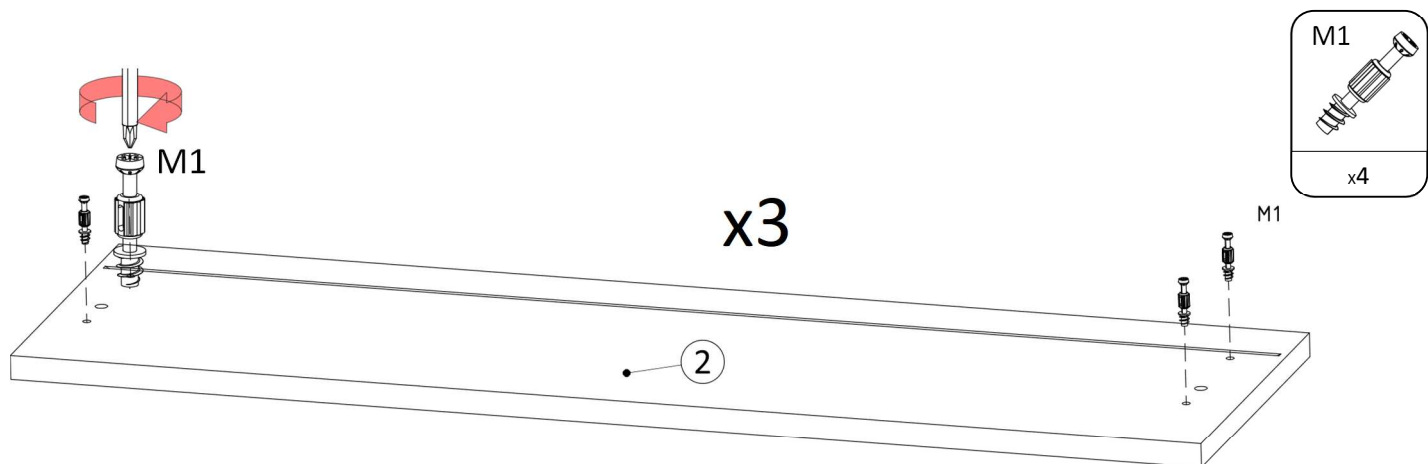

20

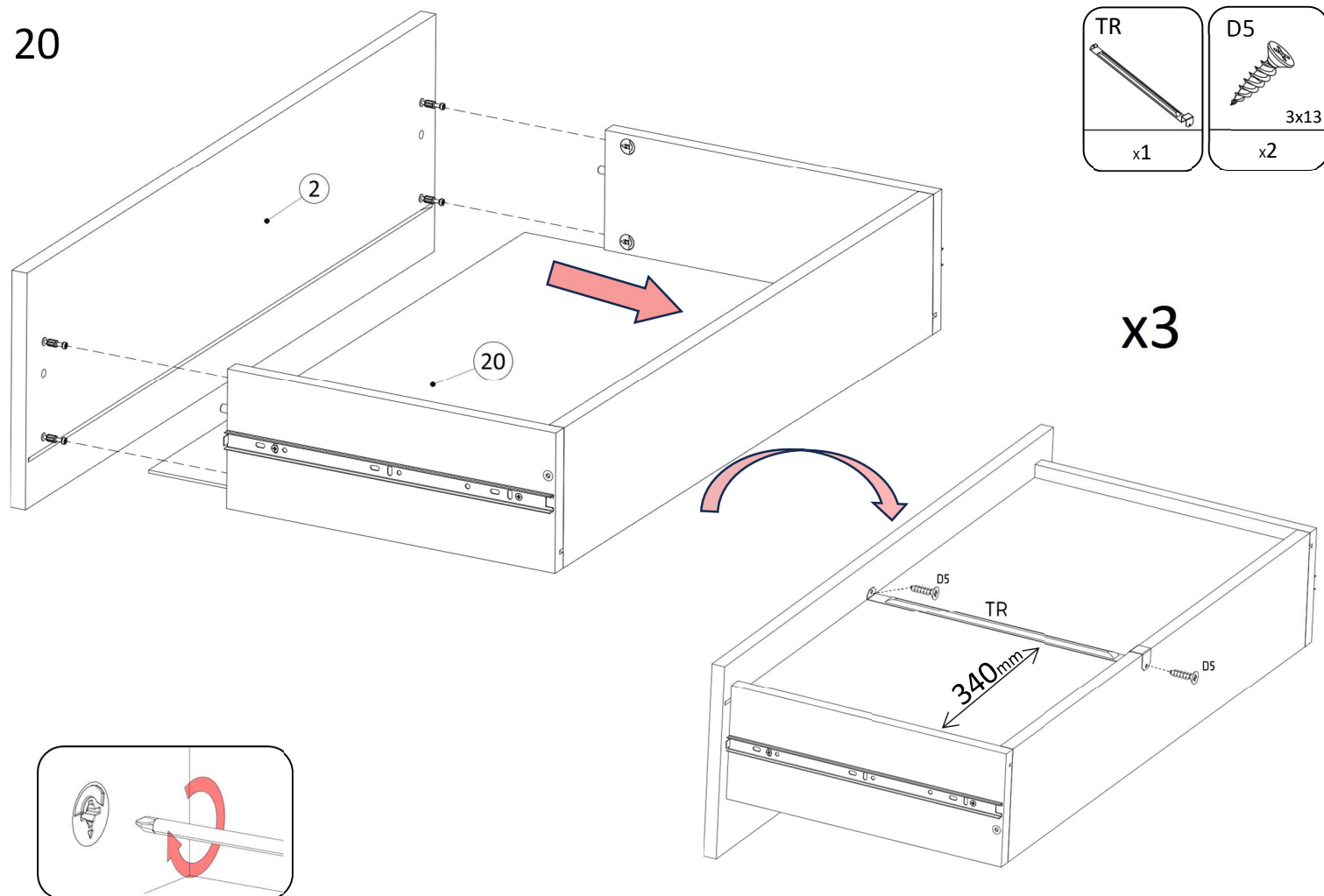

21

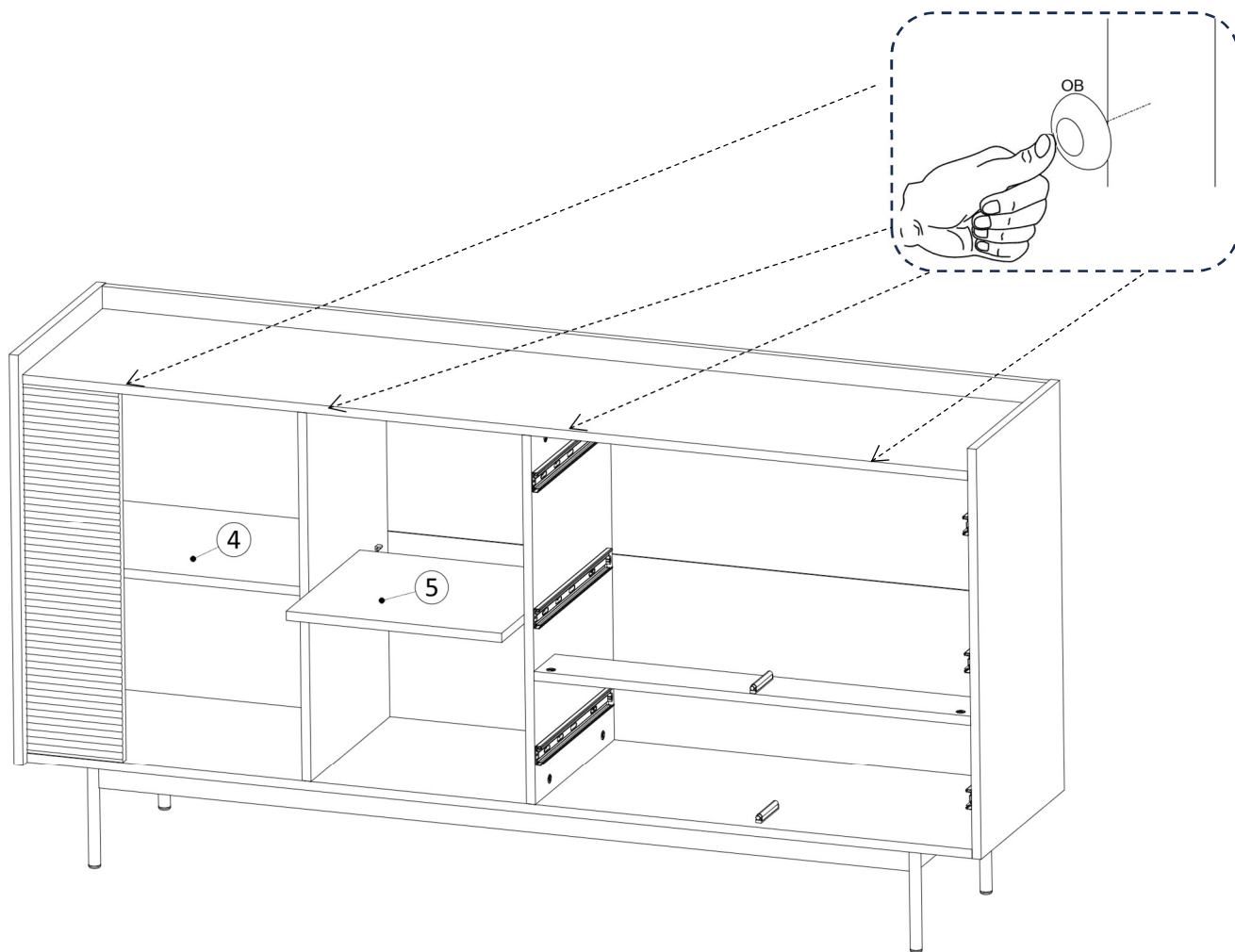
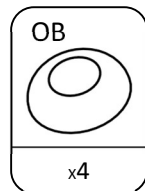

22

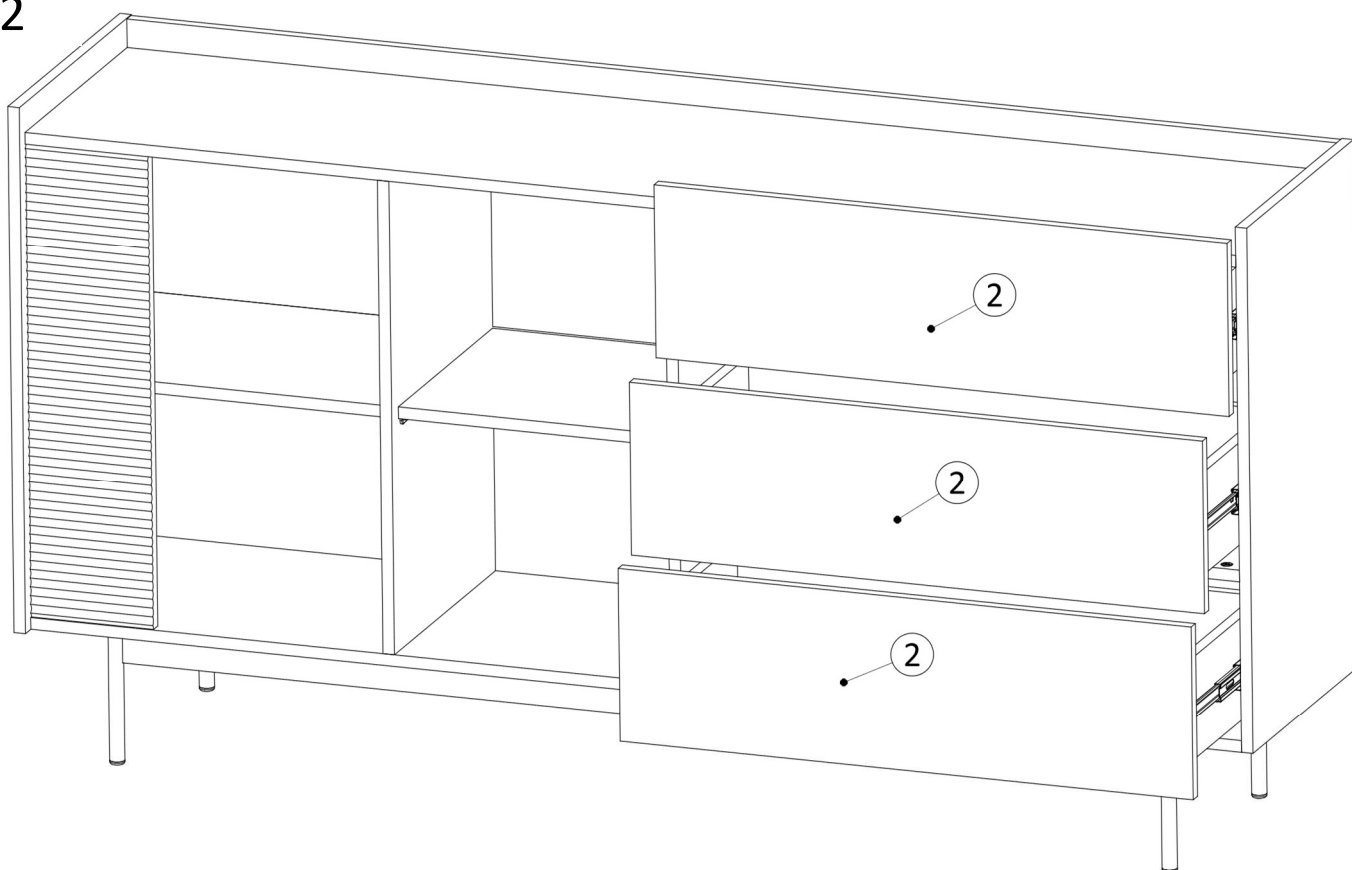

23

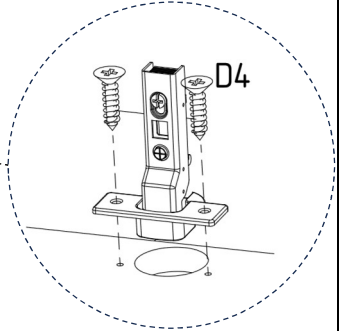
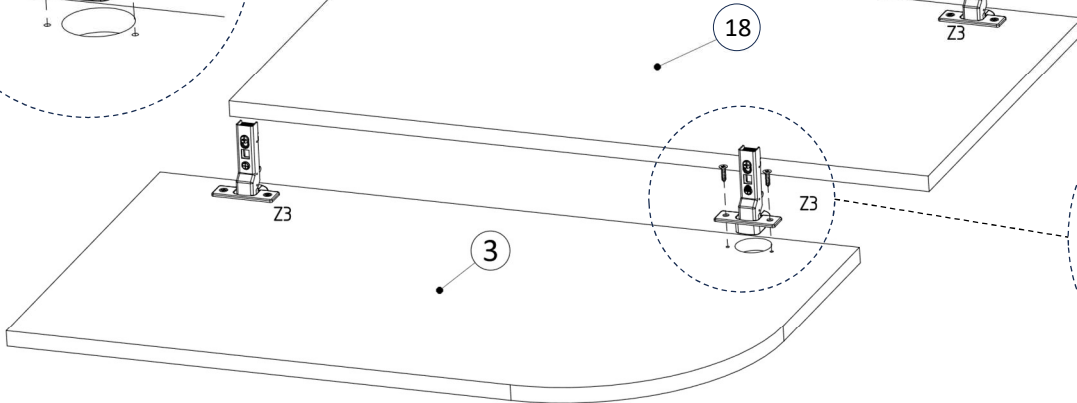
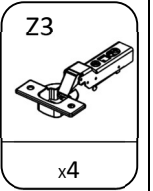
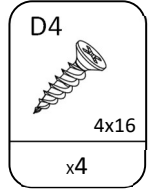
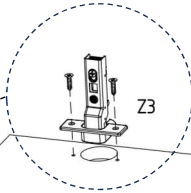
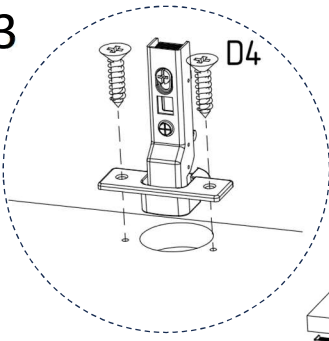

24

