

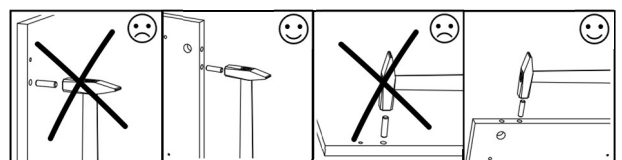

# CARMEN

R-5

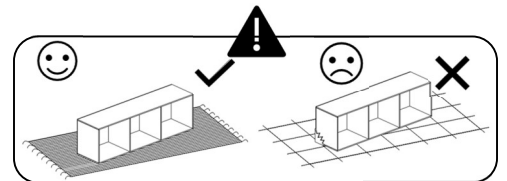
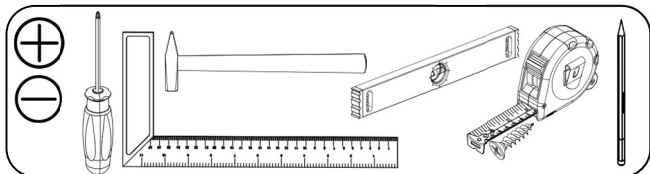
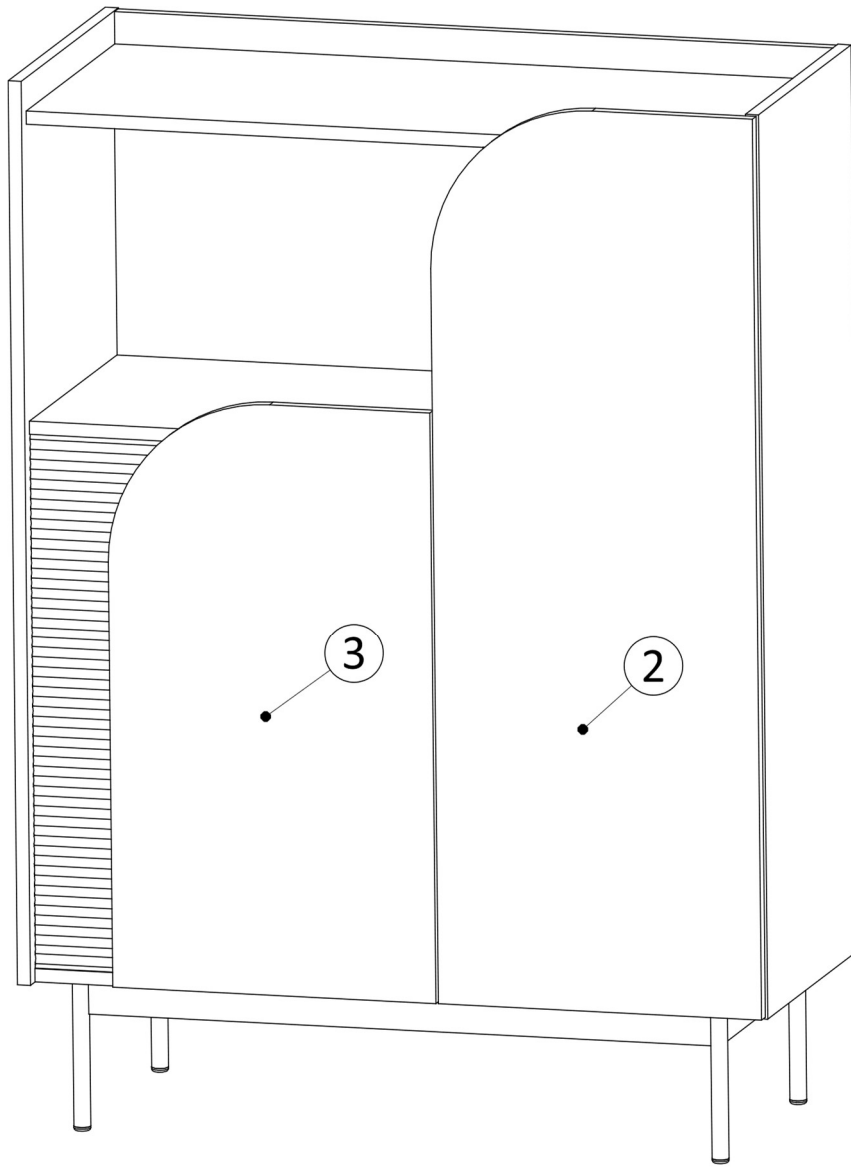
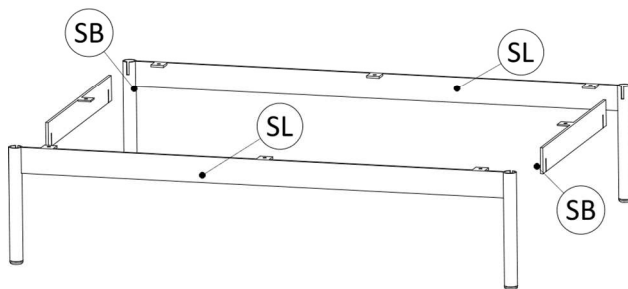
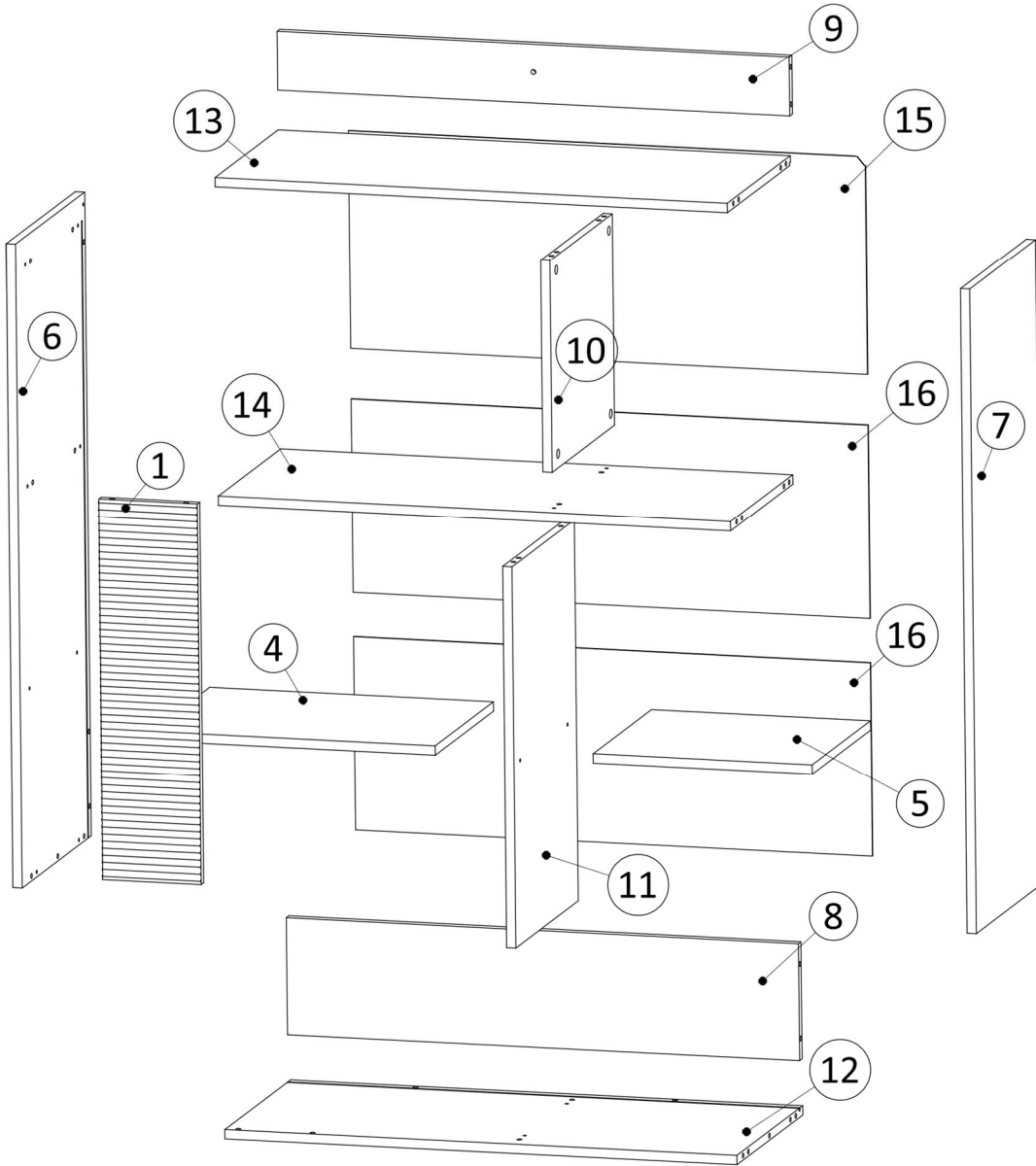

No	T(mm)	L(mm)	W(mm)	pcs.
1	18	648	170	1
2	16	1092	397	1
3	16	716	397	1
4	16	490	354	1
5	16	378	354	1
6	16	1096	420	1
7	16	1096	400	1
8	16	884	200	1
9	16	884	100	1
10	16	360	379	1
11	16	648	379	1
12	16	884	400	1
13	16	884	383	1
14	16	884	379	1
15	3	892	371	1
16	3	892	329	2

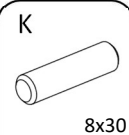
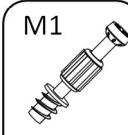
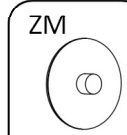
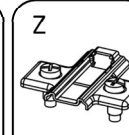
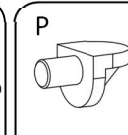
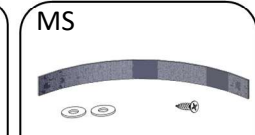

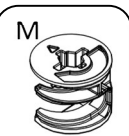
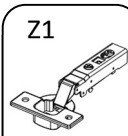
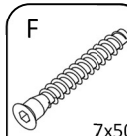
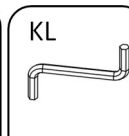
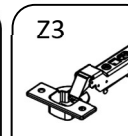
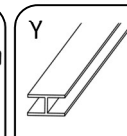
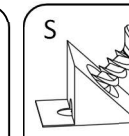
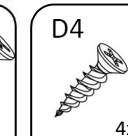
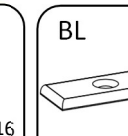
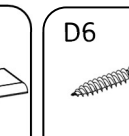
 x32	 x22	 x22	 x4	 x8	 x1				
 x22	 x2	 x3	 x1	 x2	 x1	 x4	 x16	 x9	 x9

1

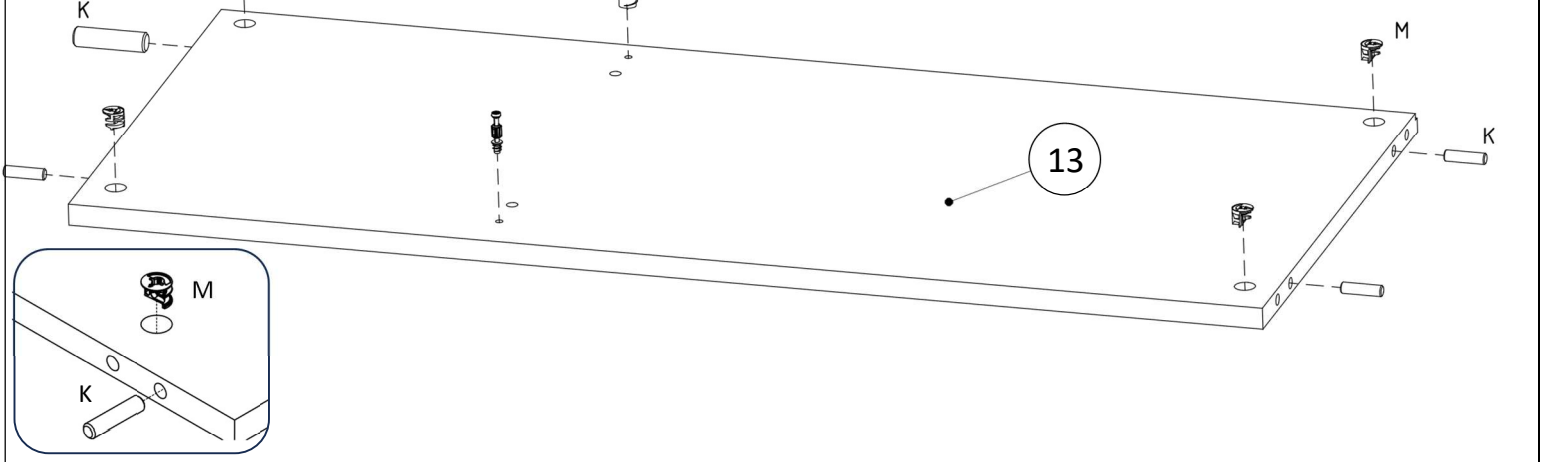
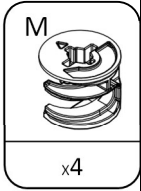
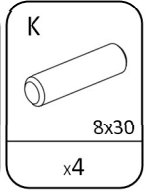
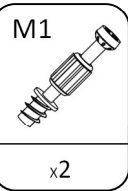
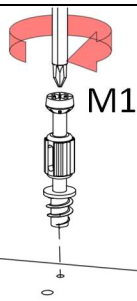
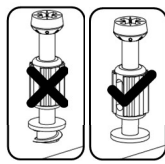

2

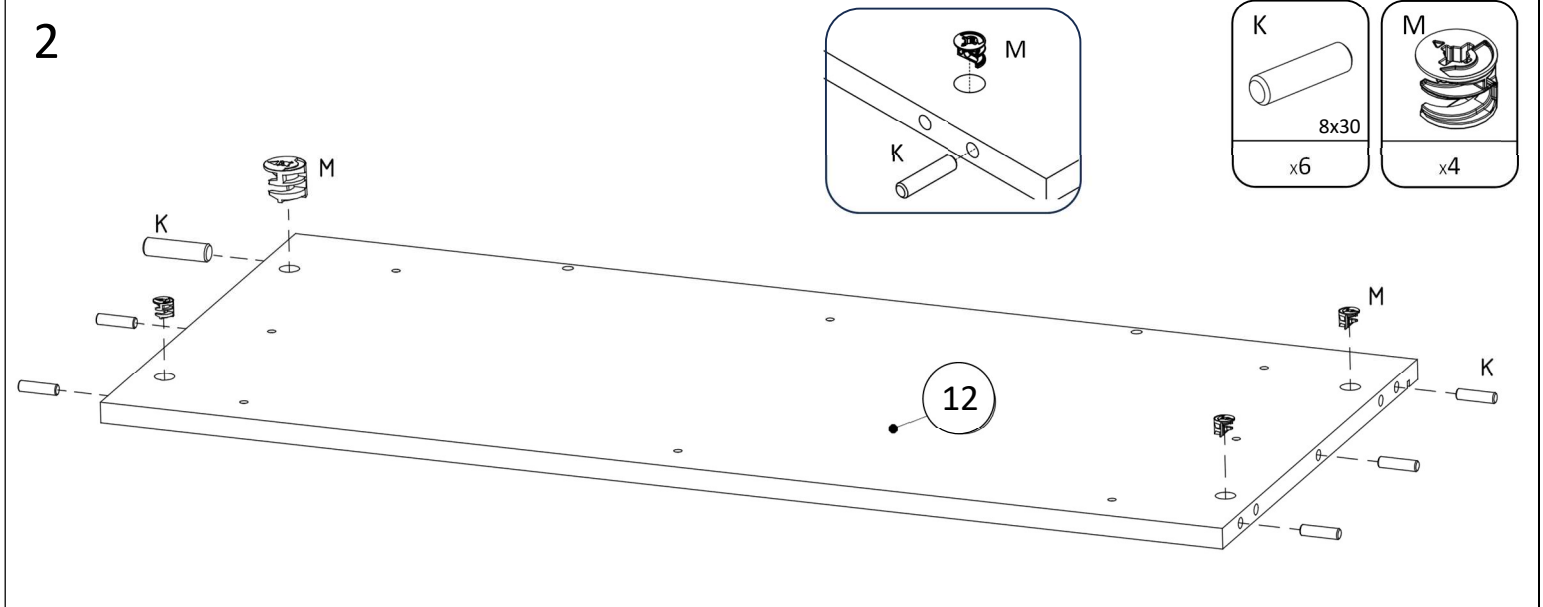
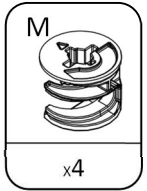
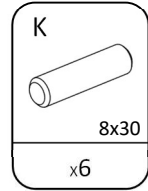
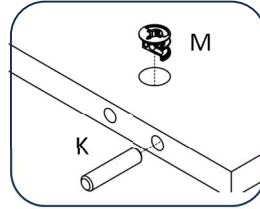

3

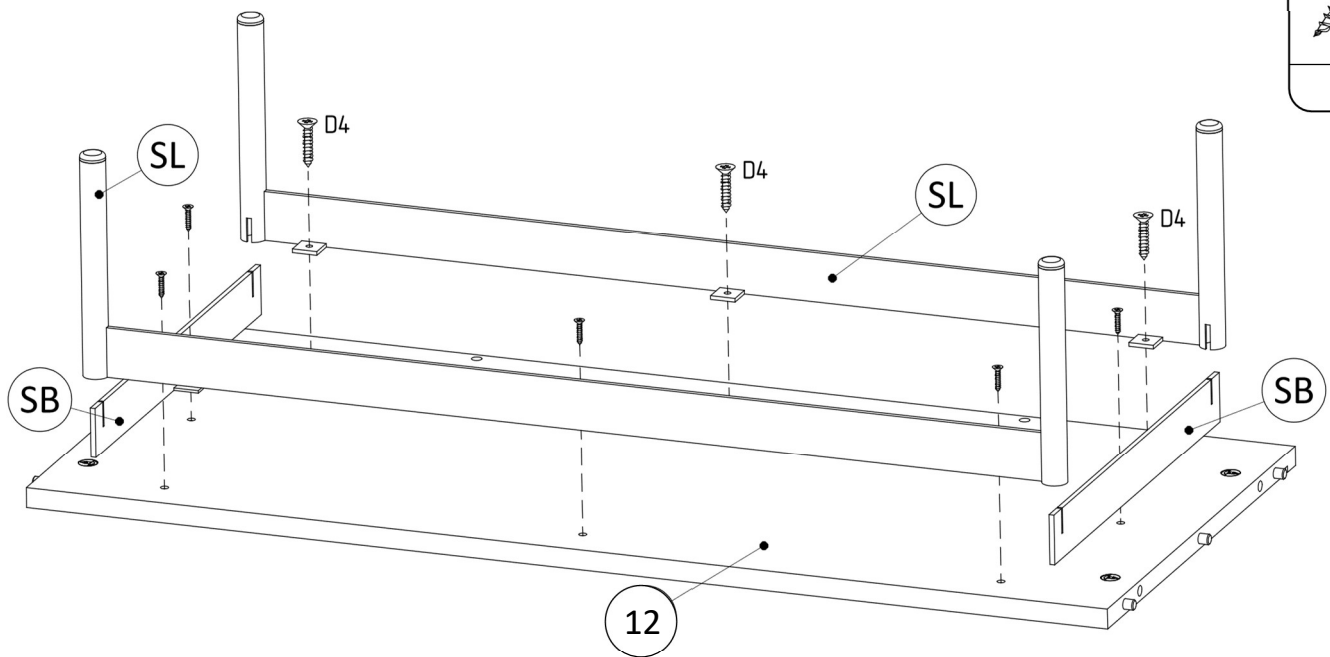
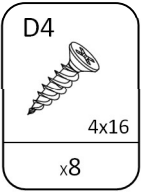

4

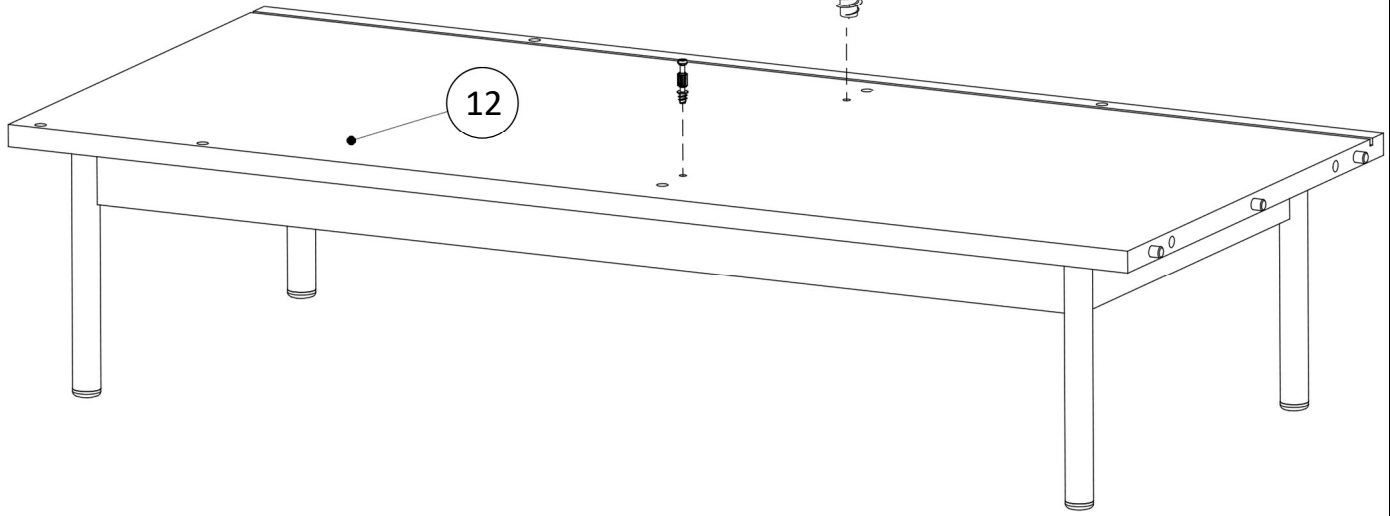
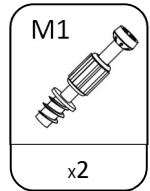
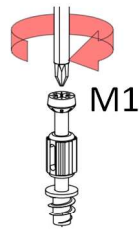
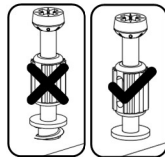

5

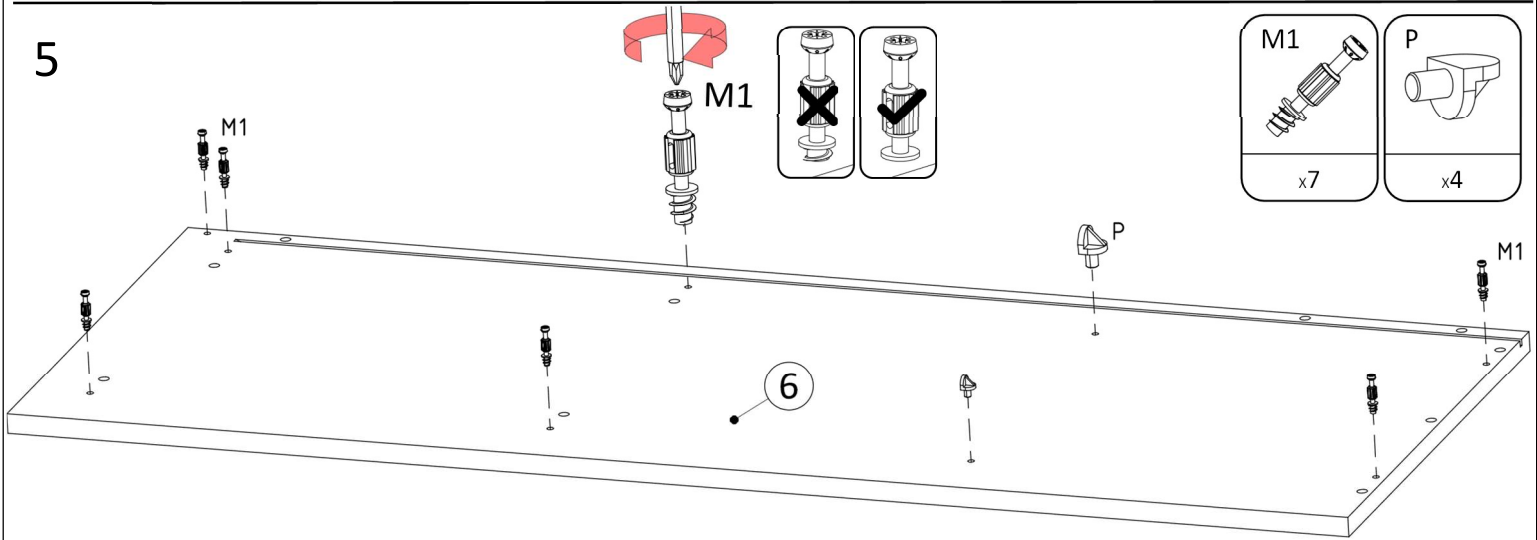
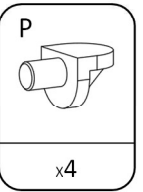
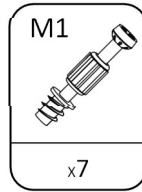
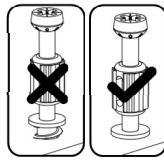
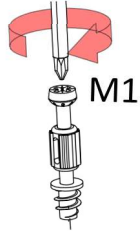

6

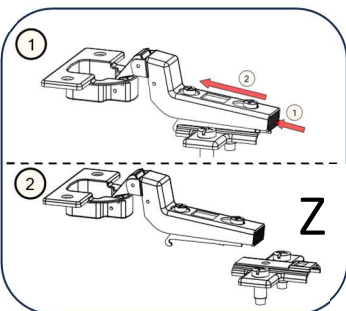
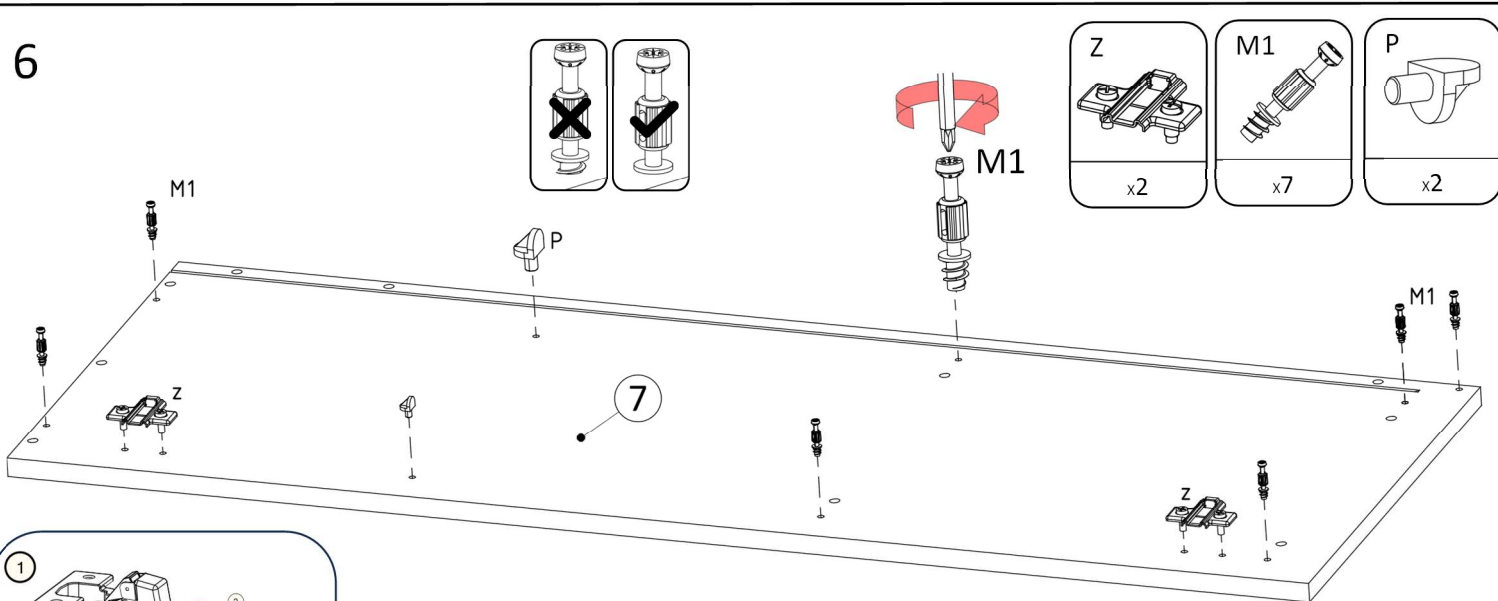
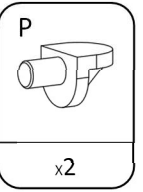
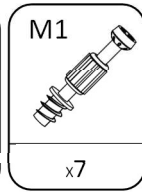
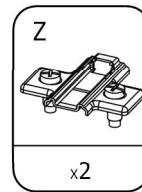
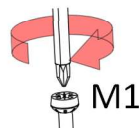
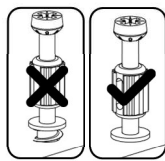

7

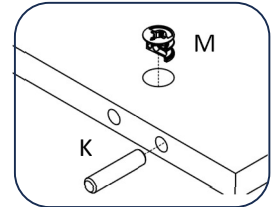
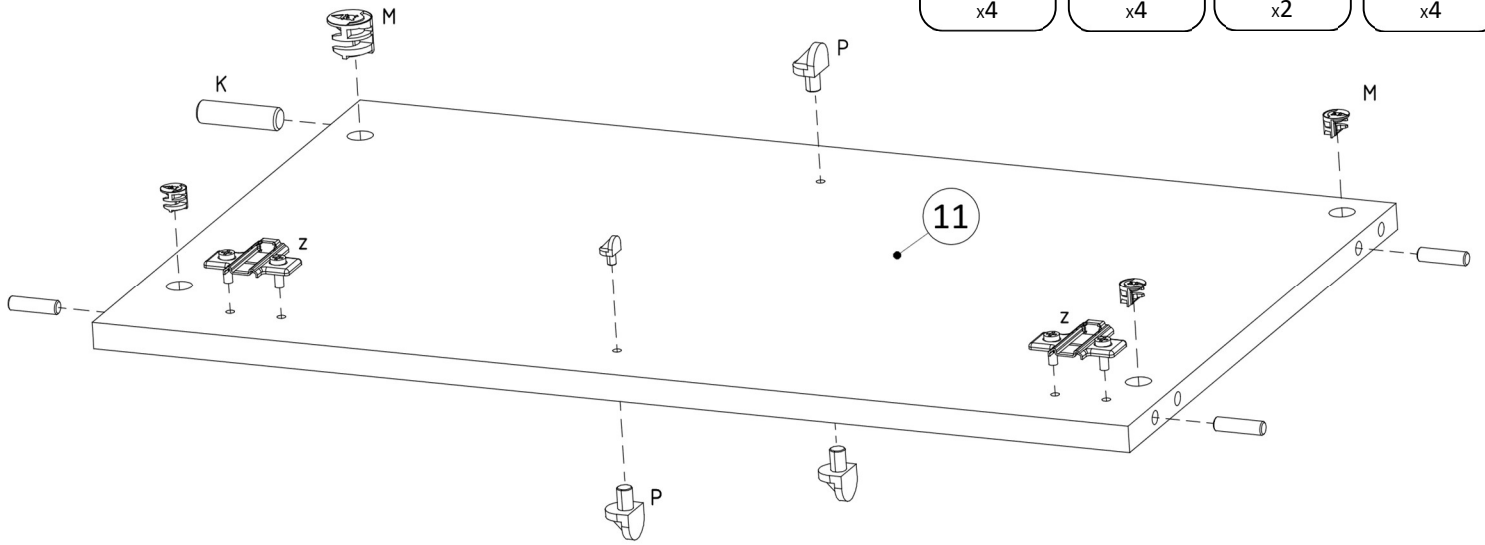
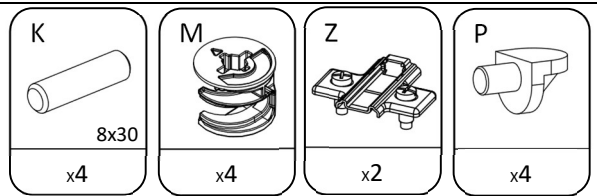

8

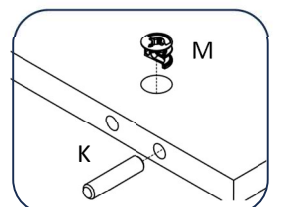
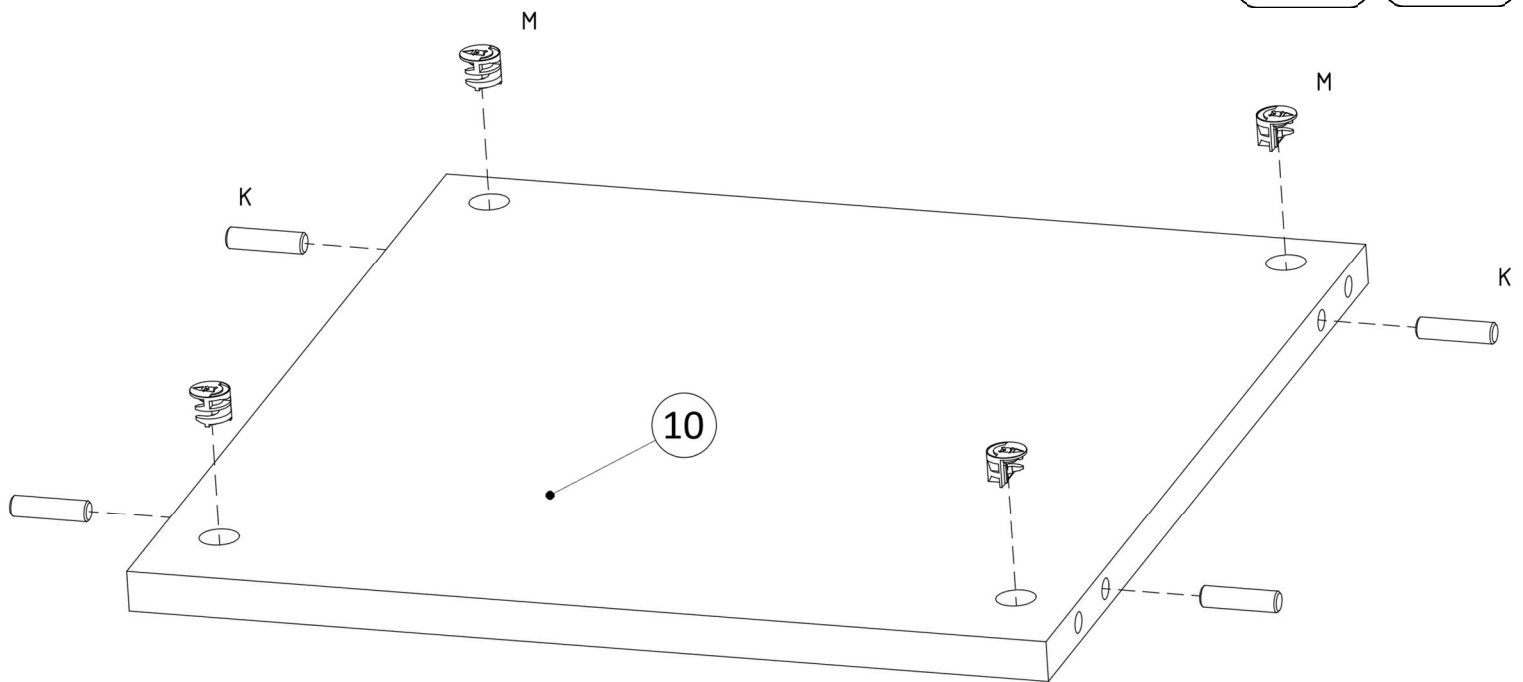
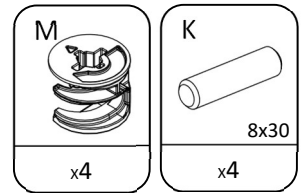

9

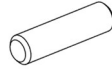
M	K
	
x2	8x30 x6

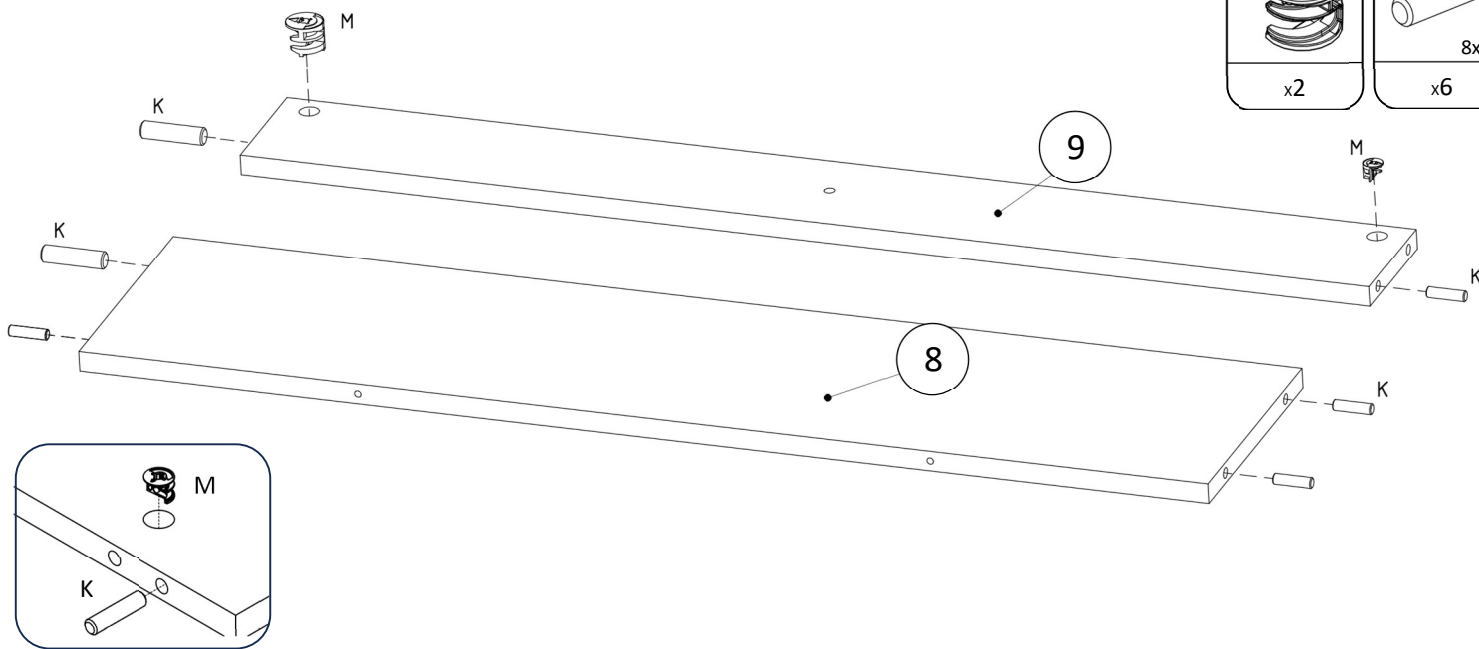



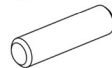

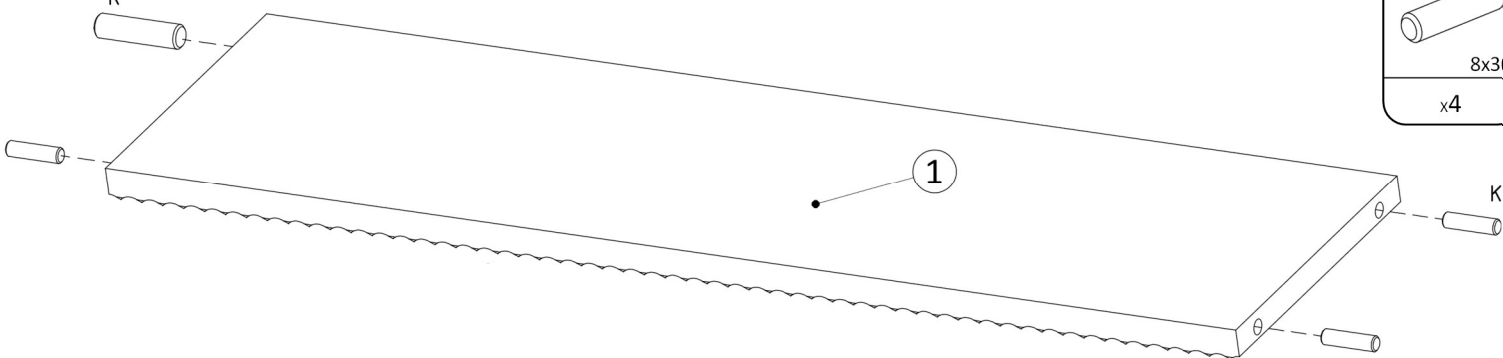
10

K

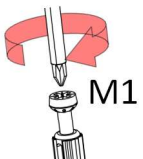
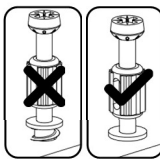
8x30 x4



11

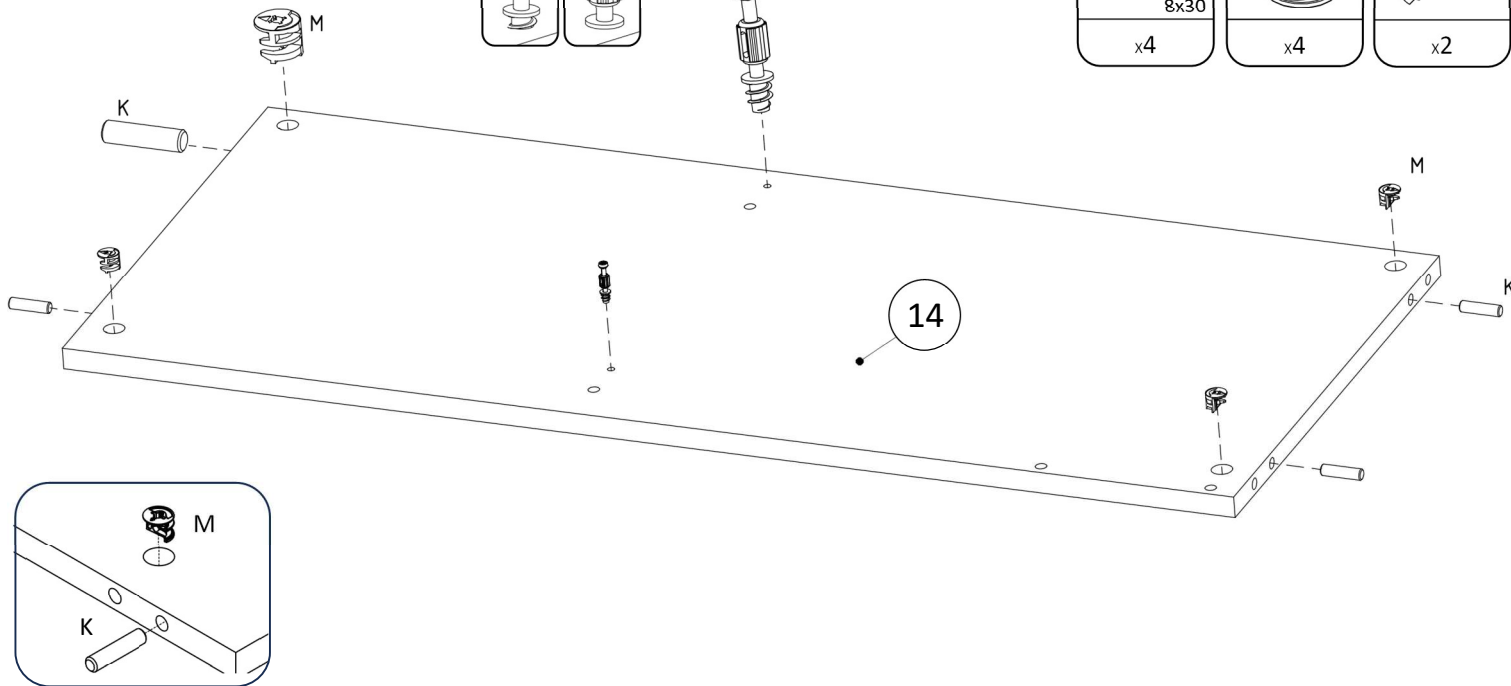

K	M	M1
		
8x30 x4	x4	x2



12

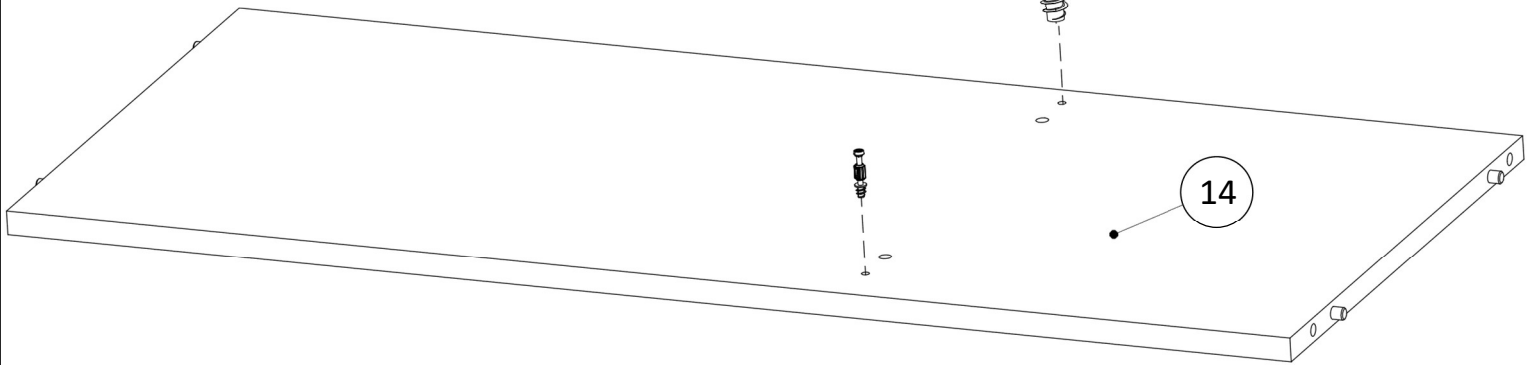
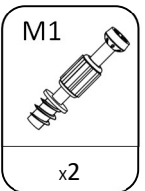
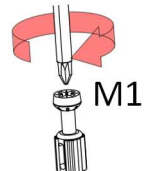
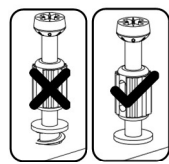

13

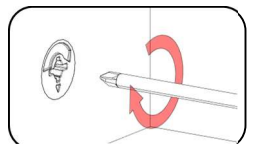
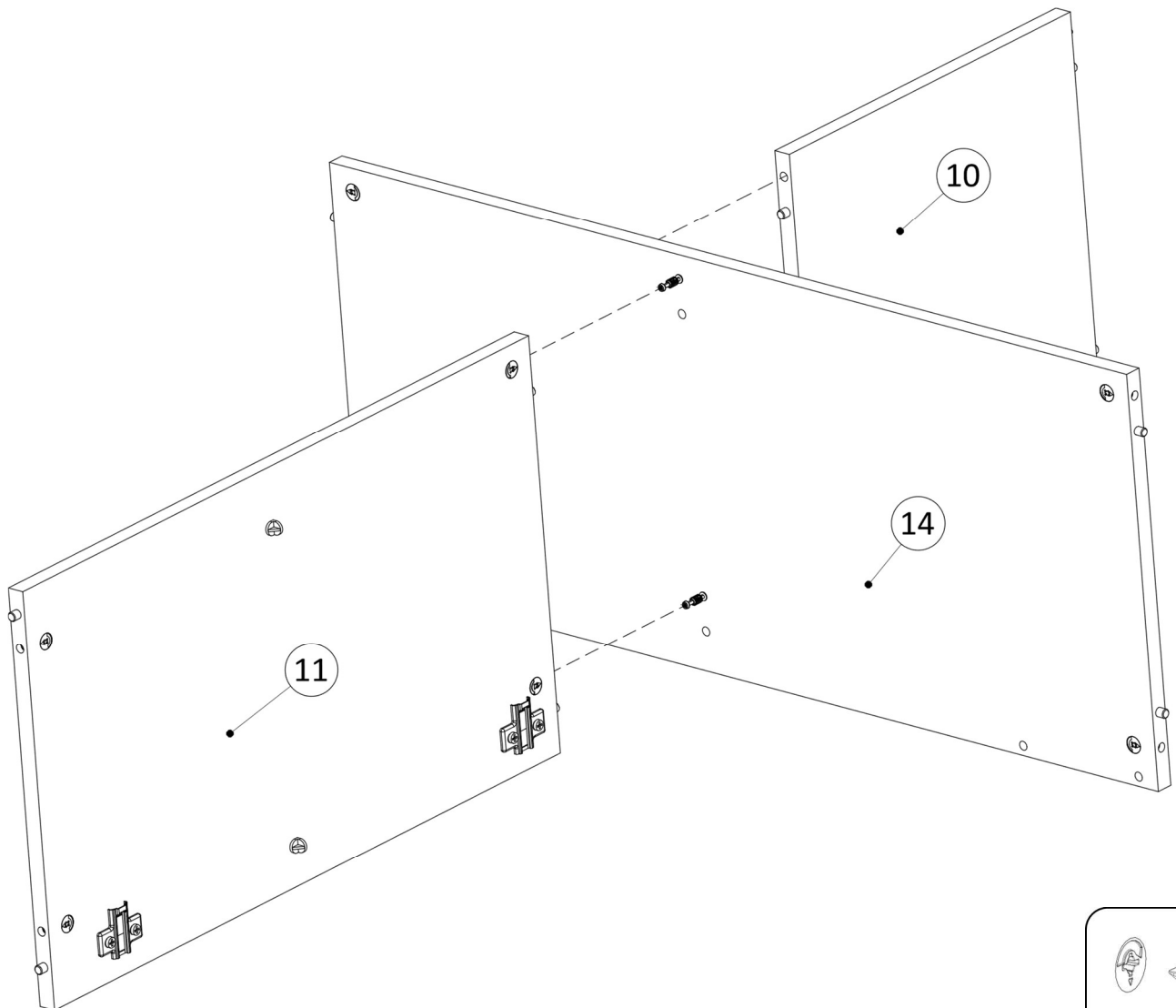

14

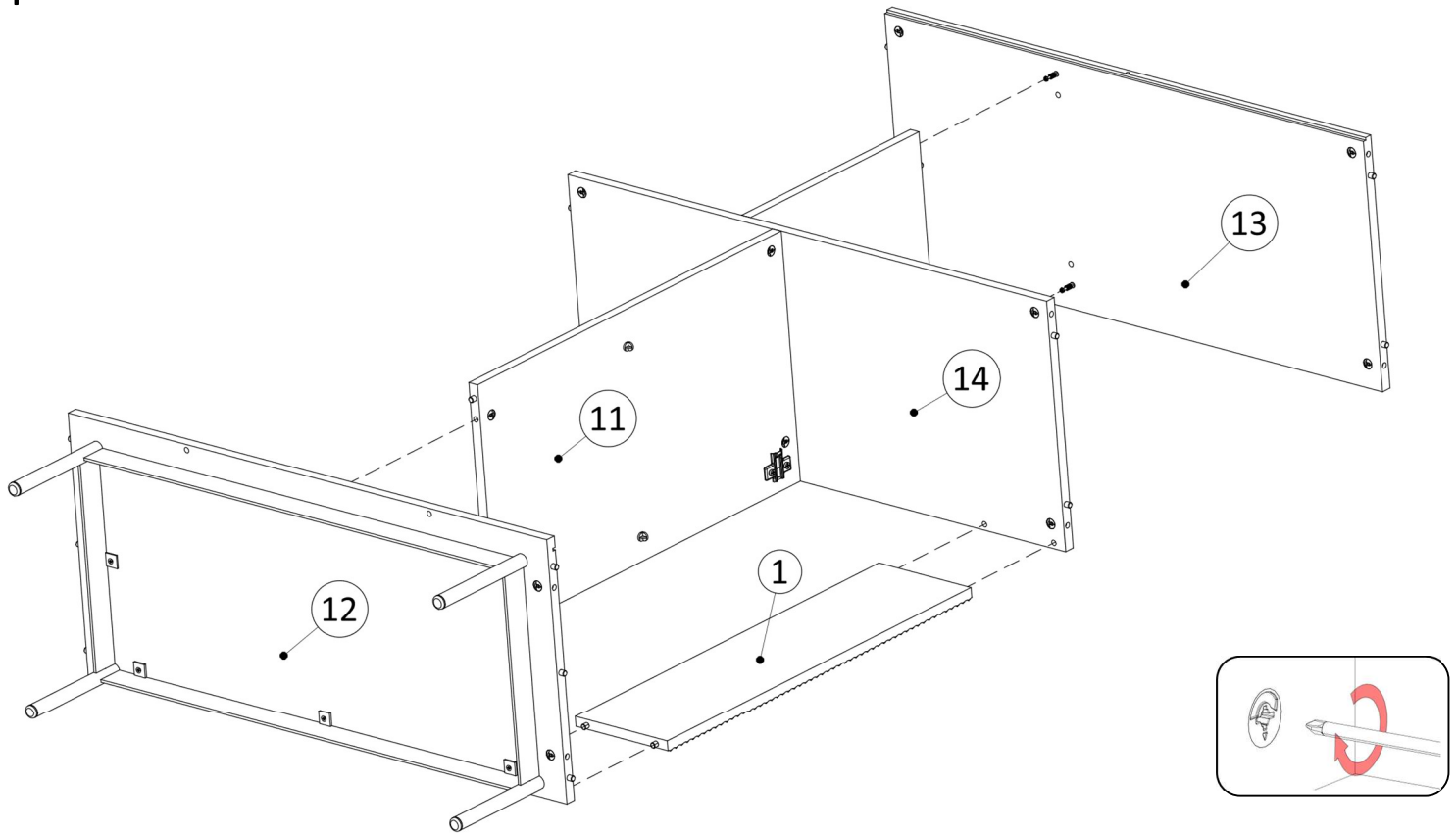

15

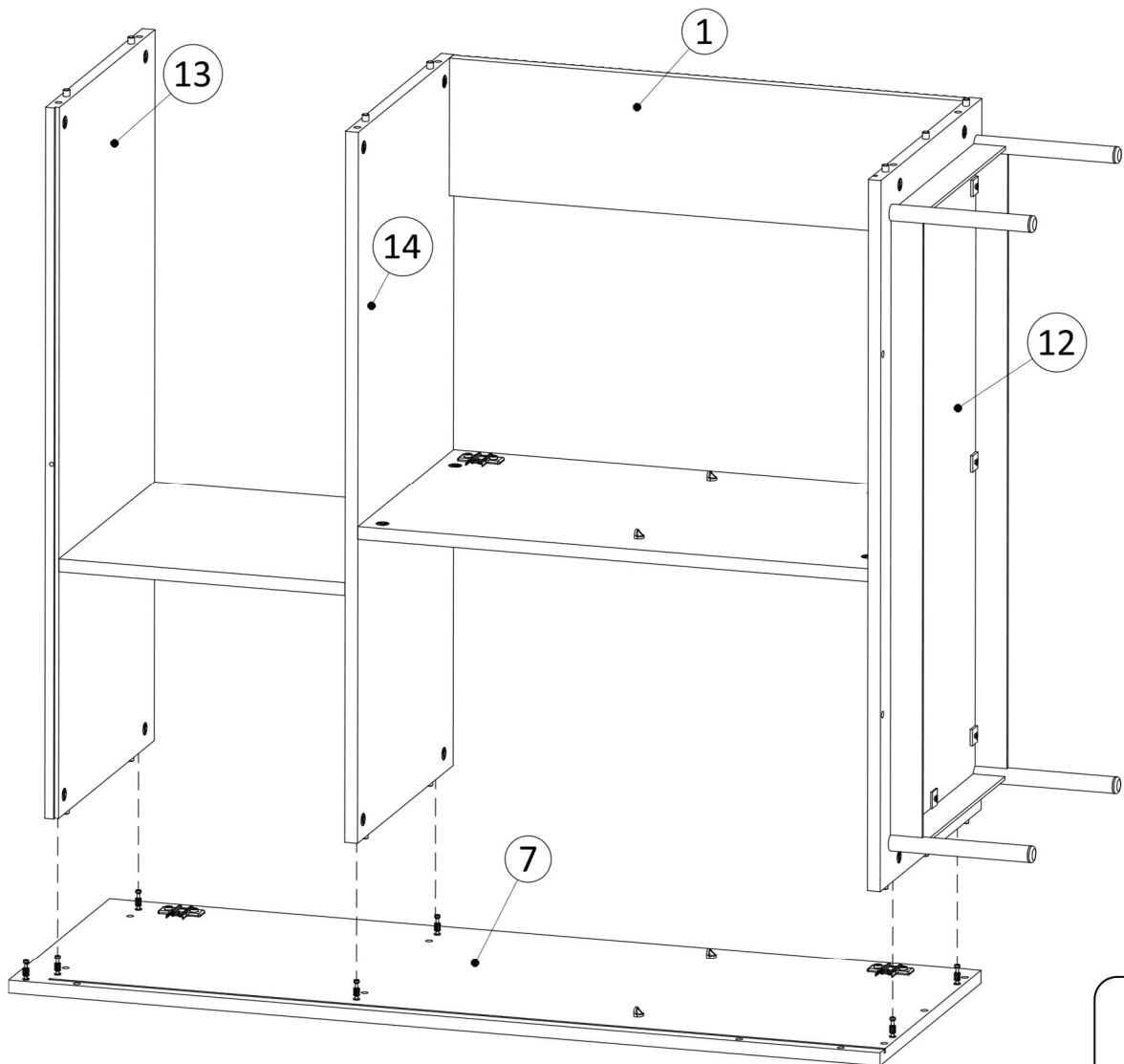

16

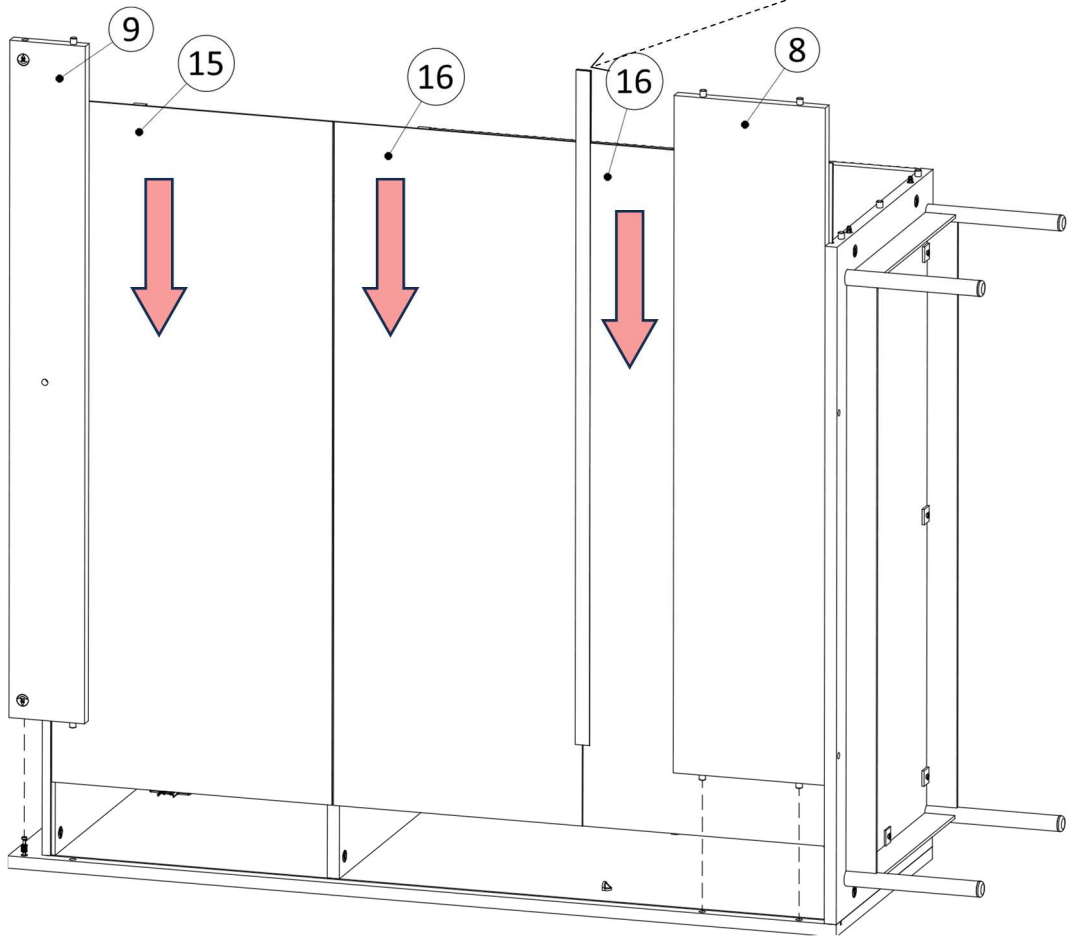

17

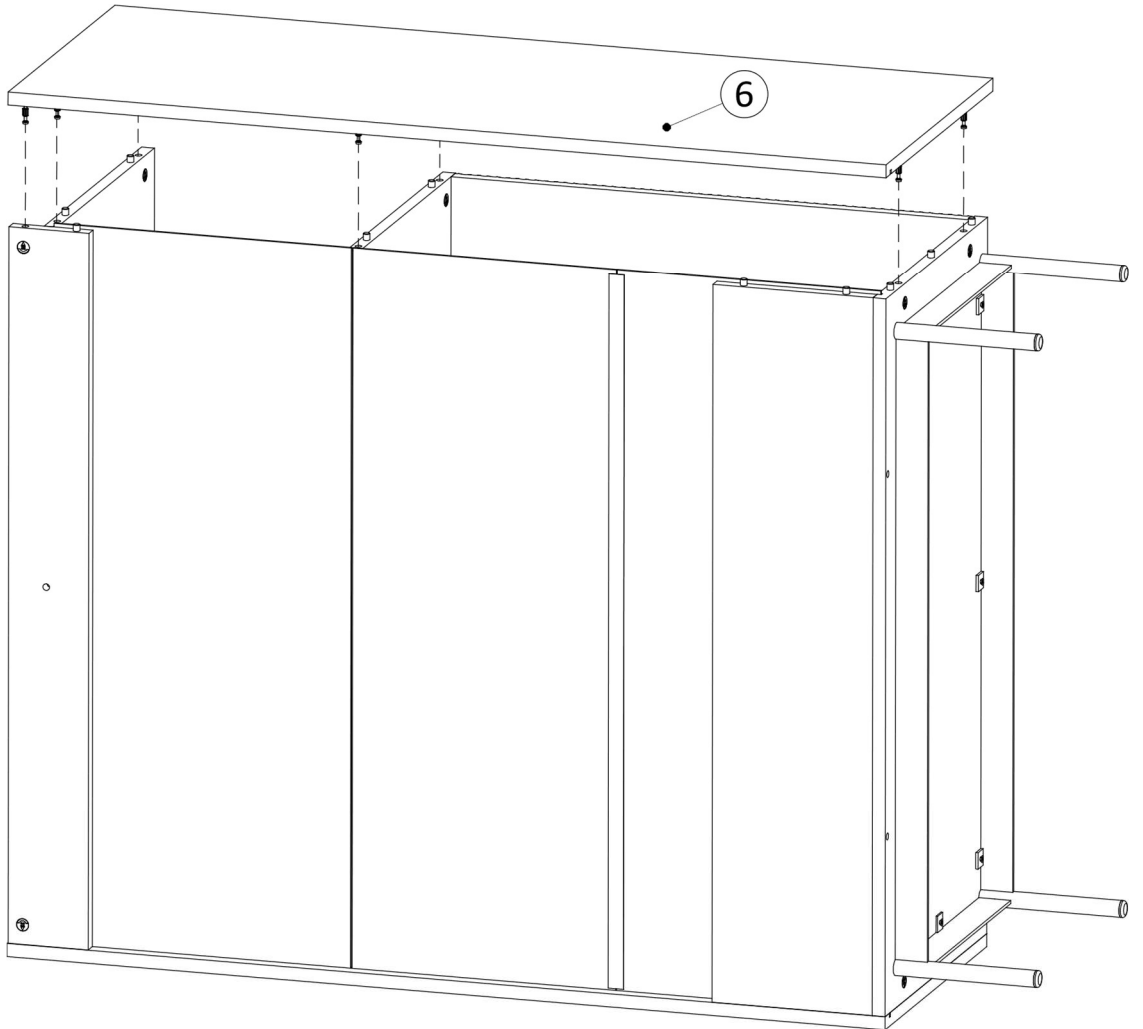

18

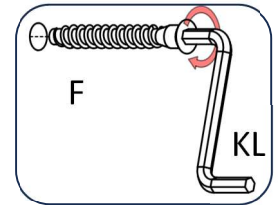
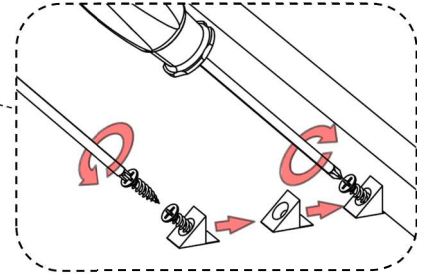
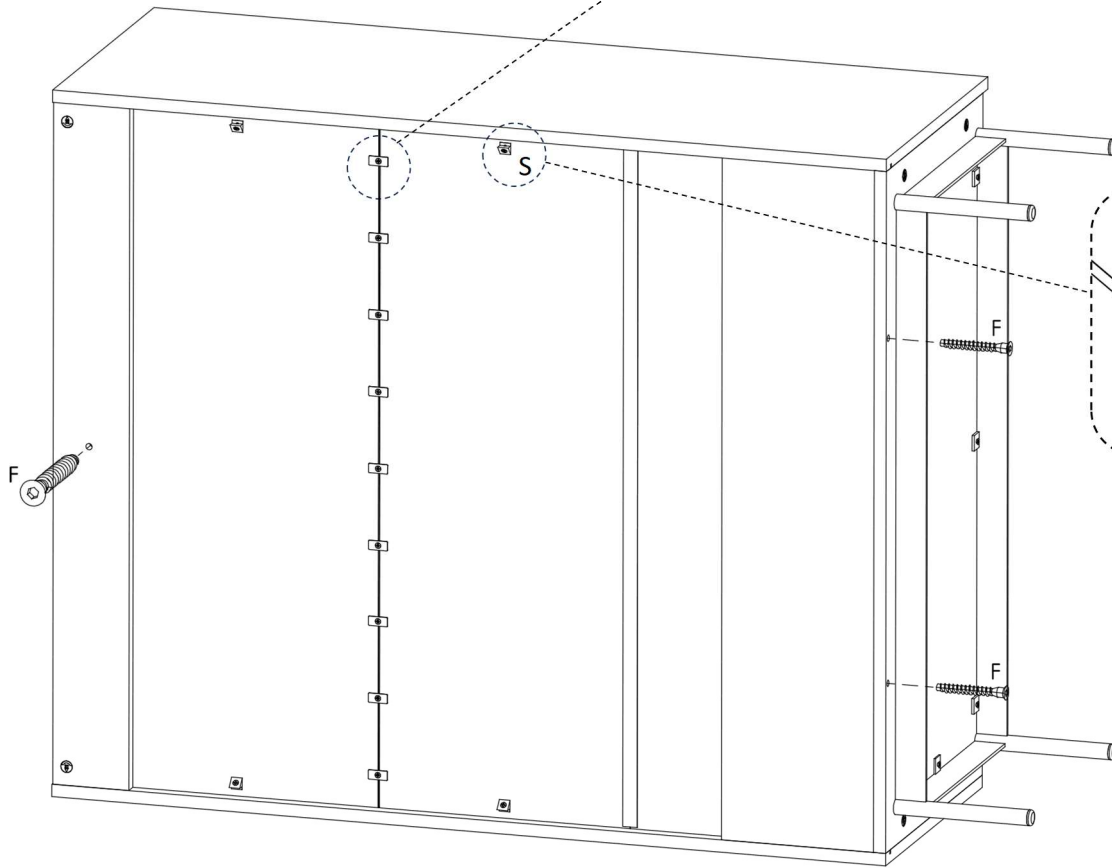
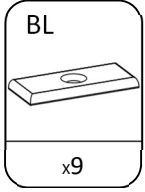
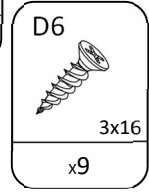
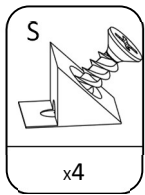
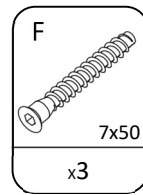
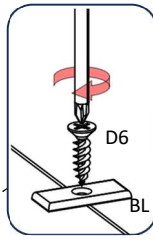
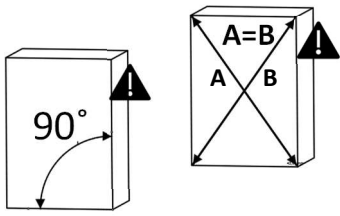

19

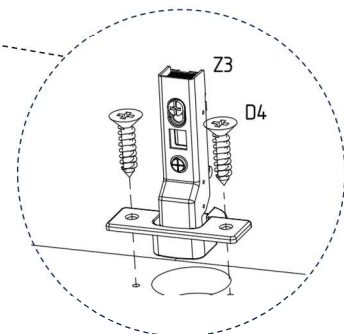
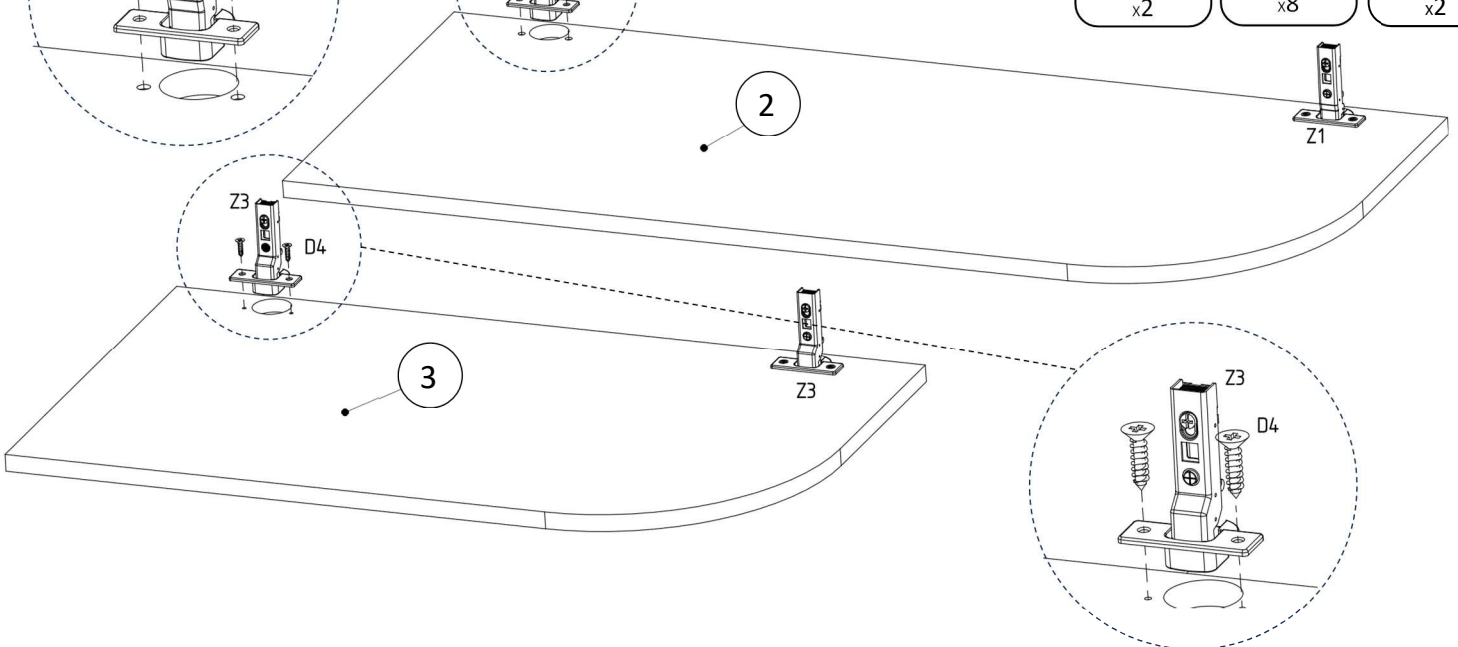
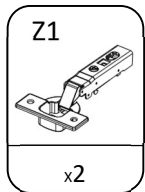
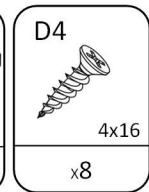
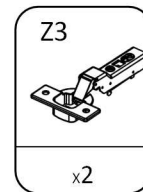
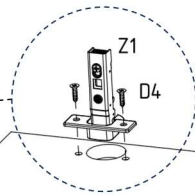
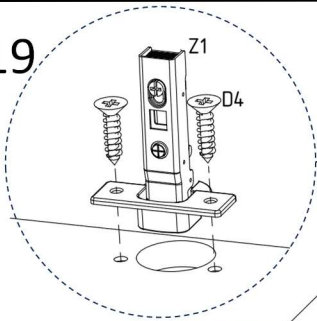

20

