

CARMEN

R-2

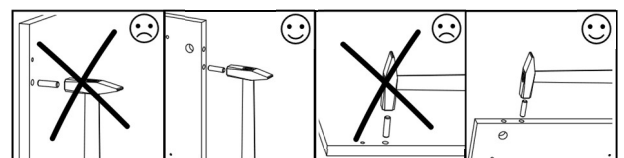

No.	T(mm)	L(mm)	W(mm)	pcs.
1	18	648	170	1
2	16	397	237	3
3	16	762	497	1
4	16	716	397	1
5	16	490	354	1
6	16	453	374	1
7	16	415	374	1
8	16	320	140	3
9	16	1770	420	1
10	16	350	140	3
11	16	1770	400	1
12	16	884	200	1
13	16	378	100	1
14	16	884	100	1
15	16	648	379	1
16	16	654	379	1
17	16	884	400	1
18	16	884	383	1
19	16	884	379	1
20	16	884	379	1
21	16	350	140	3
22	3	333	346	3
23	3	892	331	1
24	3	892	329	3
25	3	892	378	1

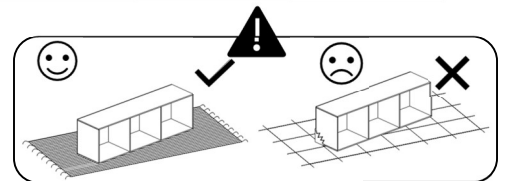
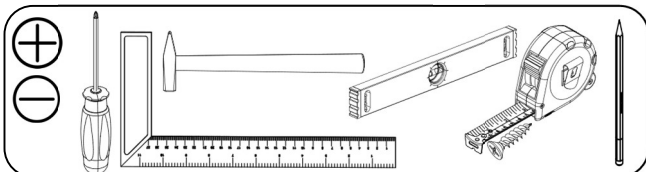
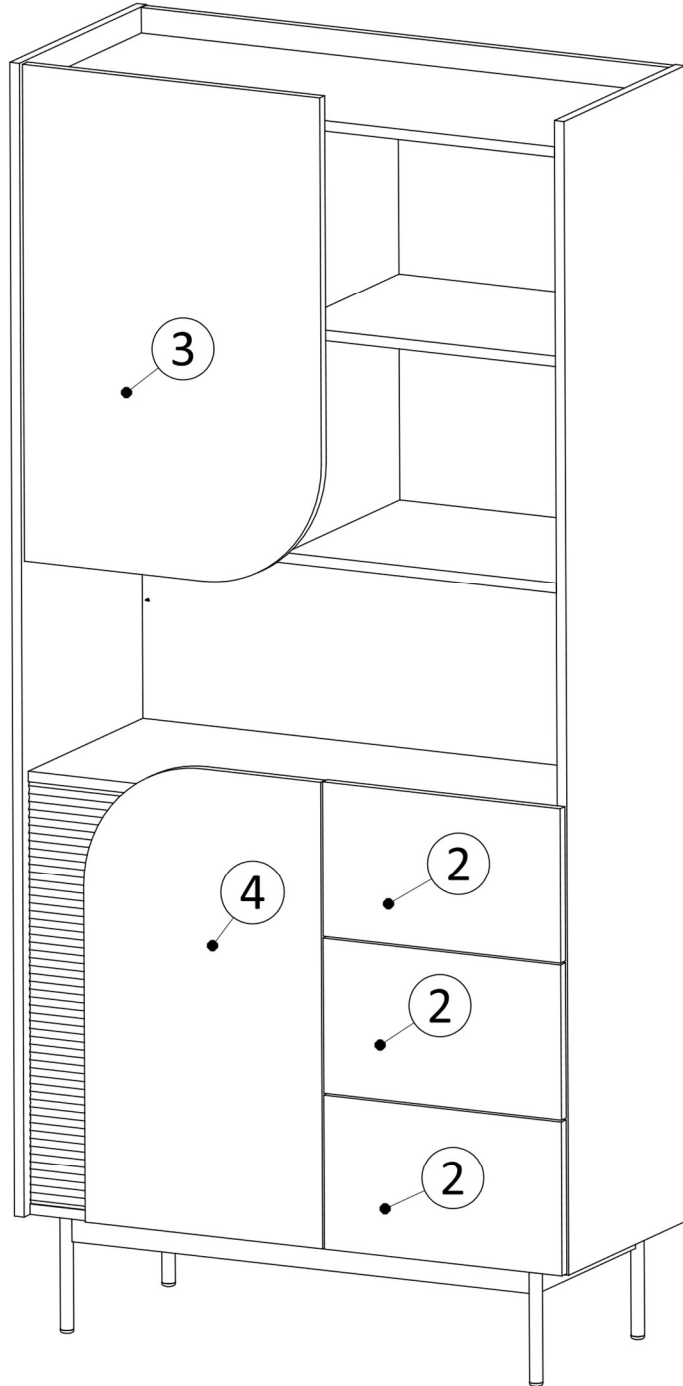
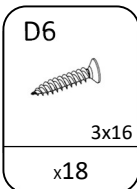
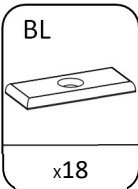
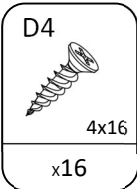
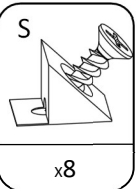
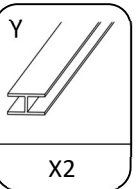
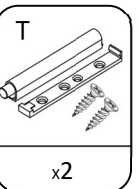
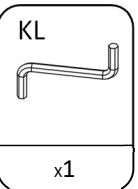
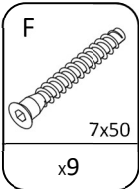
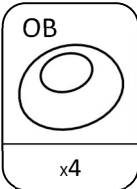
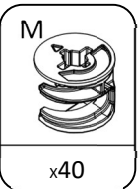
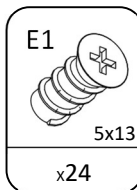
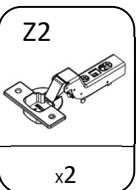
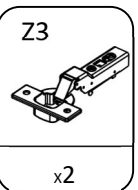
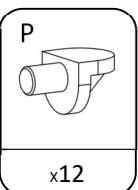
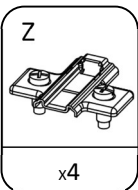
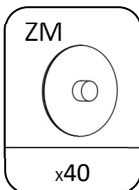
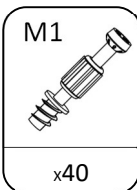
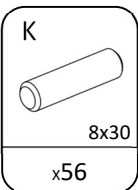
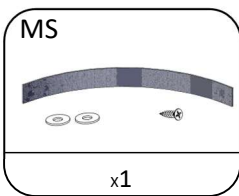
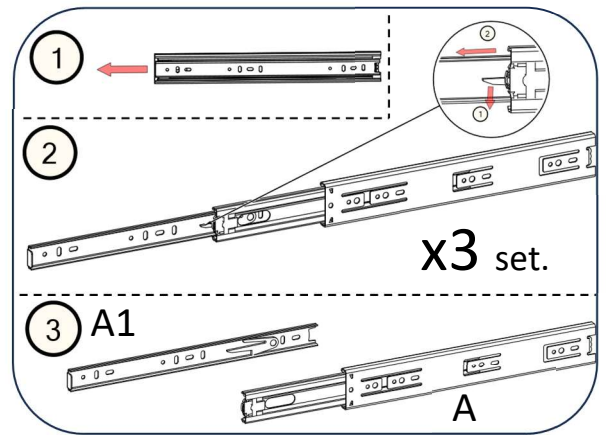
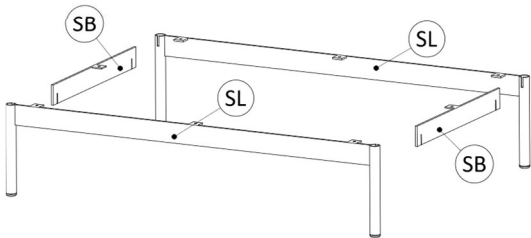
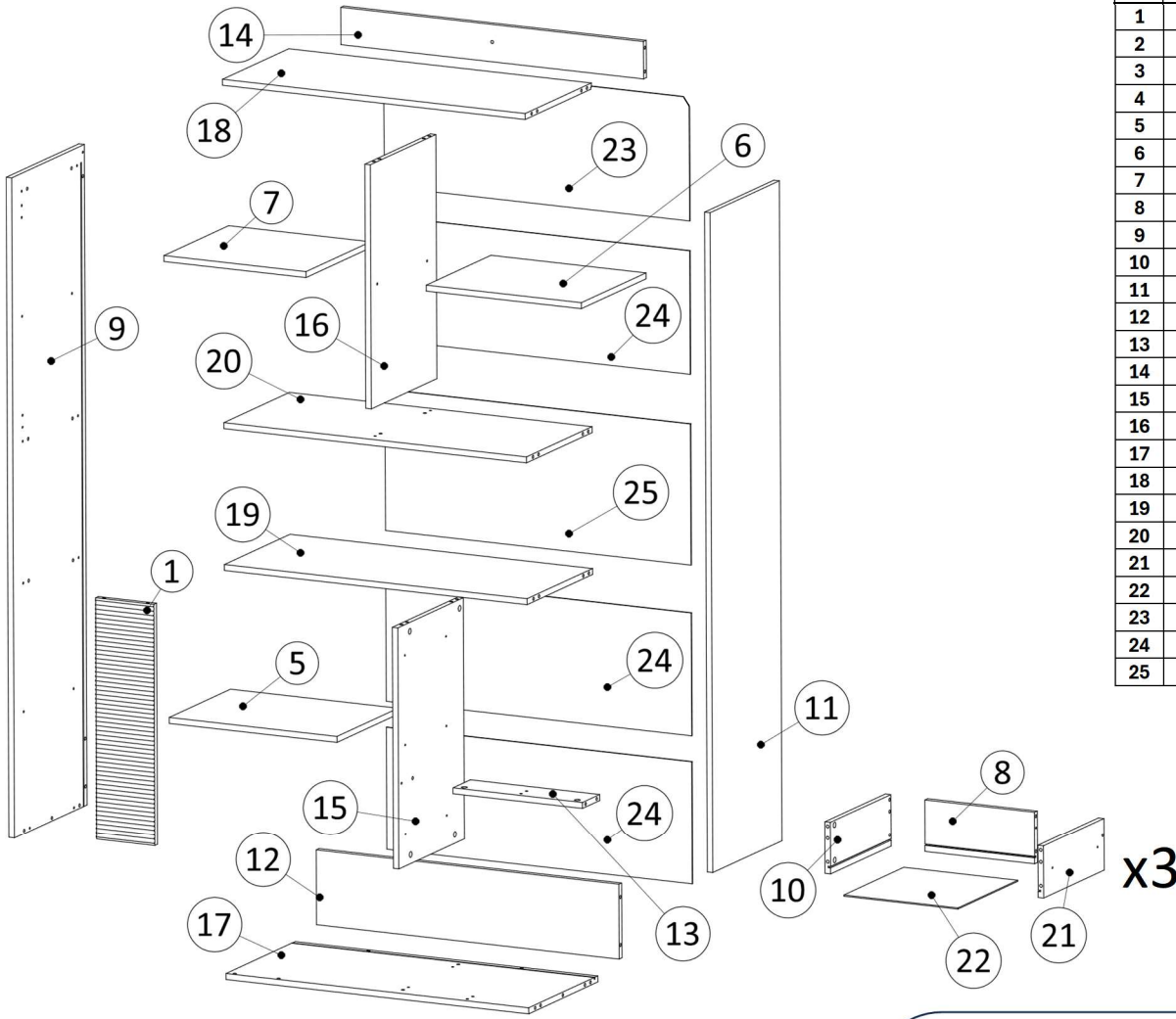

1

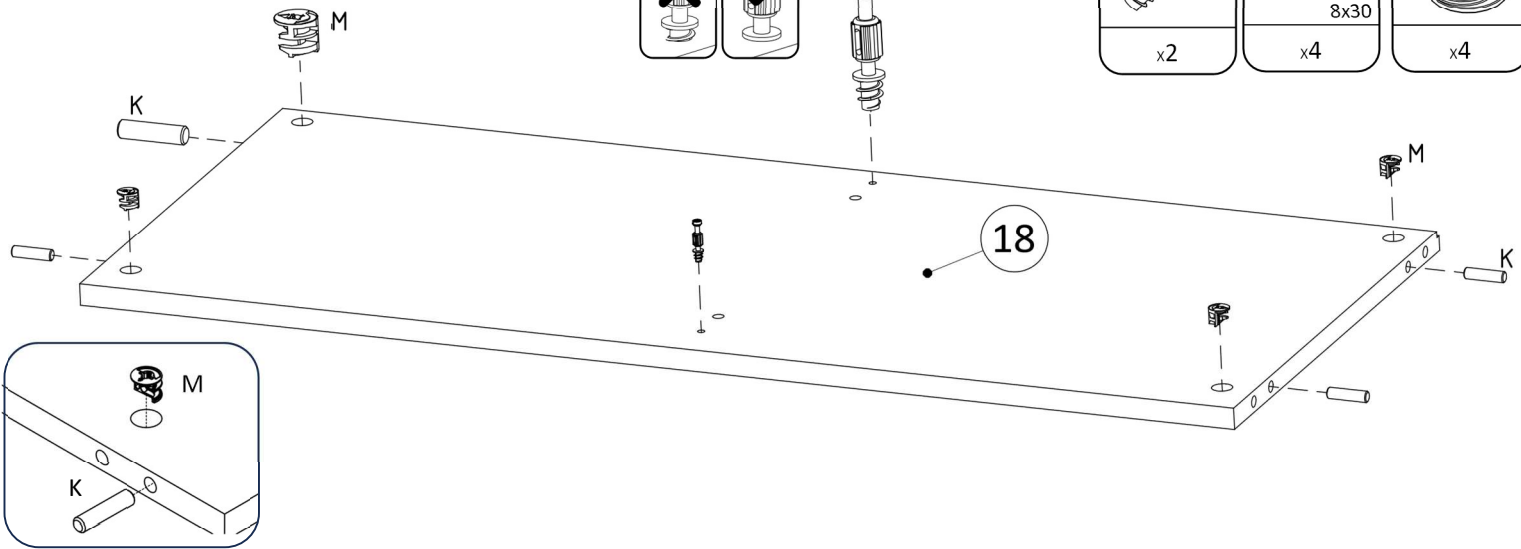
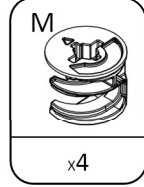
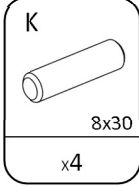
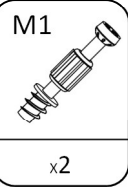
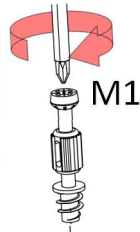
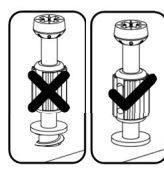

2

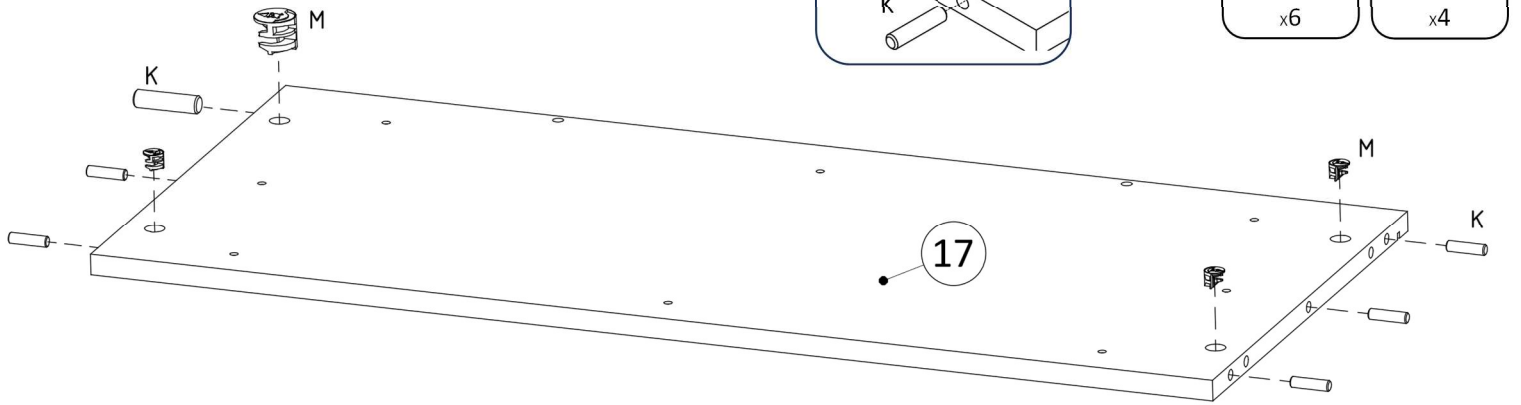
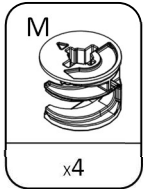
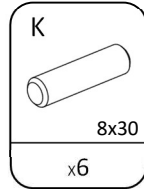
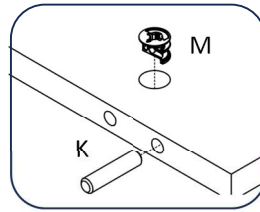

3

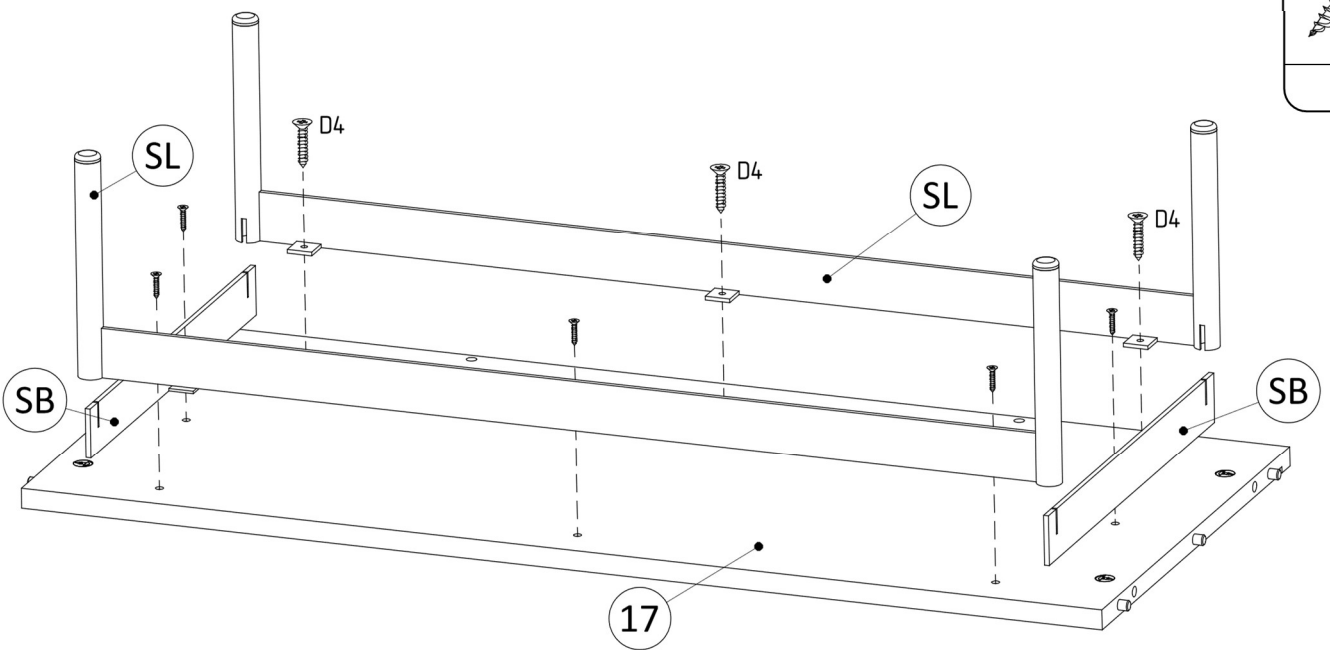
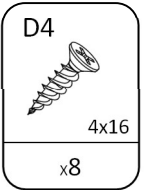

4

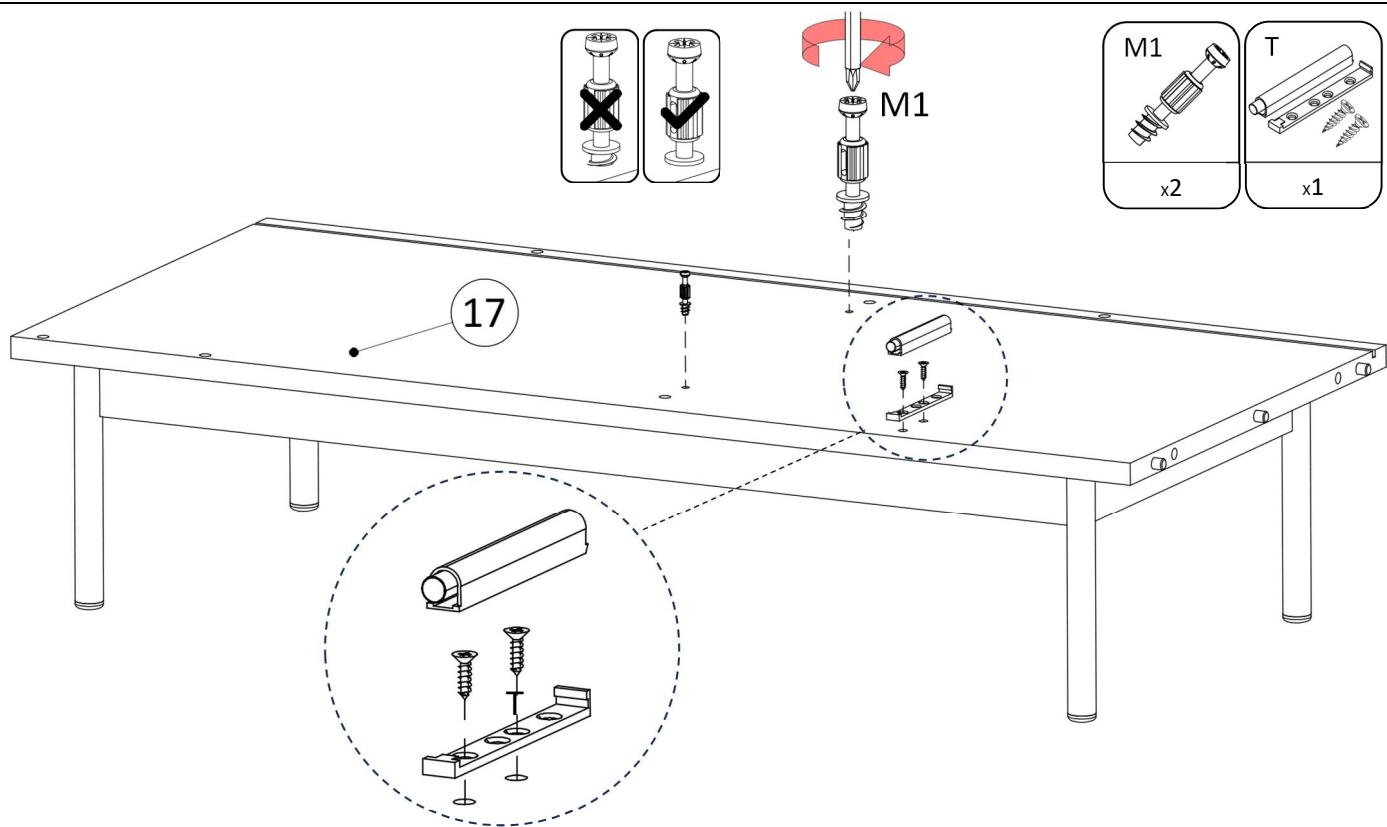

5

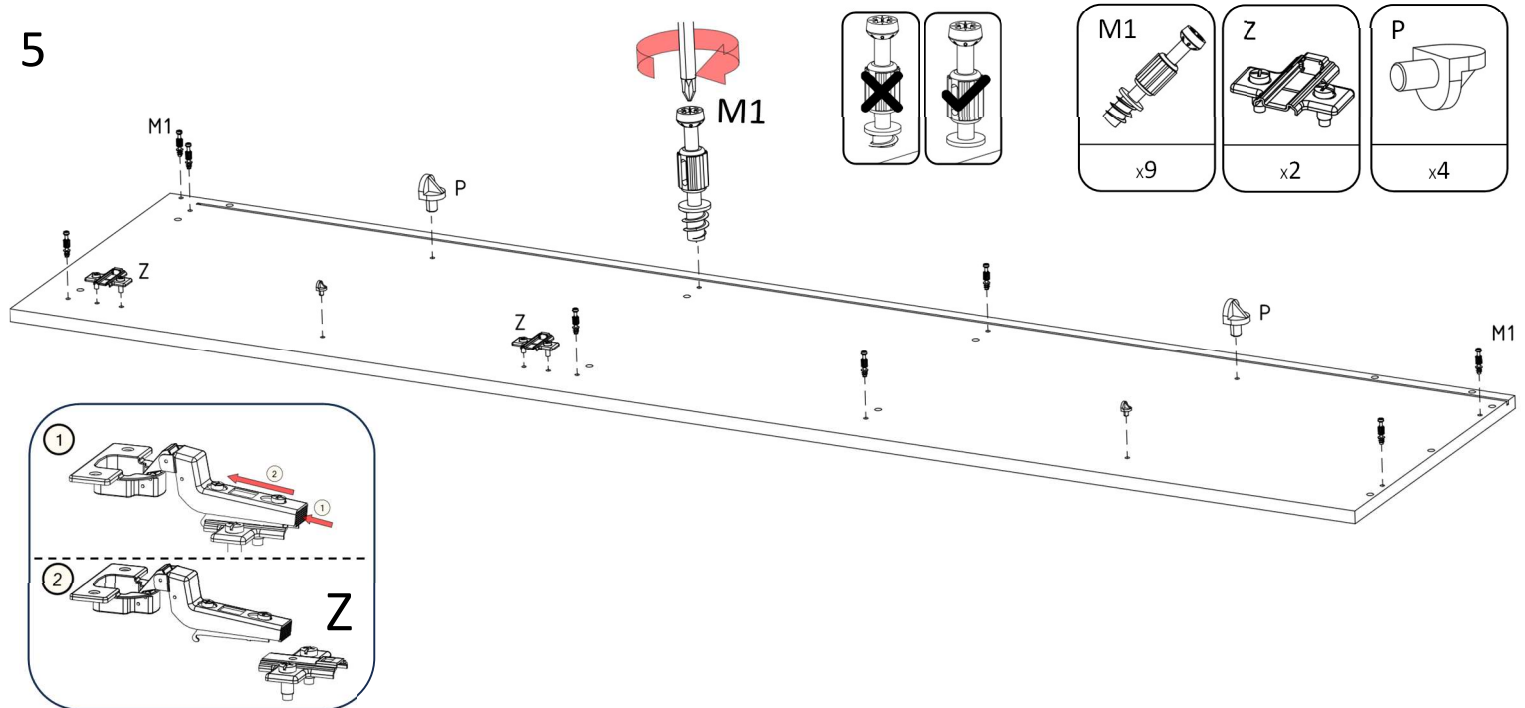

6

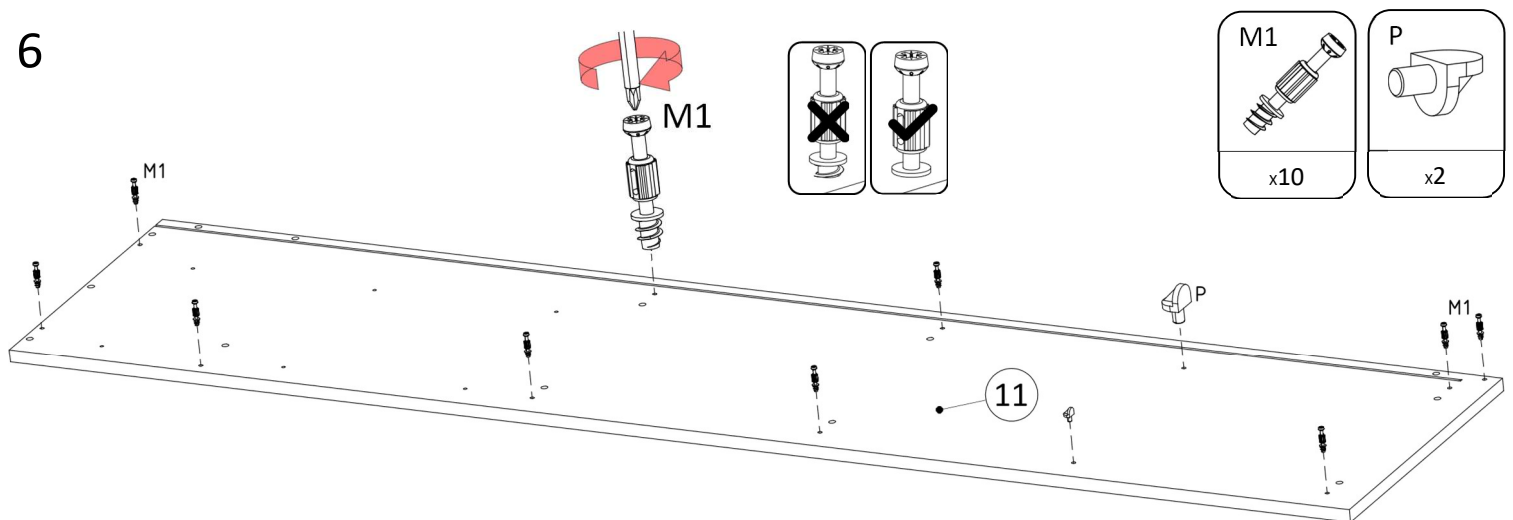

7

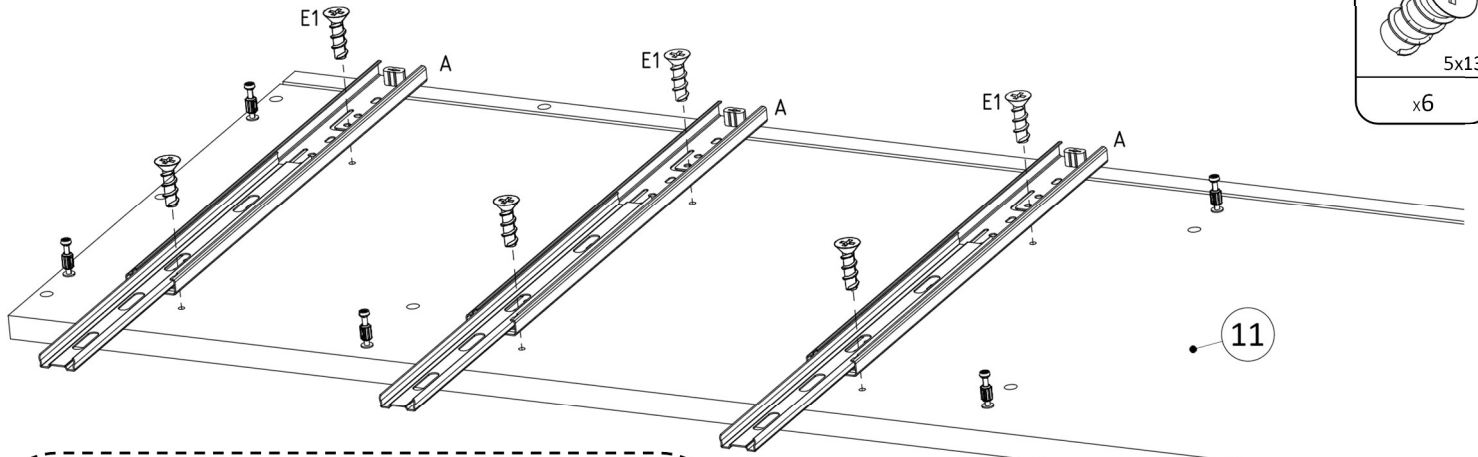

E1	
	5x13
x6	

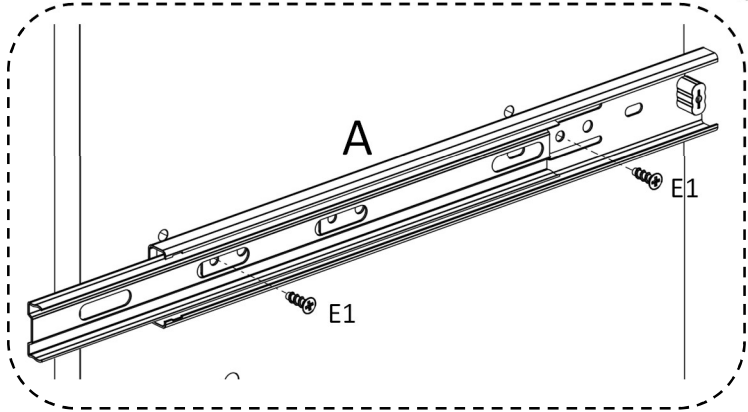

8

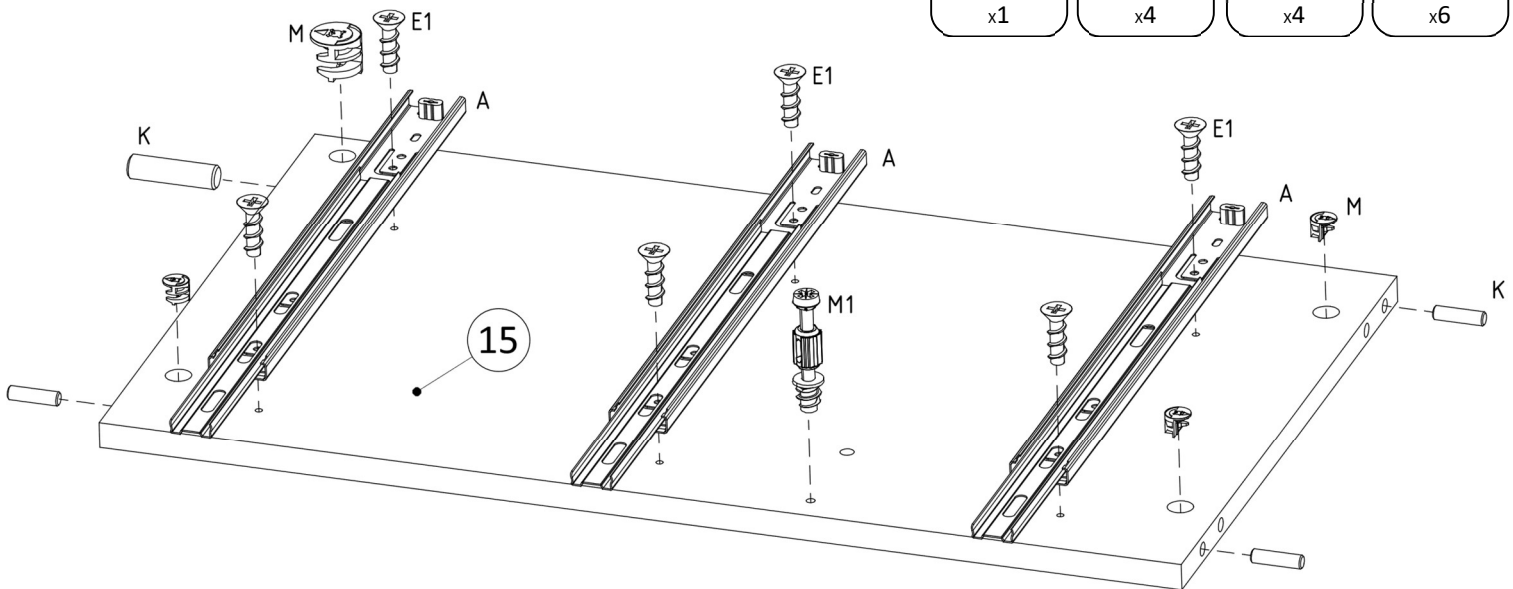

M1	
x1	

K	
8x30	
x4	

M	
x4	

E1	
5x13	
x6	

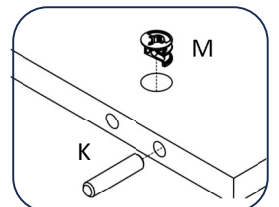
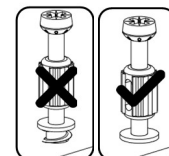
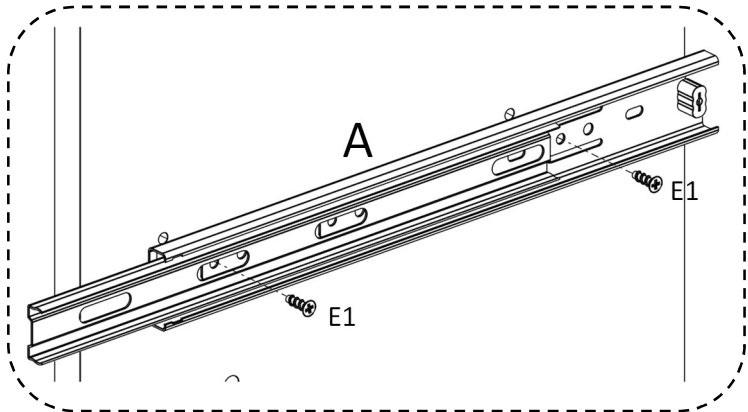

9

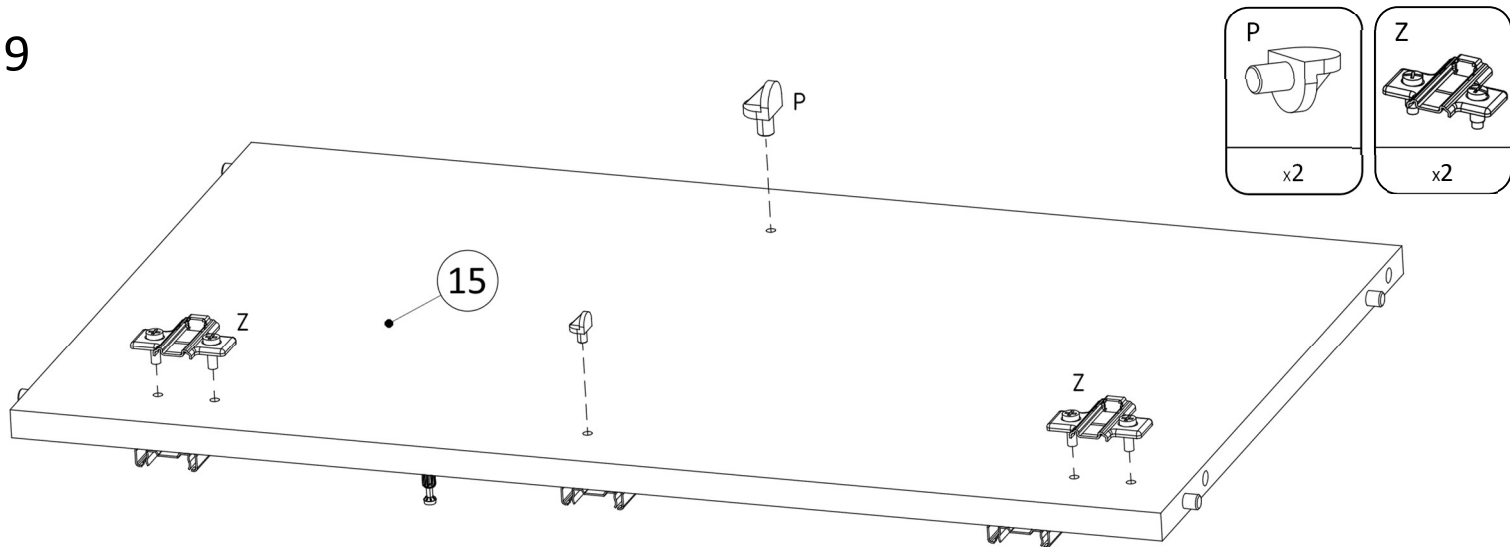

10

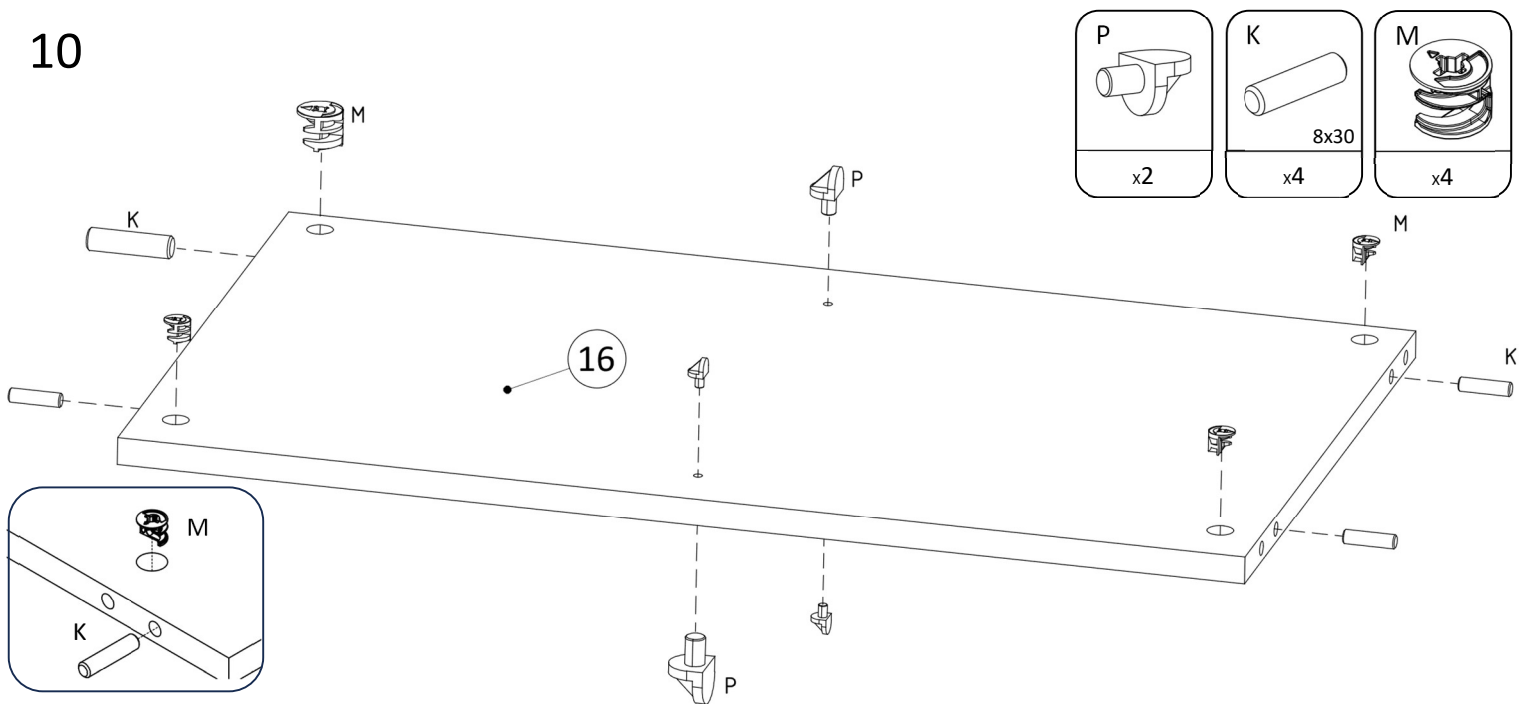

11

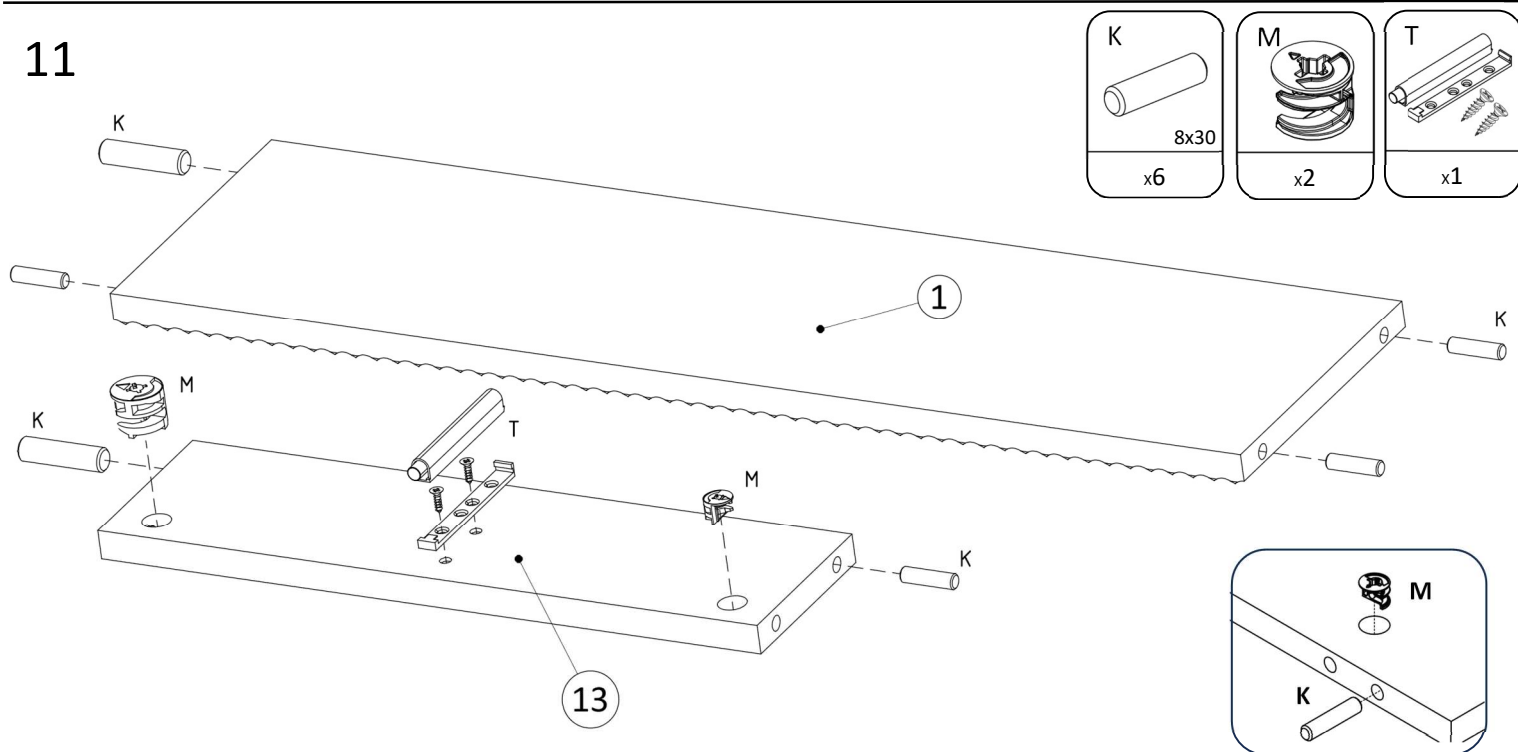

12

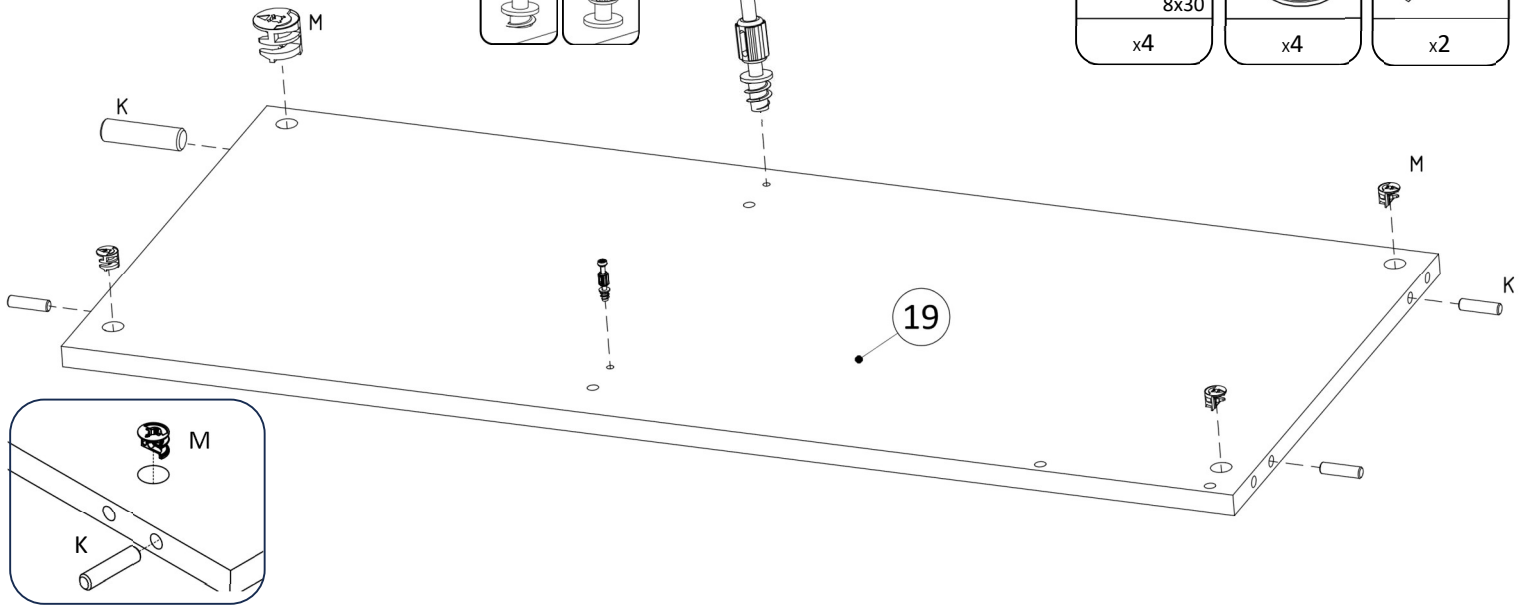
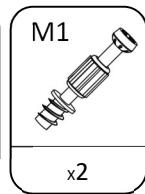
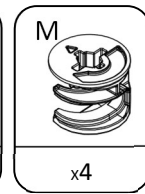
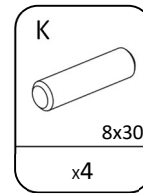
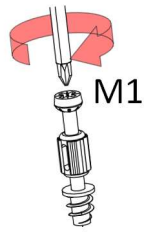
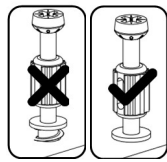

13

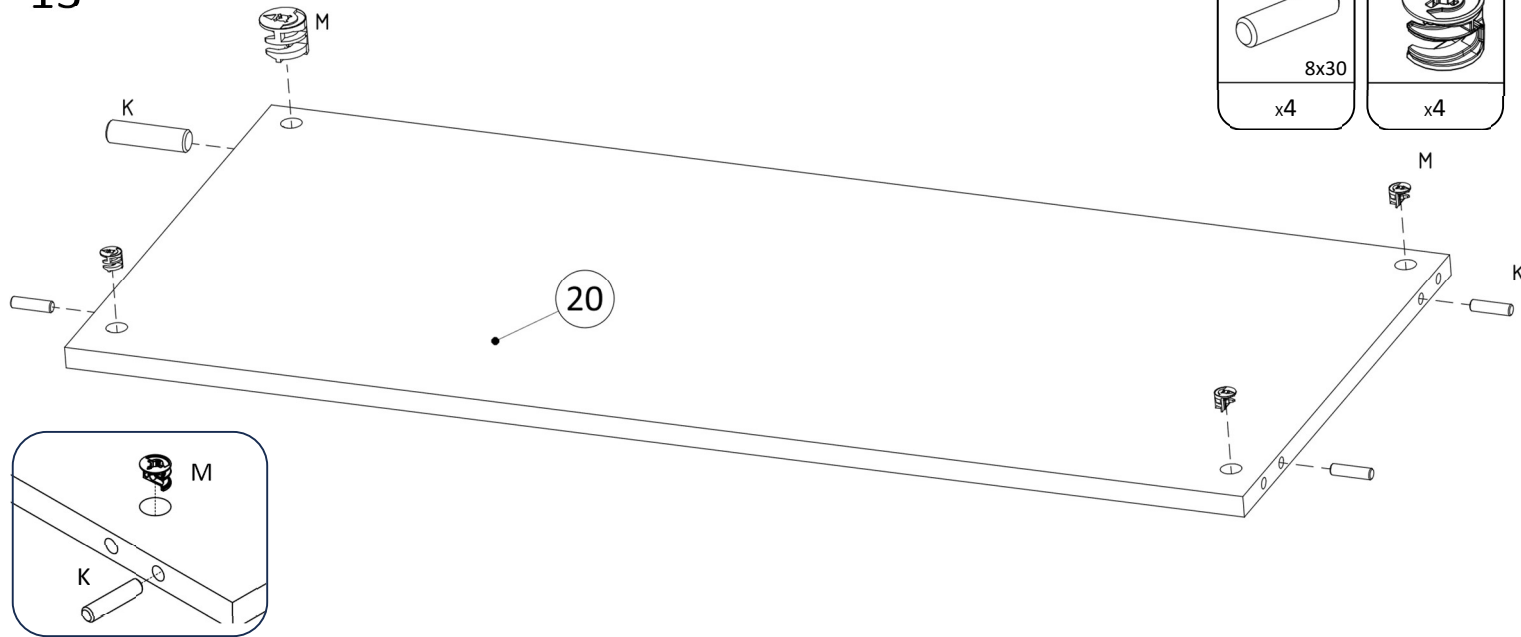
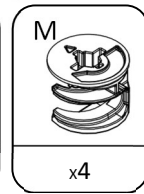
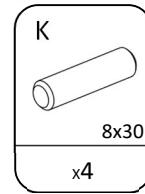

14

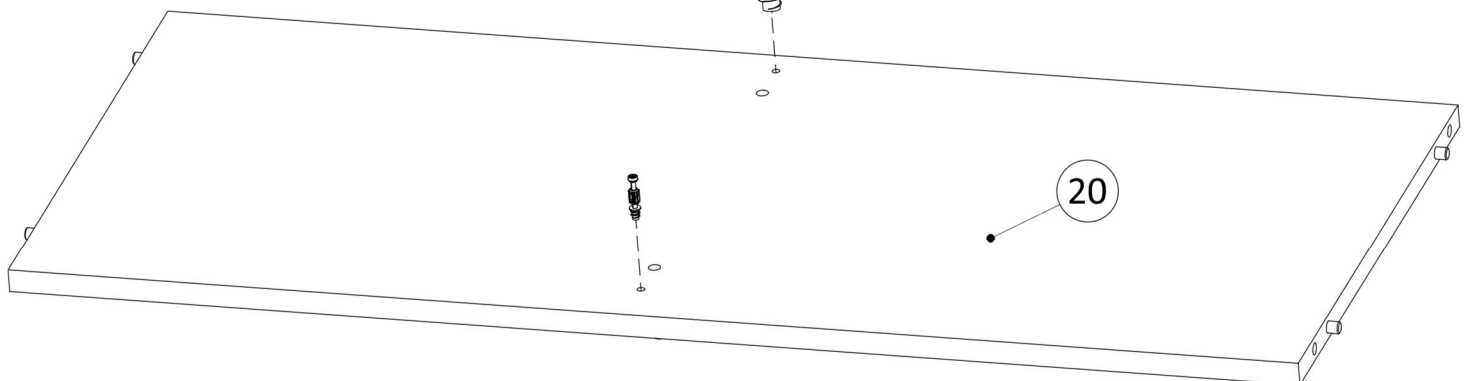
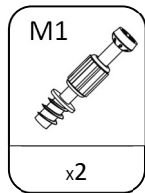
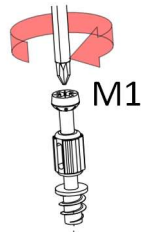
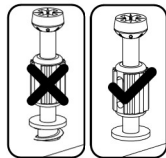

15

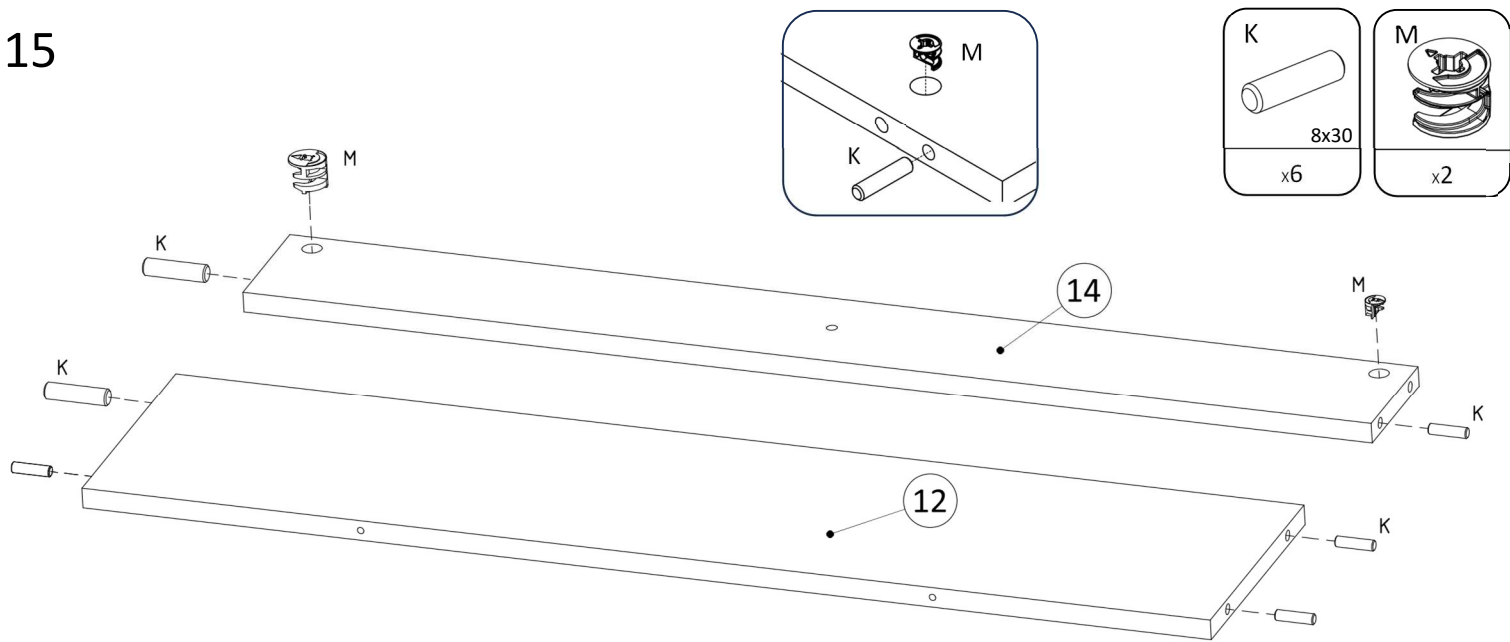

16

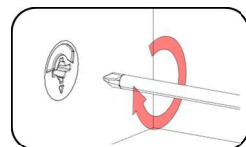
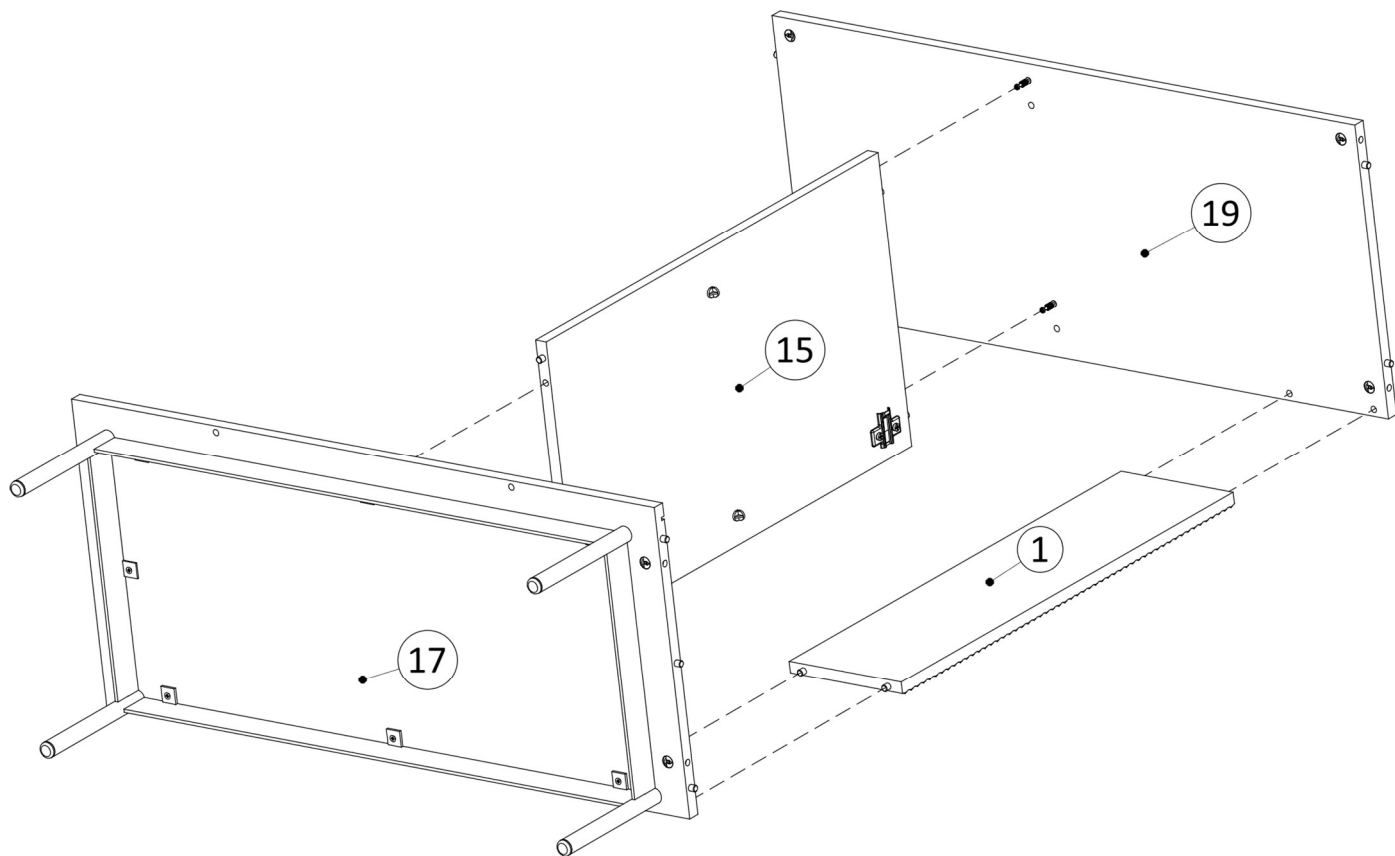

17

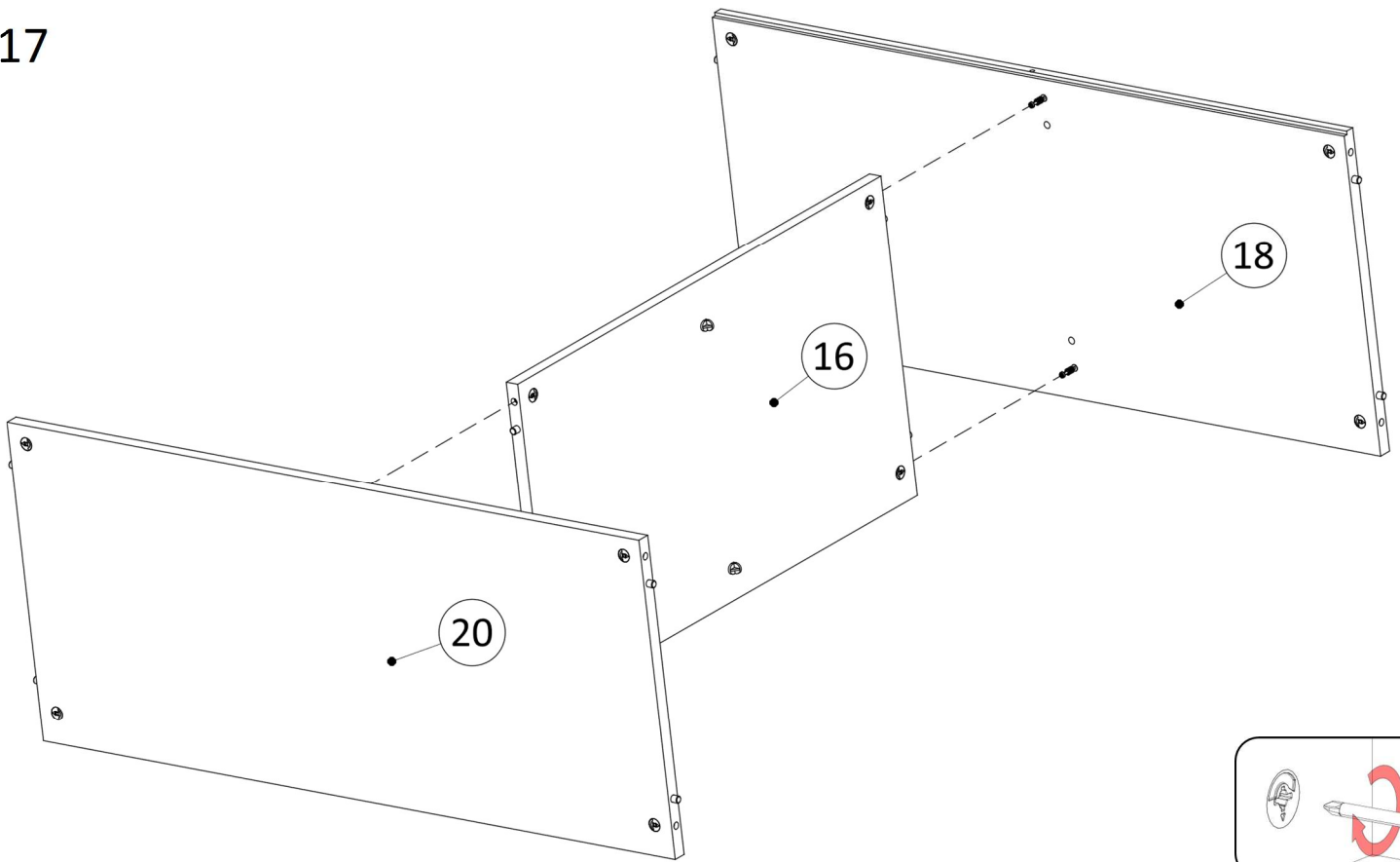

18

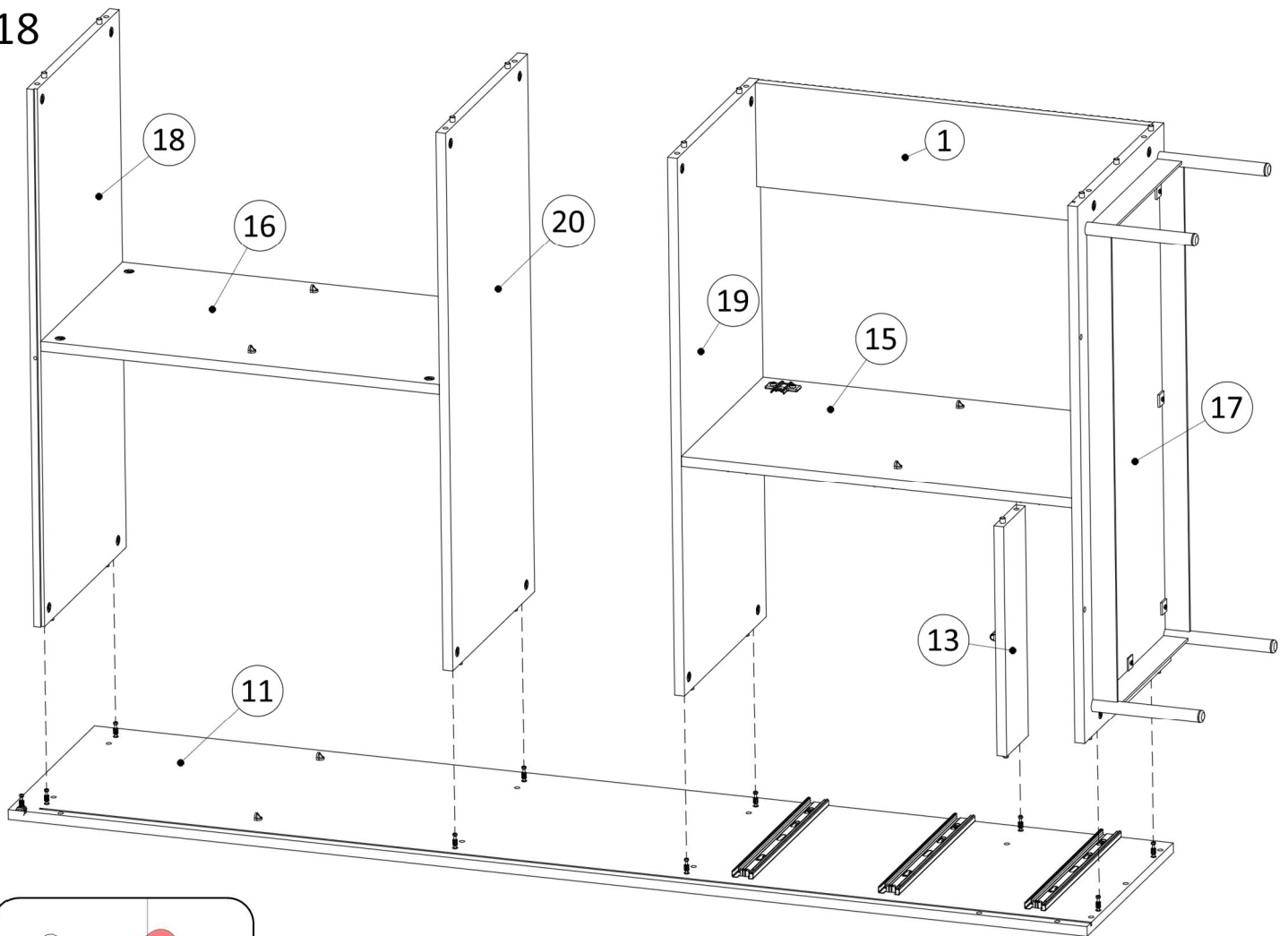

19

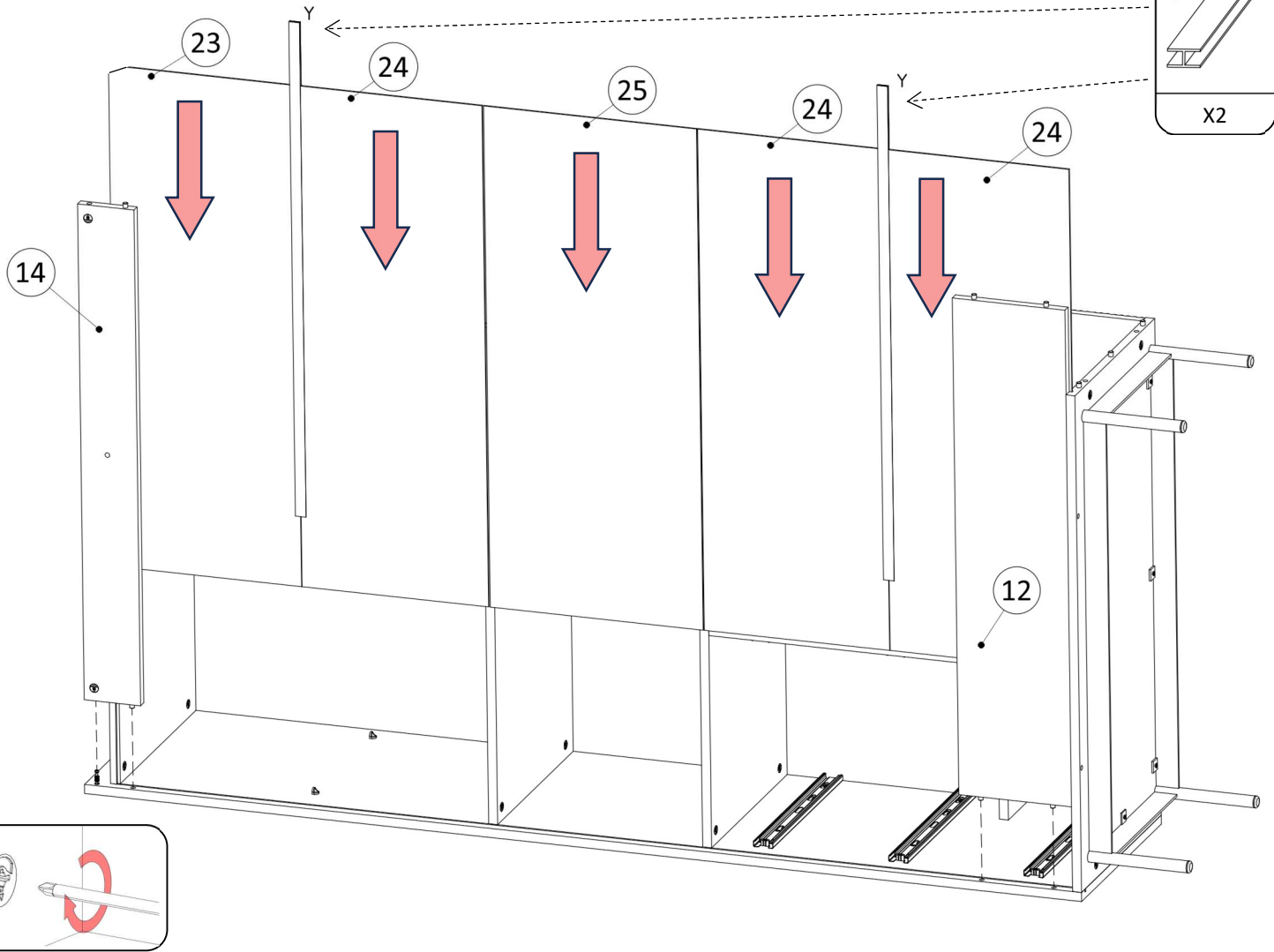

20

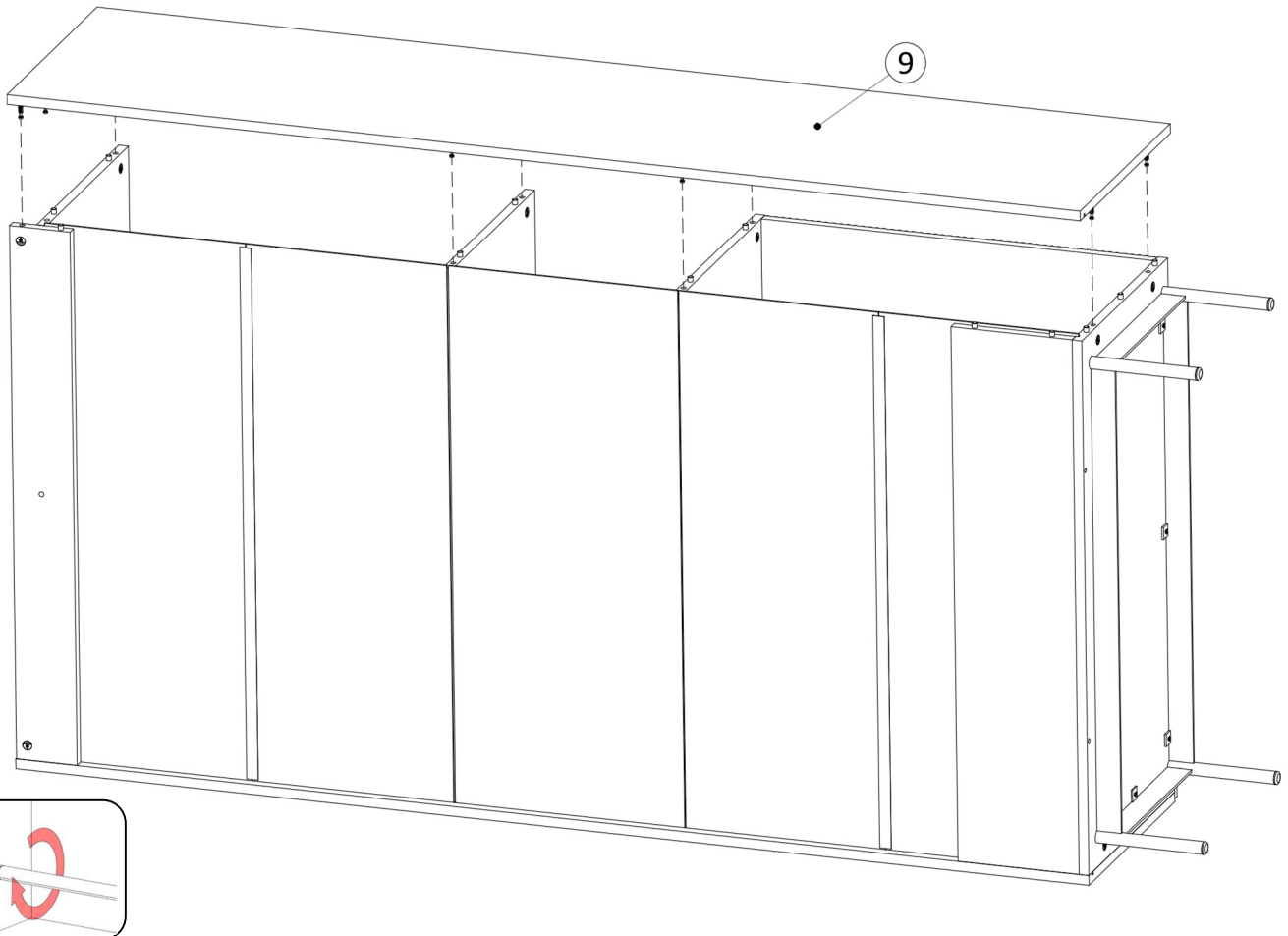

21

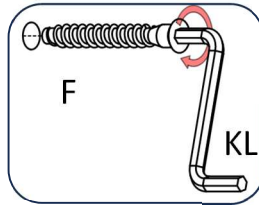
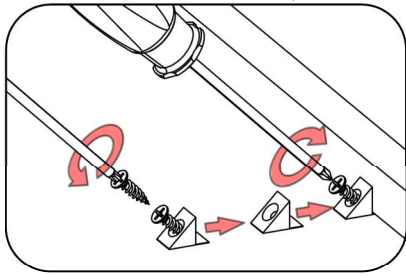
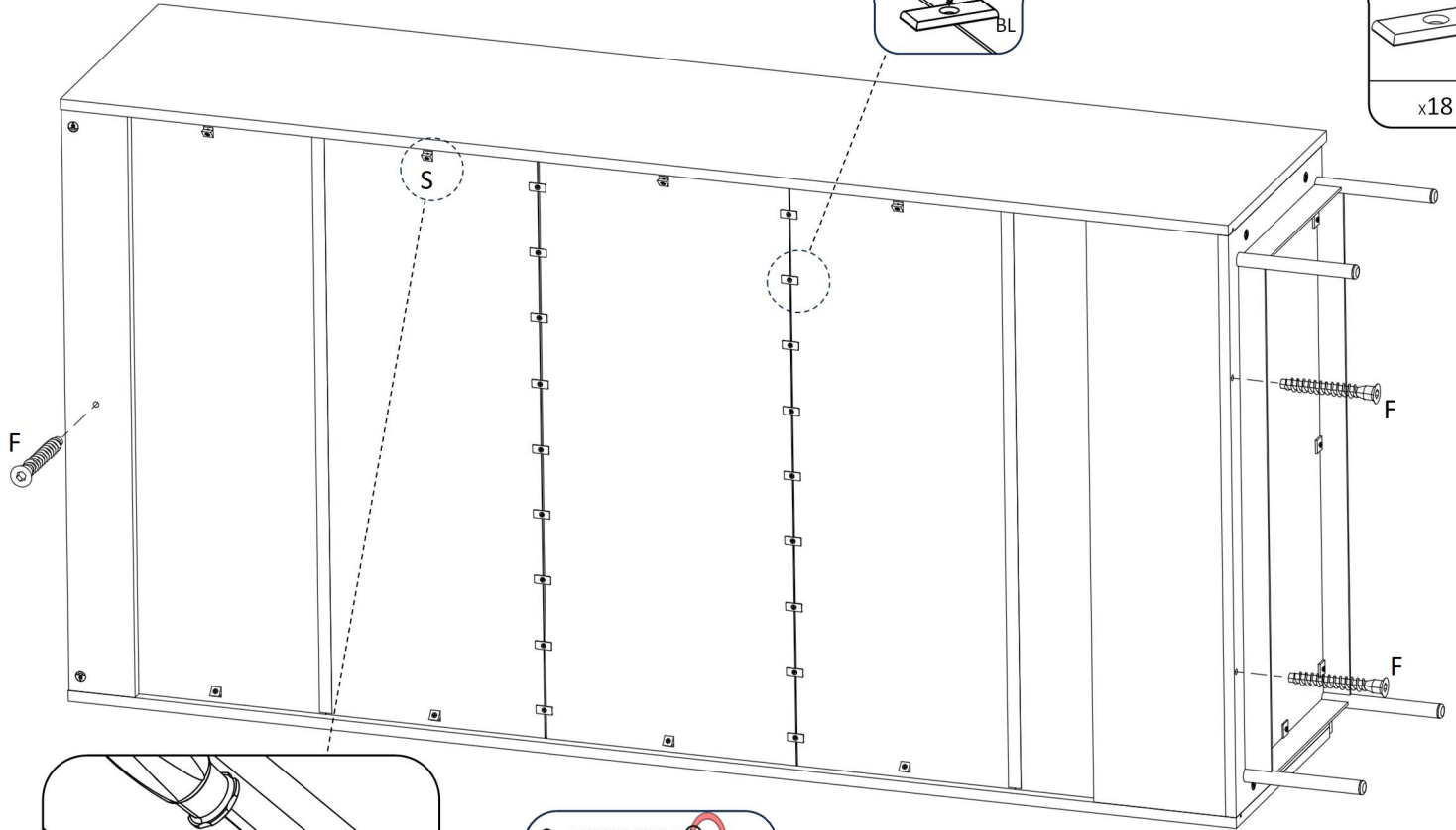
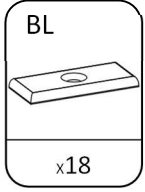
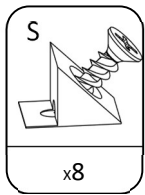
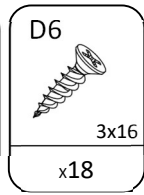
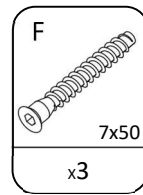
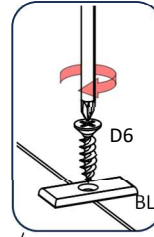
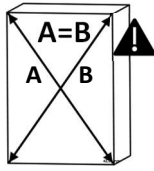
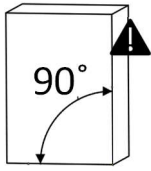

22

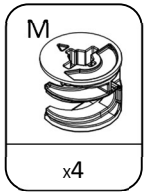
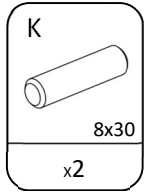
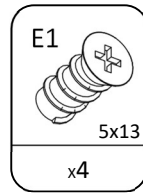

x3

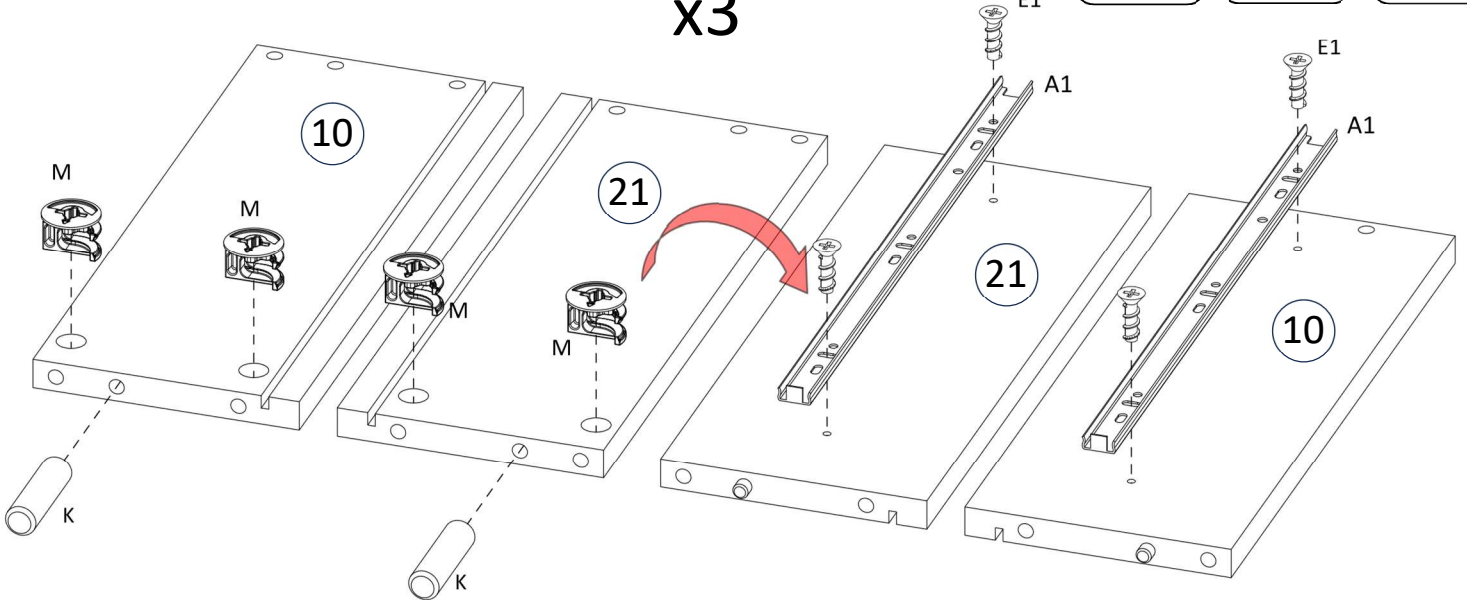

23

x3

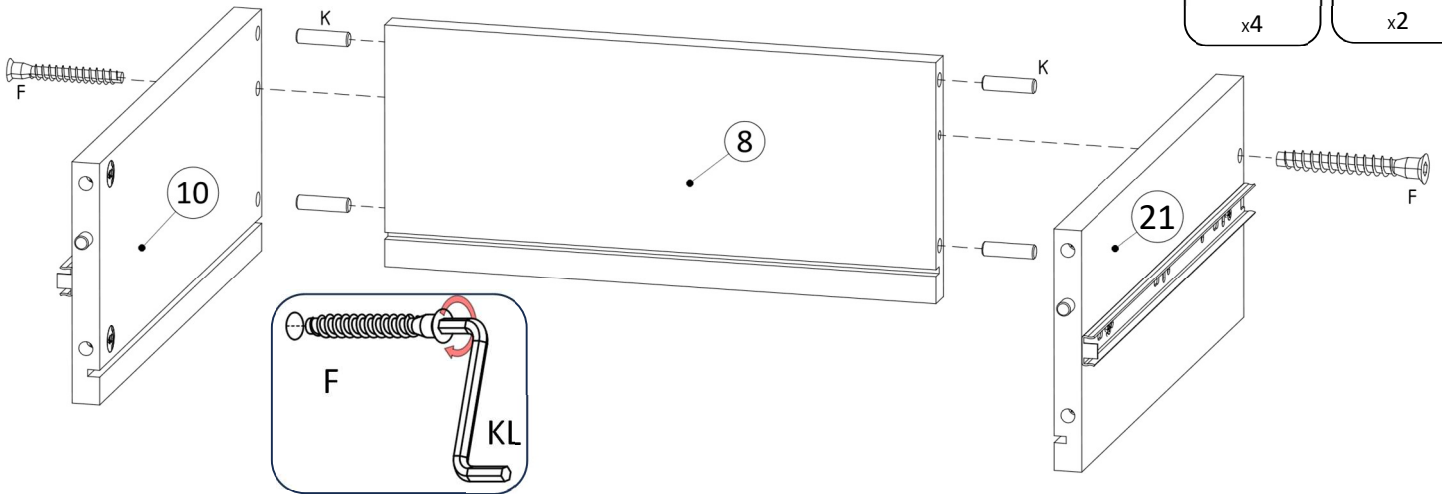
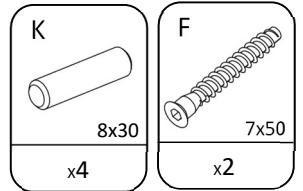

24

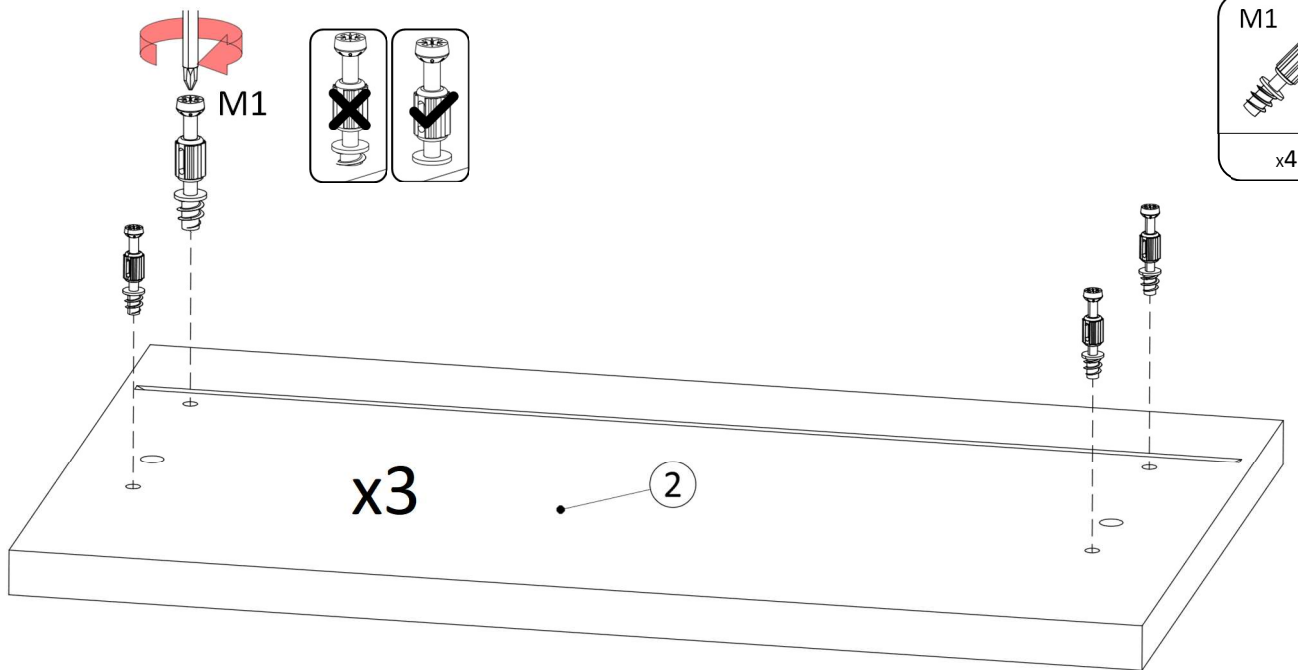

25

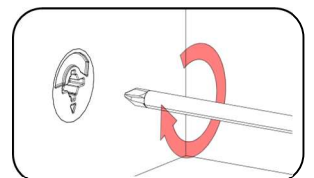
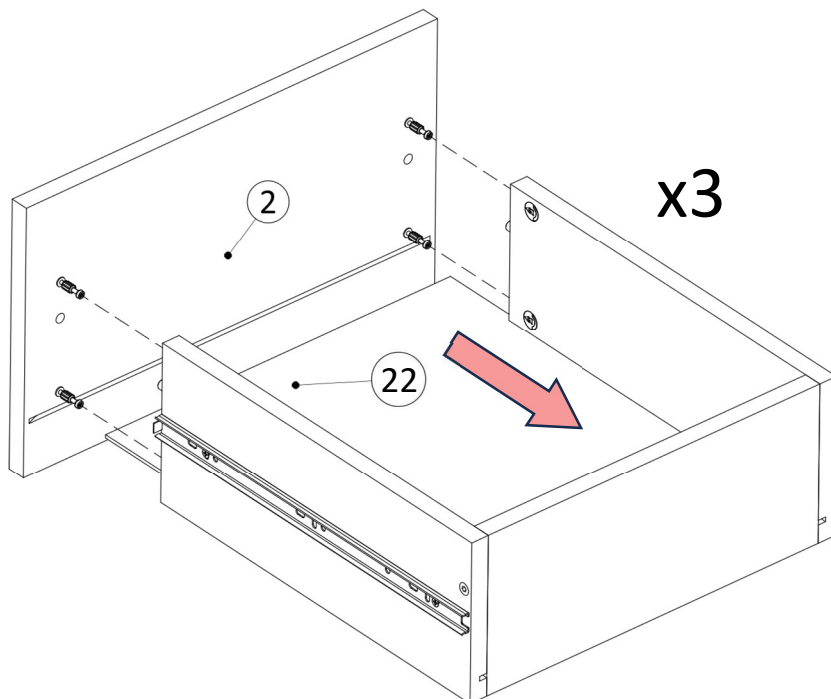

26

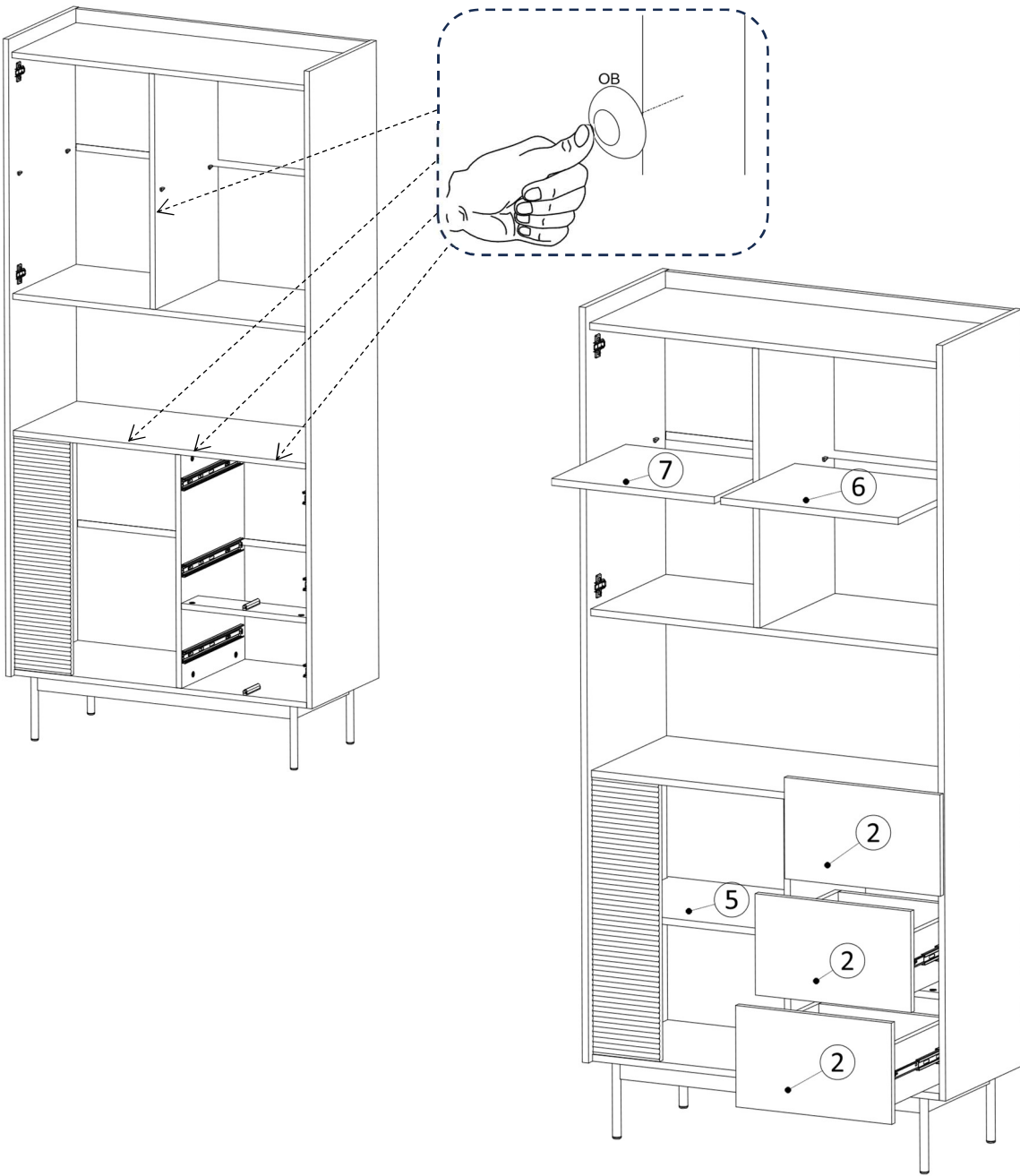
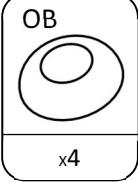

27

