

# CARMEN

R-1

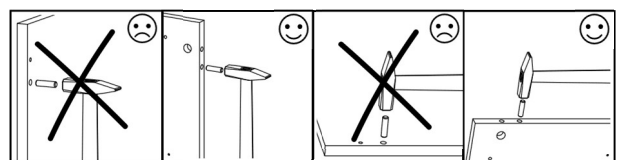

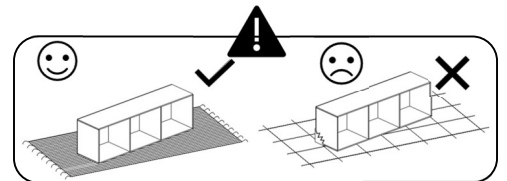
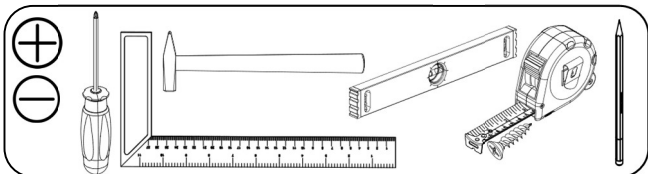
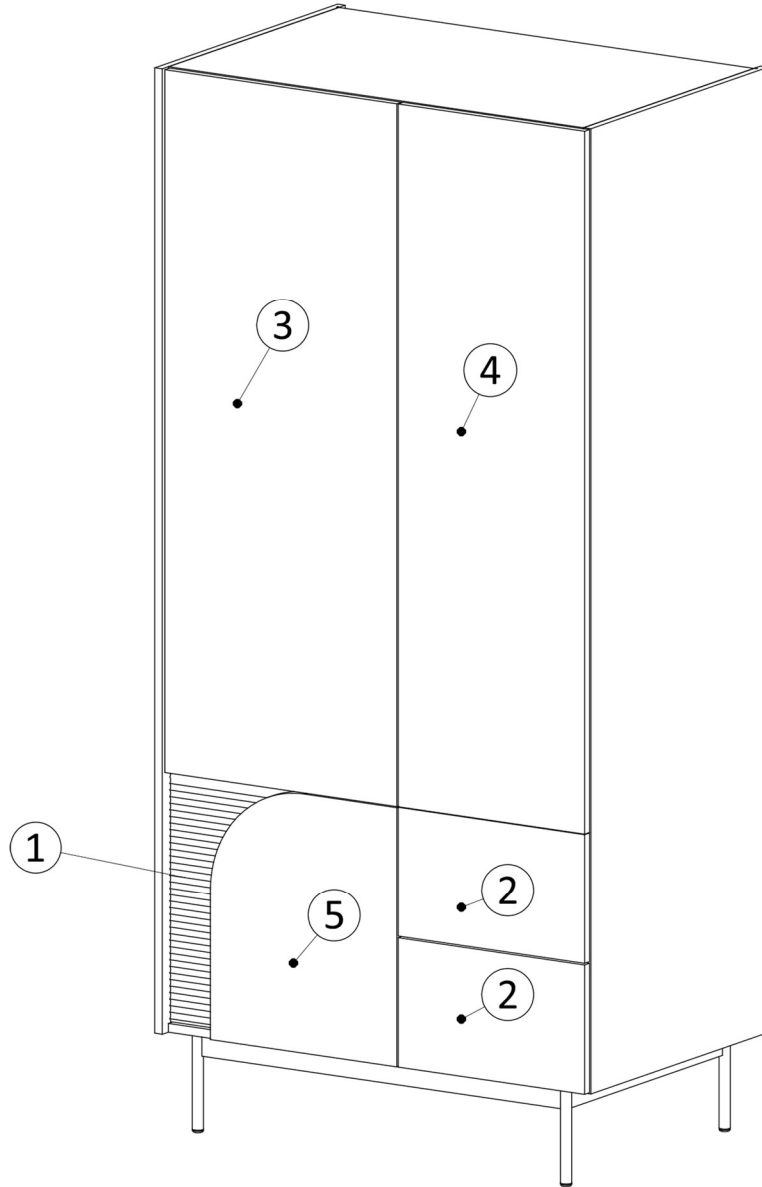
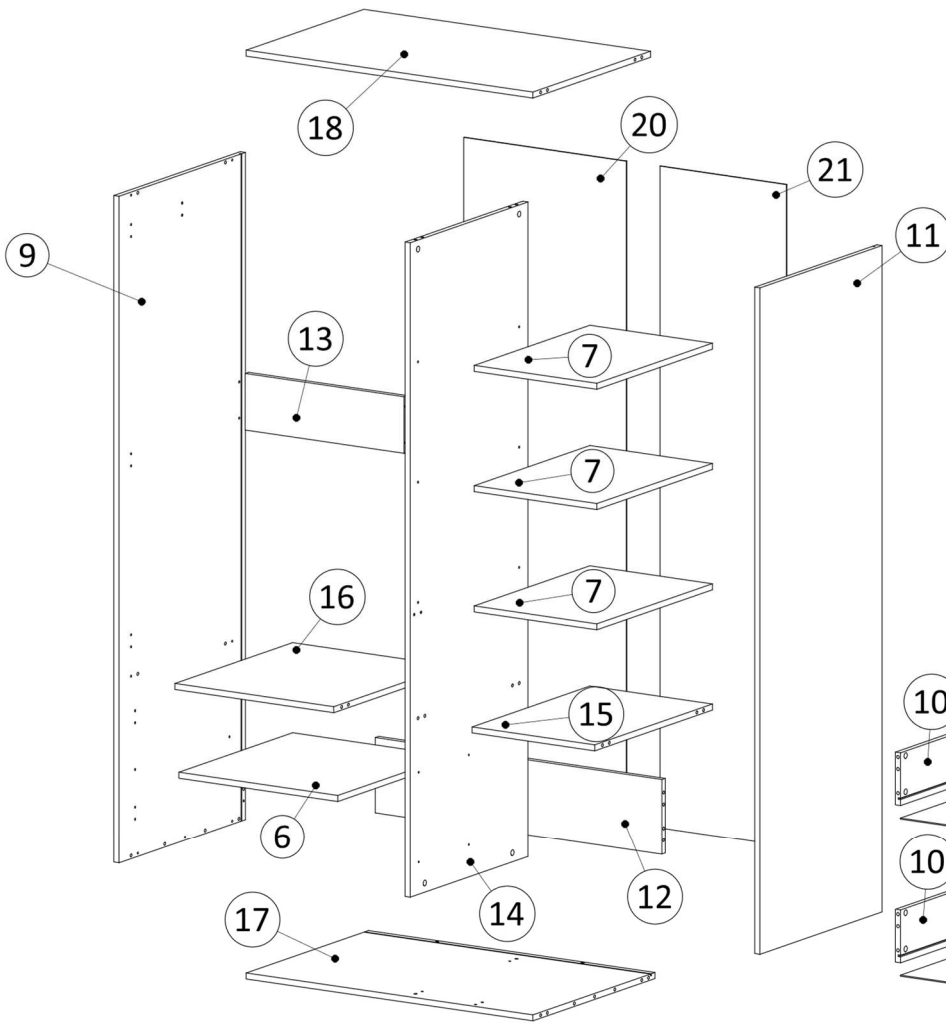

NO	T(mm)	L(mm)	W(mm)	pcs.
1	18	456	300	1
2	16	397	237	2
3	16	1286	494	1
4	16	1286	397	1
5	16	477	397	1
6	16	490	540	1
7	16	378	549	3
8	16	320	140	2
9	16	1770	600	1
10	16	350	140	2
11	16	1770	580	1
12	16	884	200	1
13	16	490	150	1
14	16	1738	559	1
15	16	378	559	1
16	16	490	559	1
17	16	884	580	1
18	16	884	559	1
19	3	333	346	2
20	3	1756	501	1
21	3	1756	389	1
22	16	350	140	2

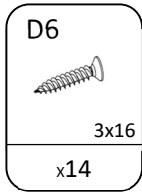
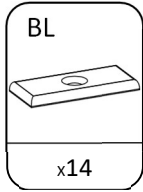
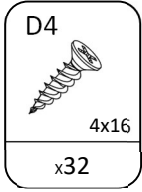
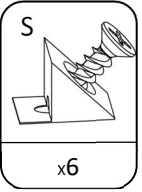
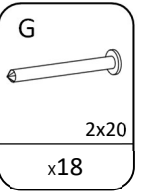
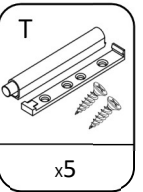
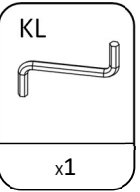
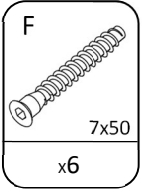
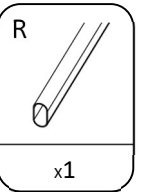
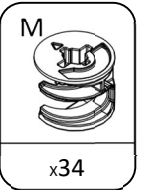
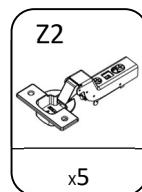
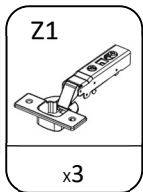
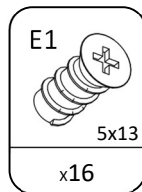
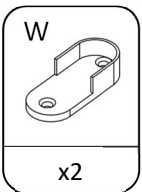
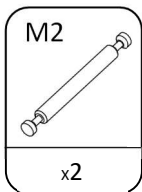
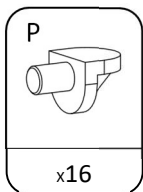
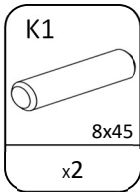
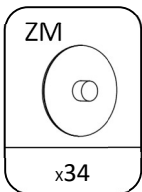
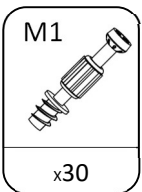
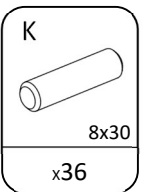
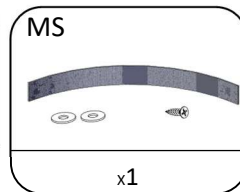
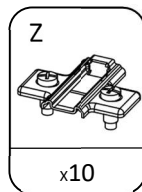
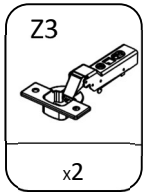
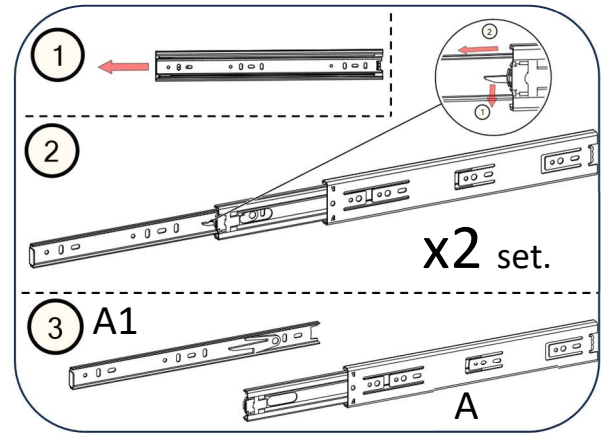
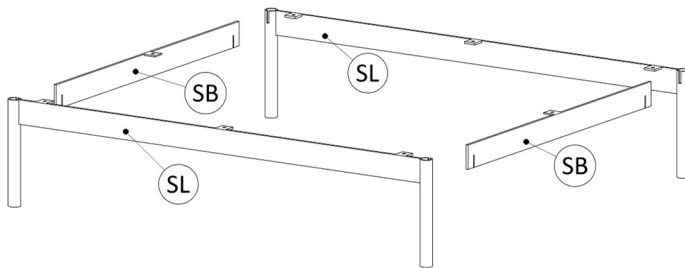
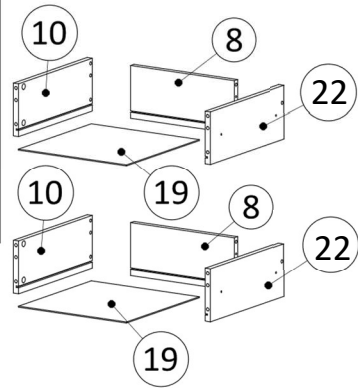

1

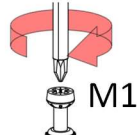
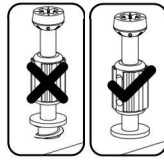

M1	K	M
x2	x4	x4

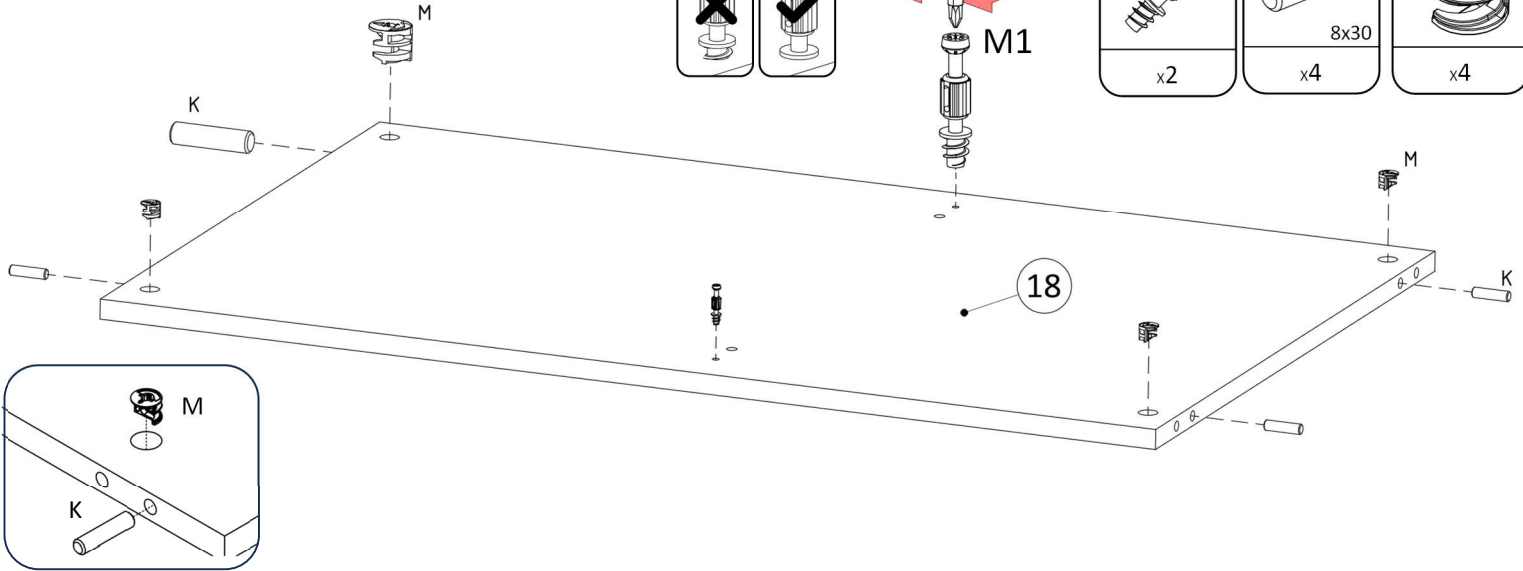

2

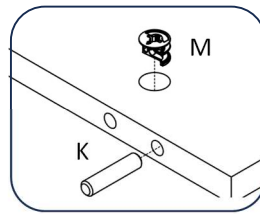

K	M
x8	x6

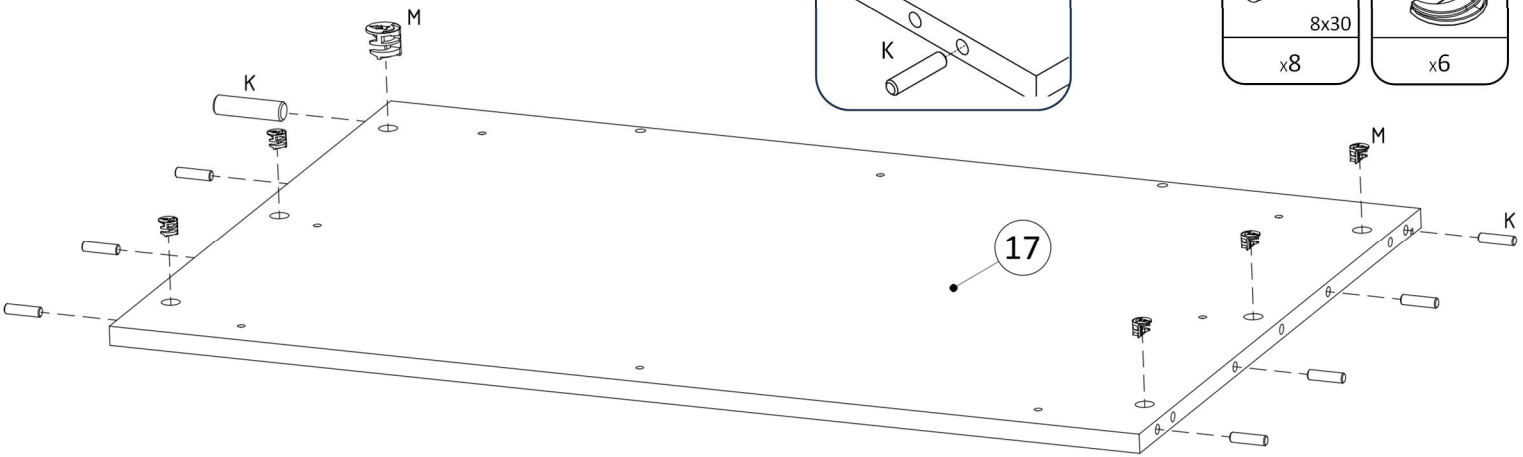

3

D4
4x16
x8

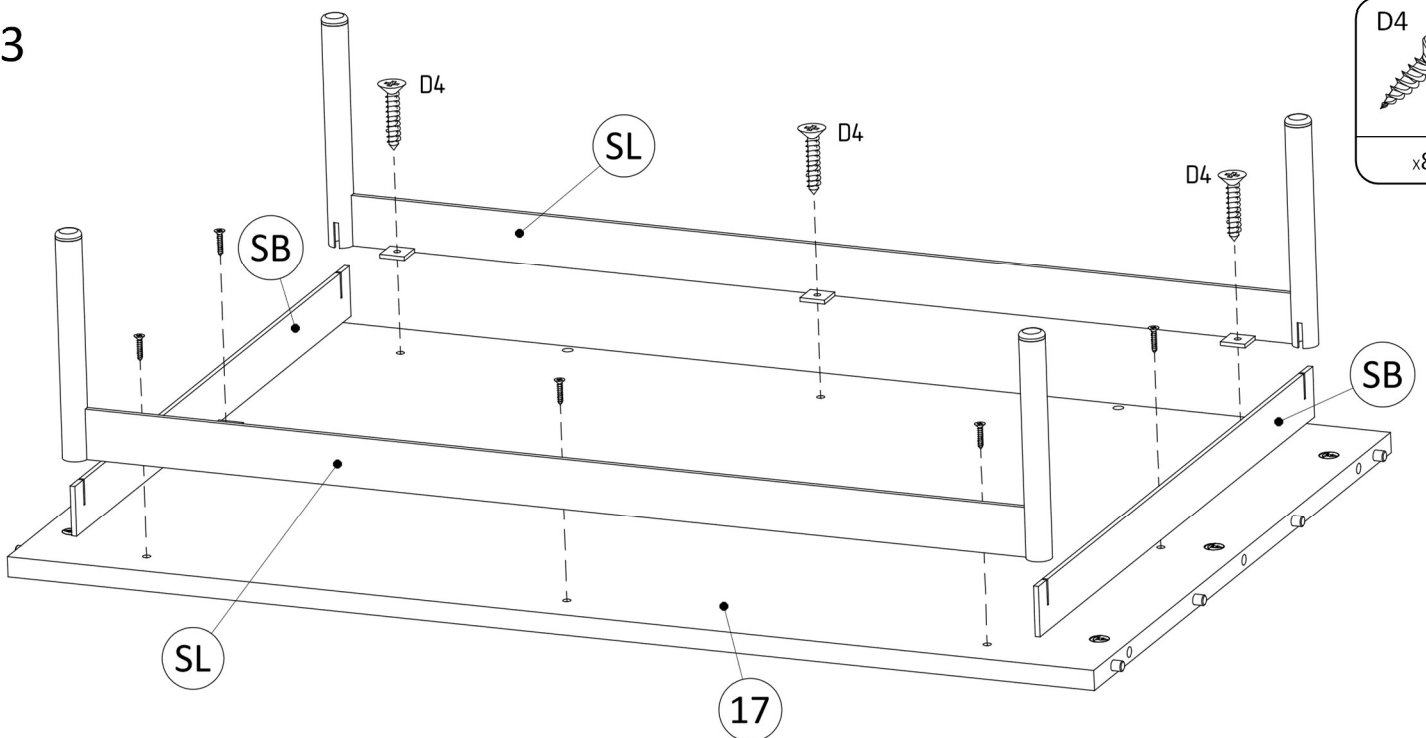

4

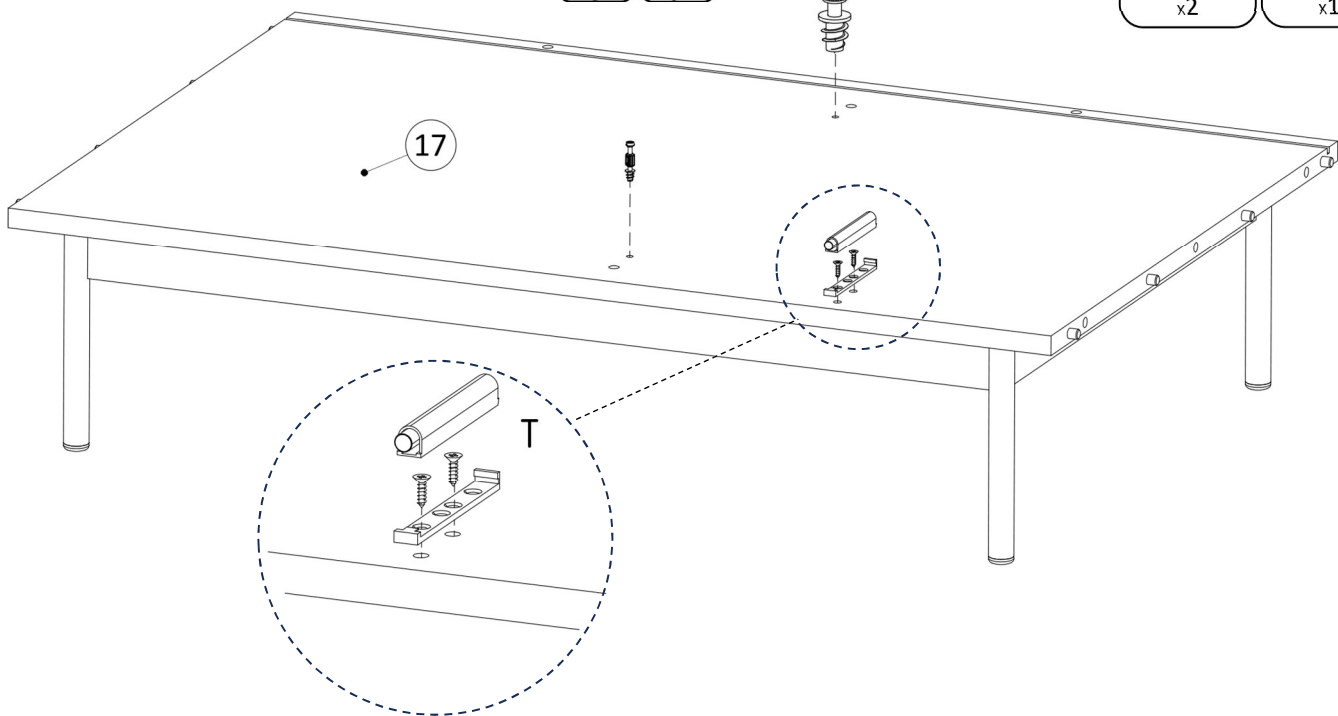
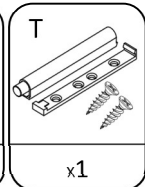
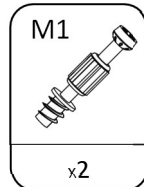
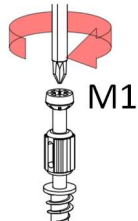
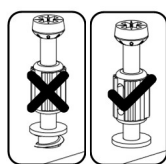

5

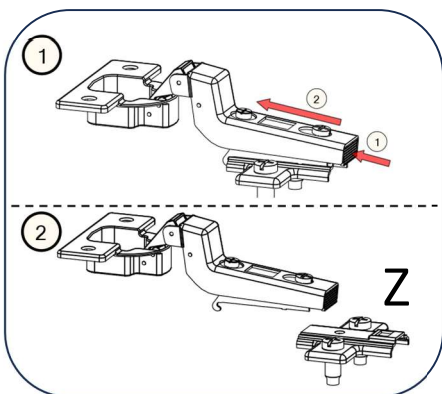
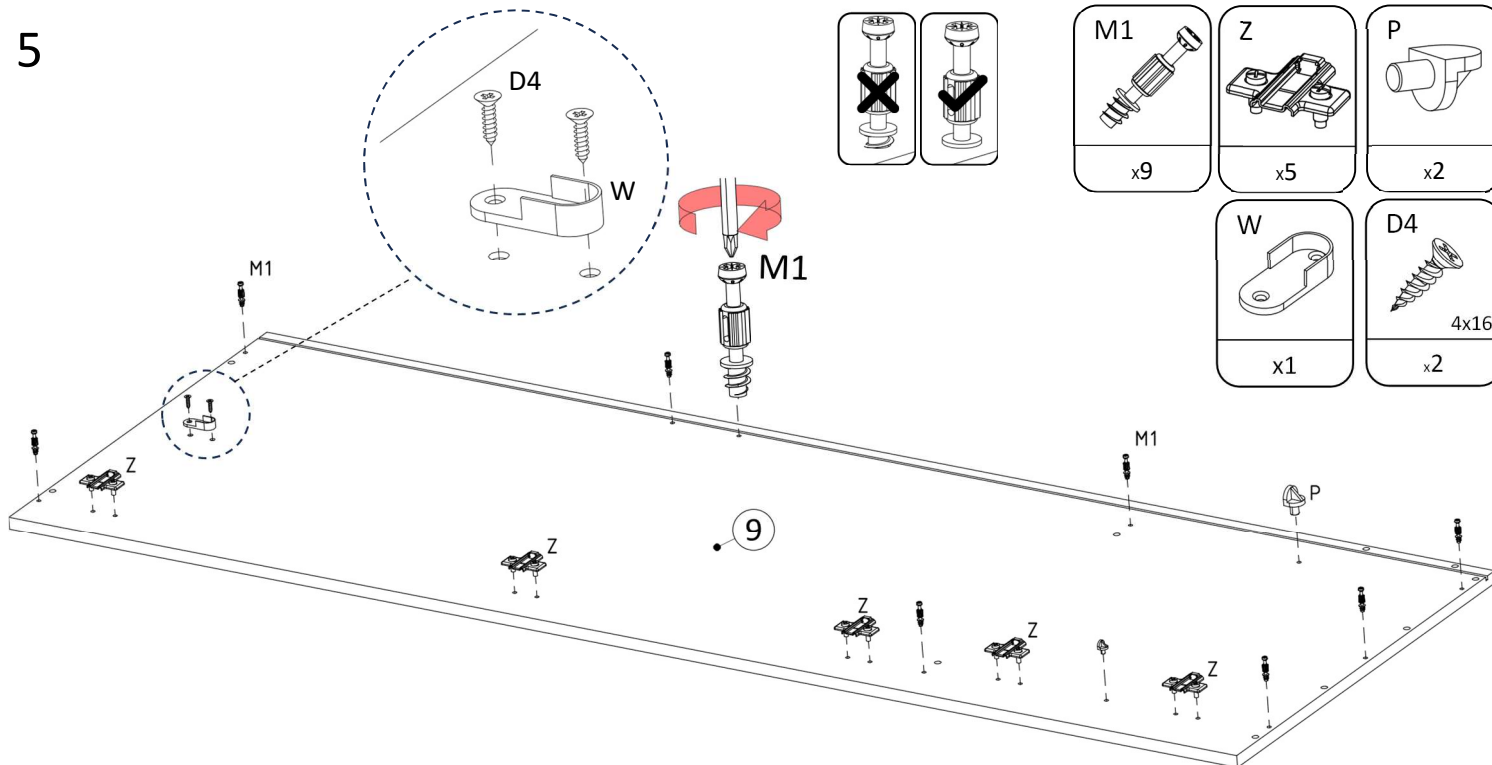
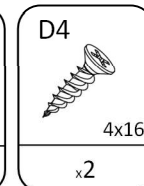
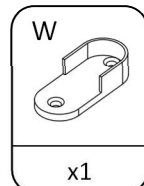
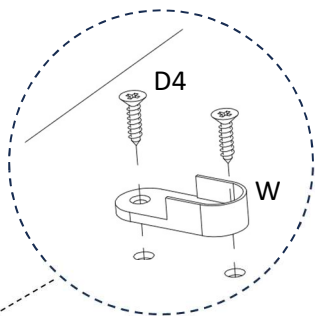
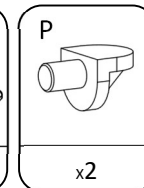
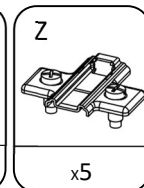
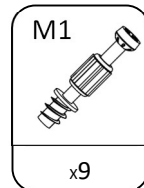
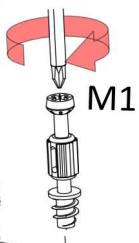
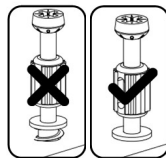

6

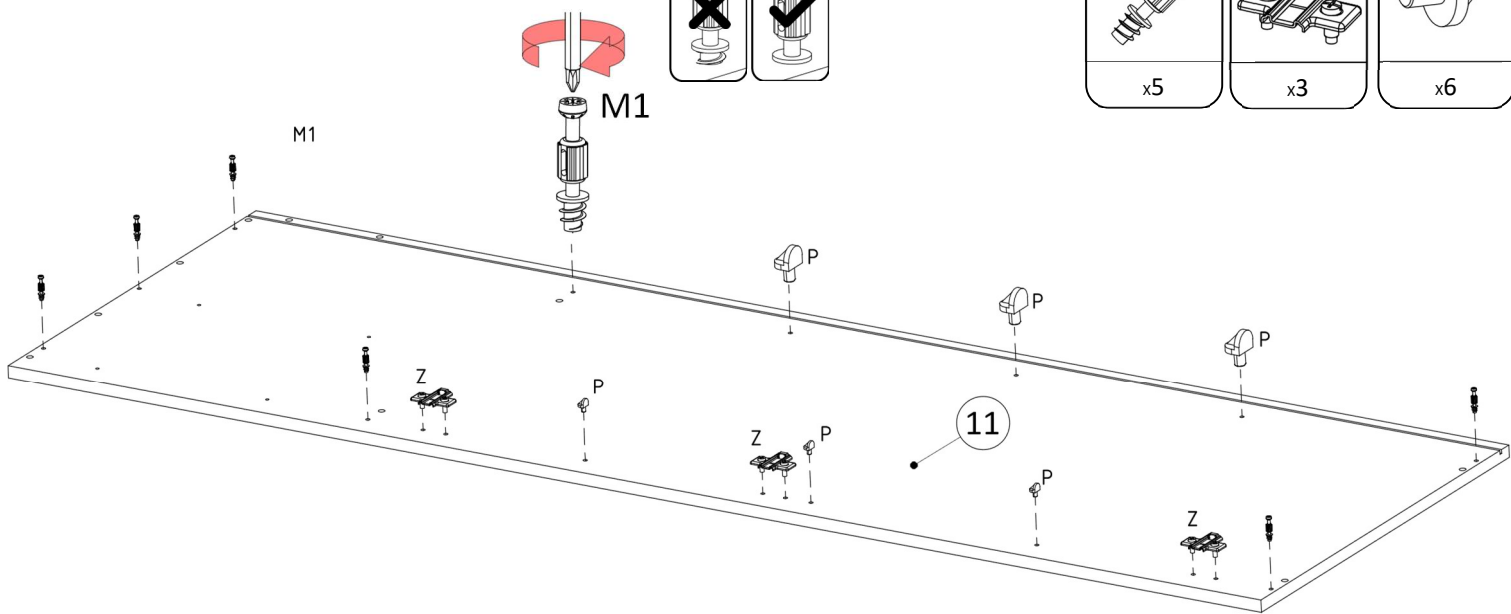
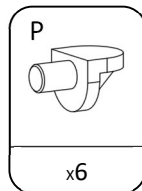
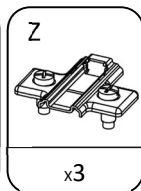
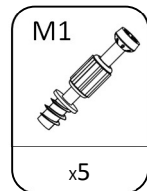
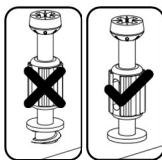

7

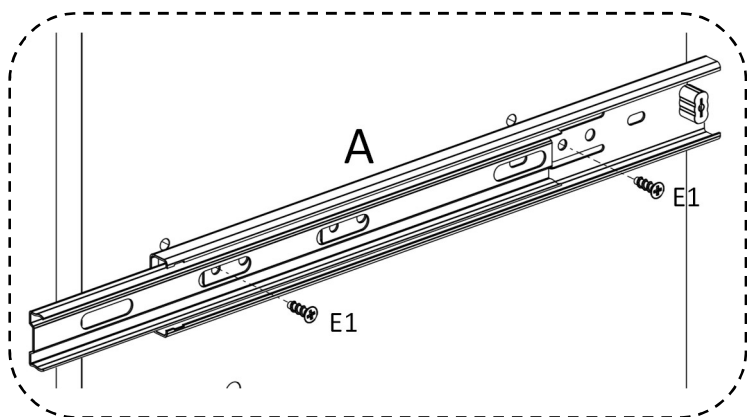
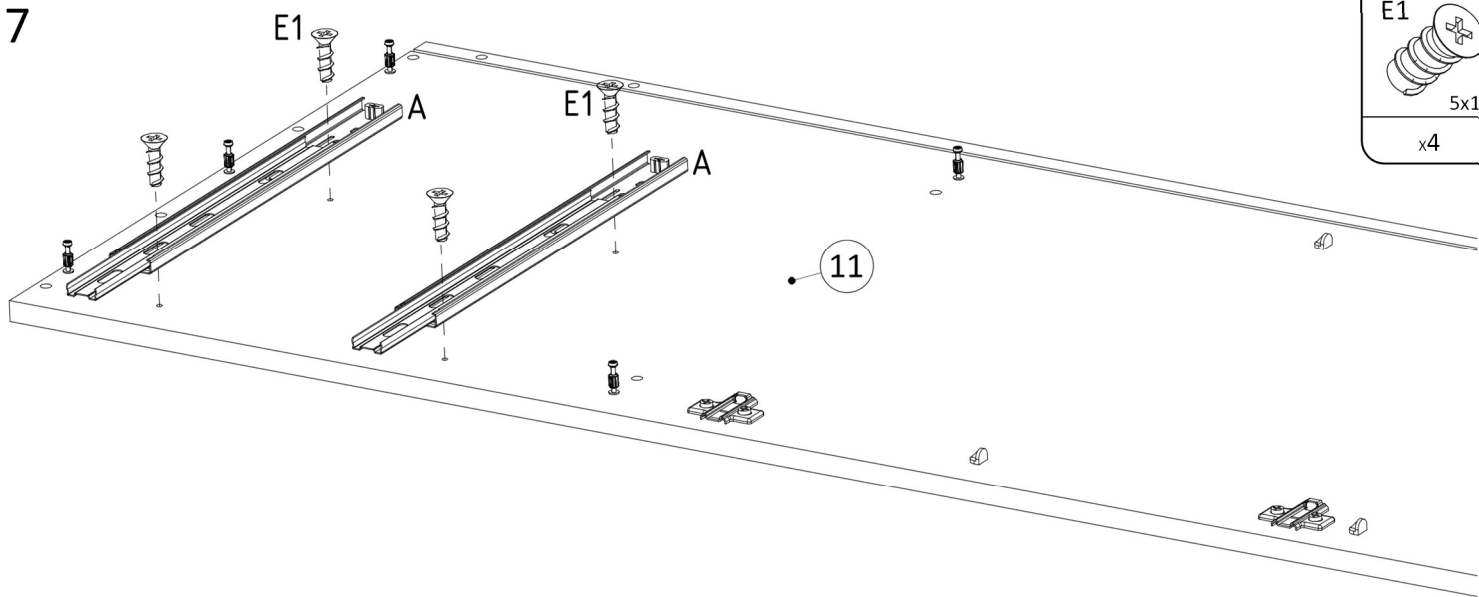
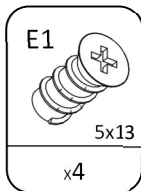

8

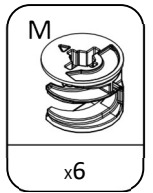
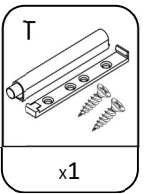
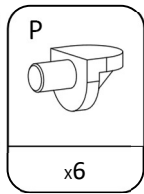
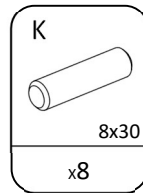
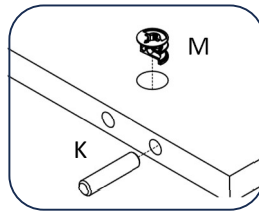
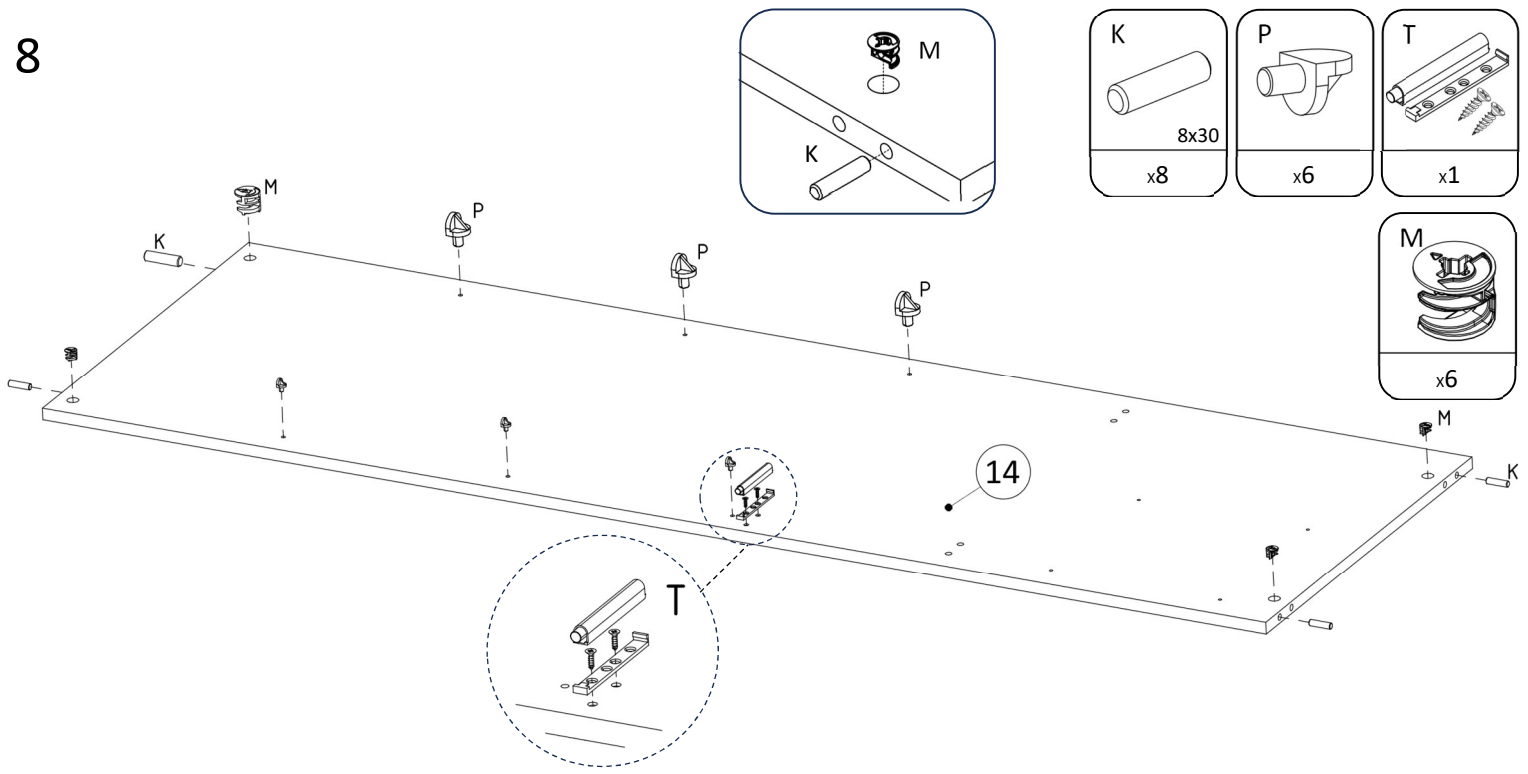

9

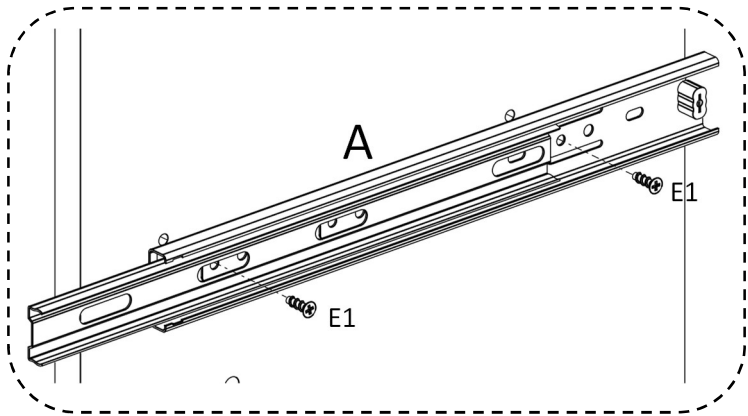
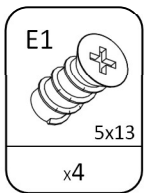
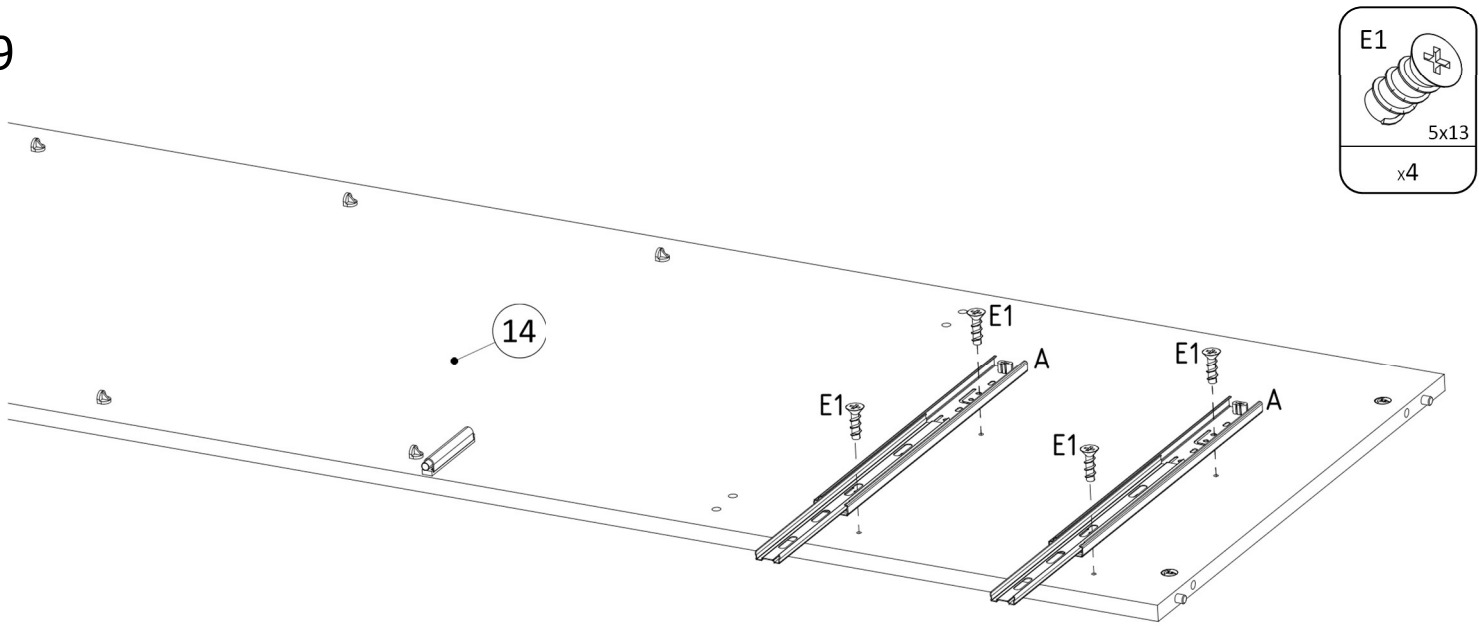

10

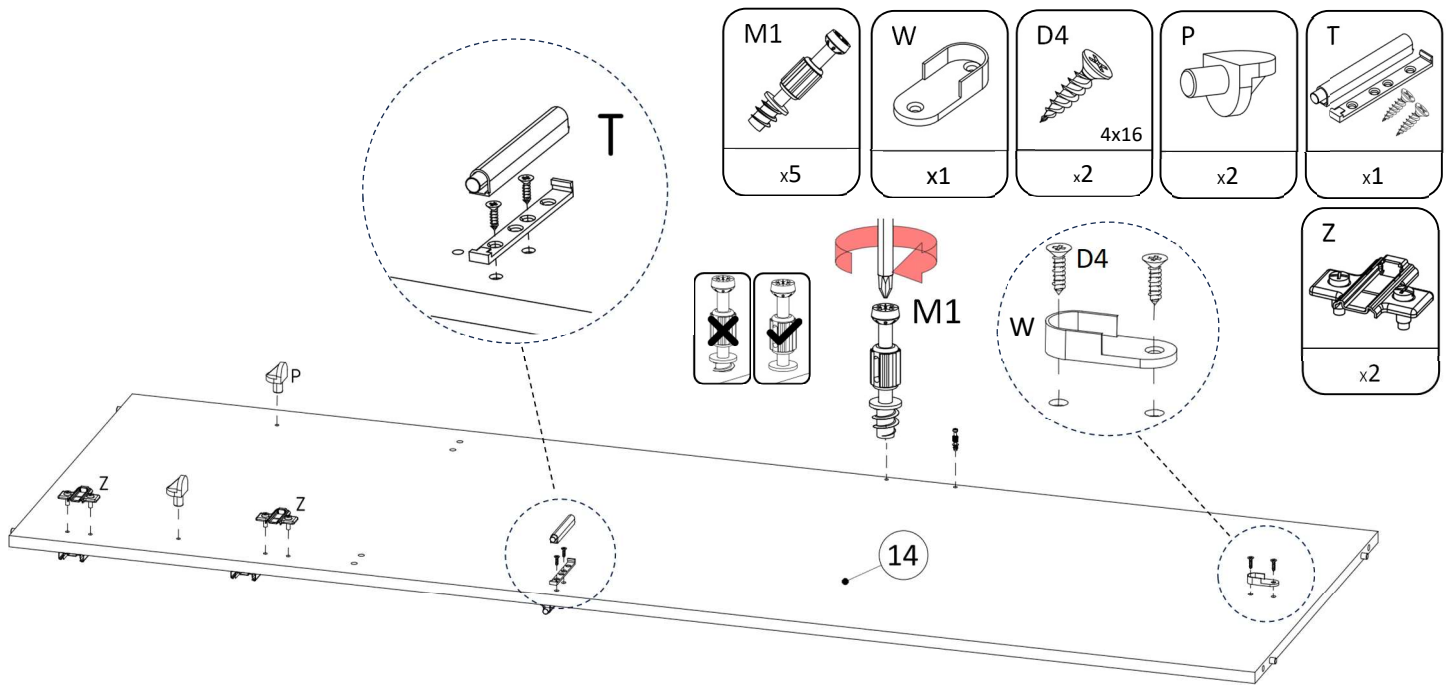

11

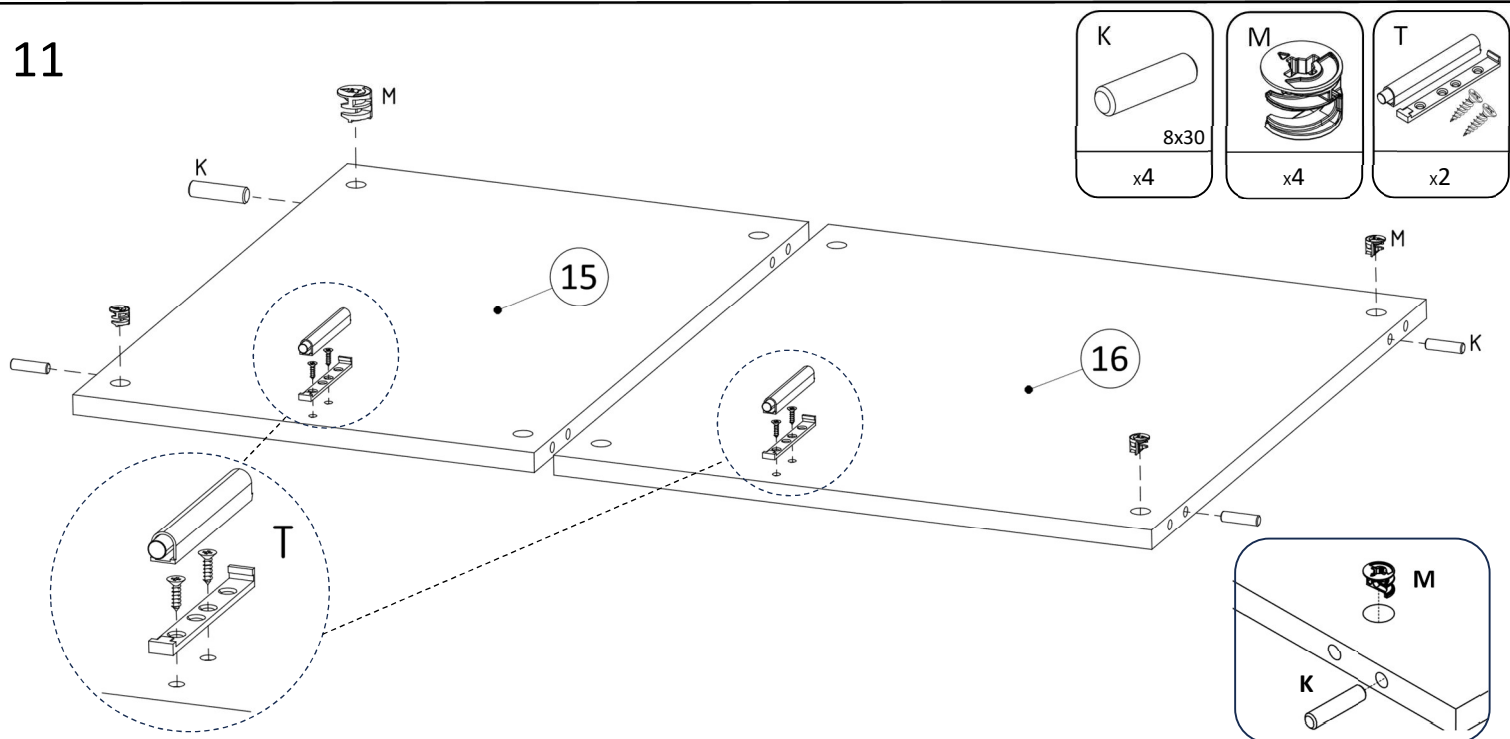

12

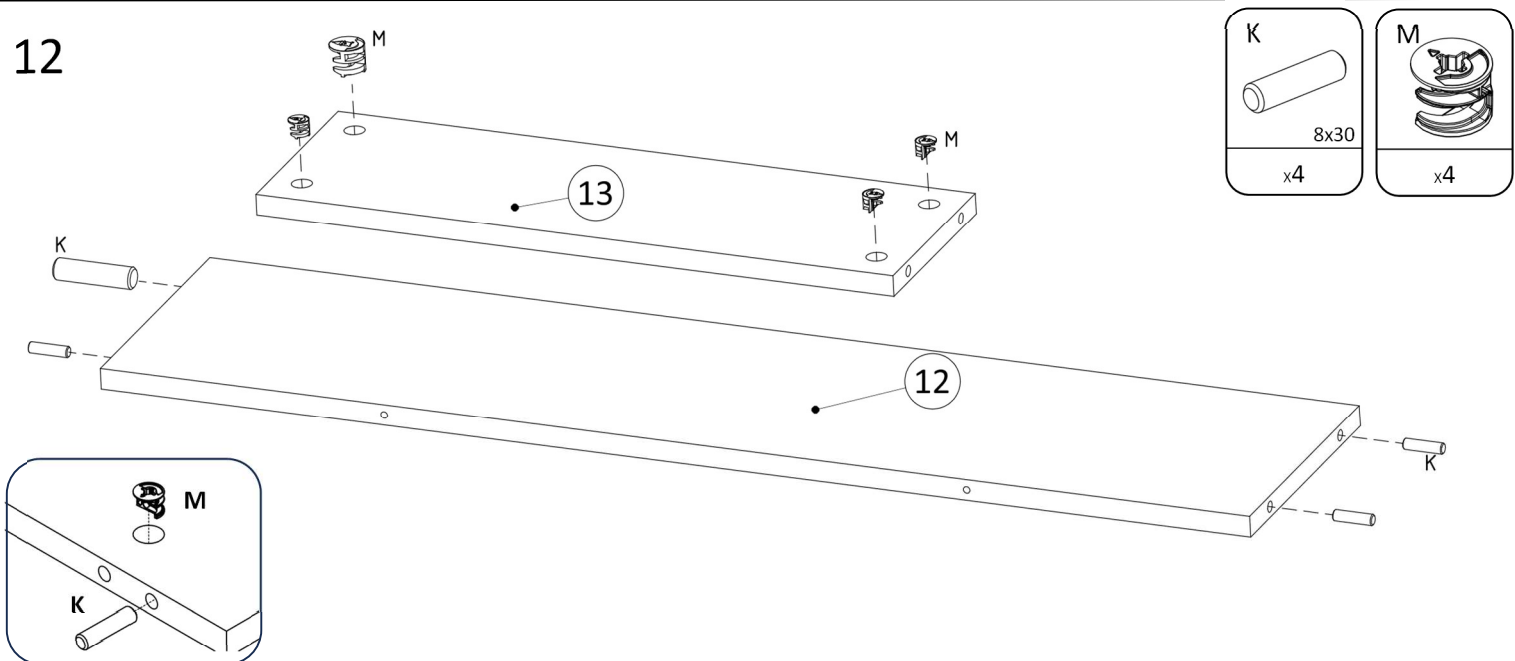

13

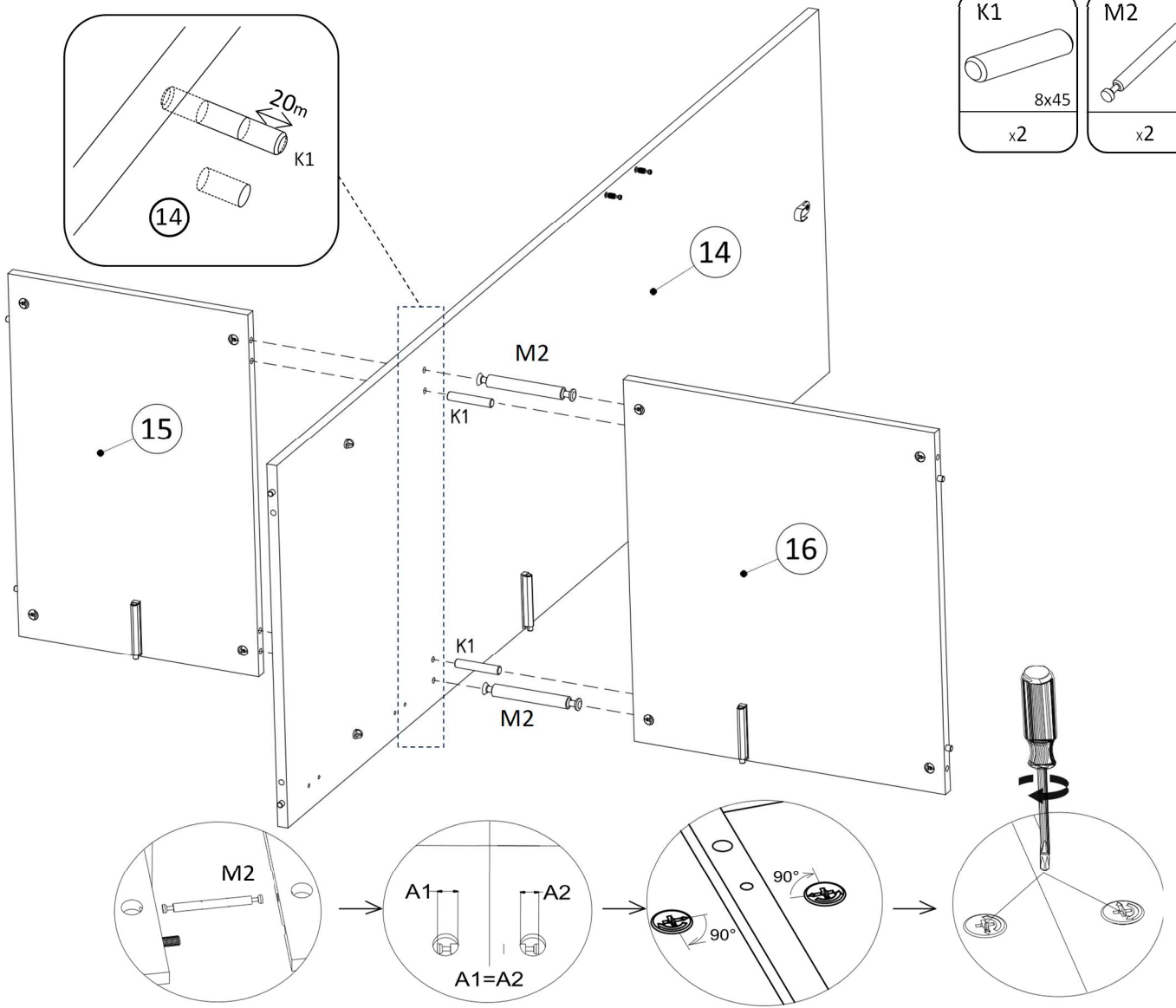

14

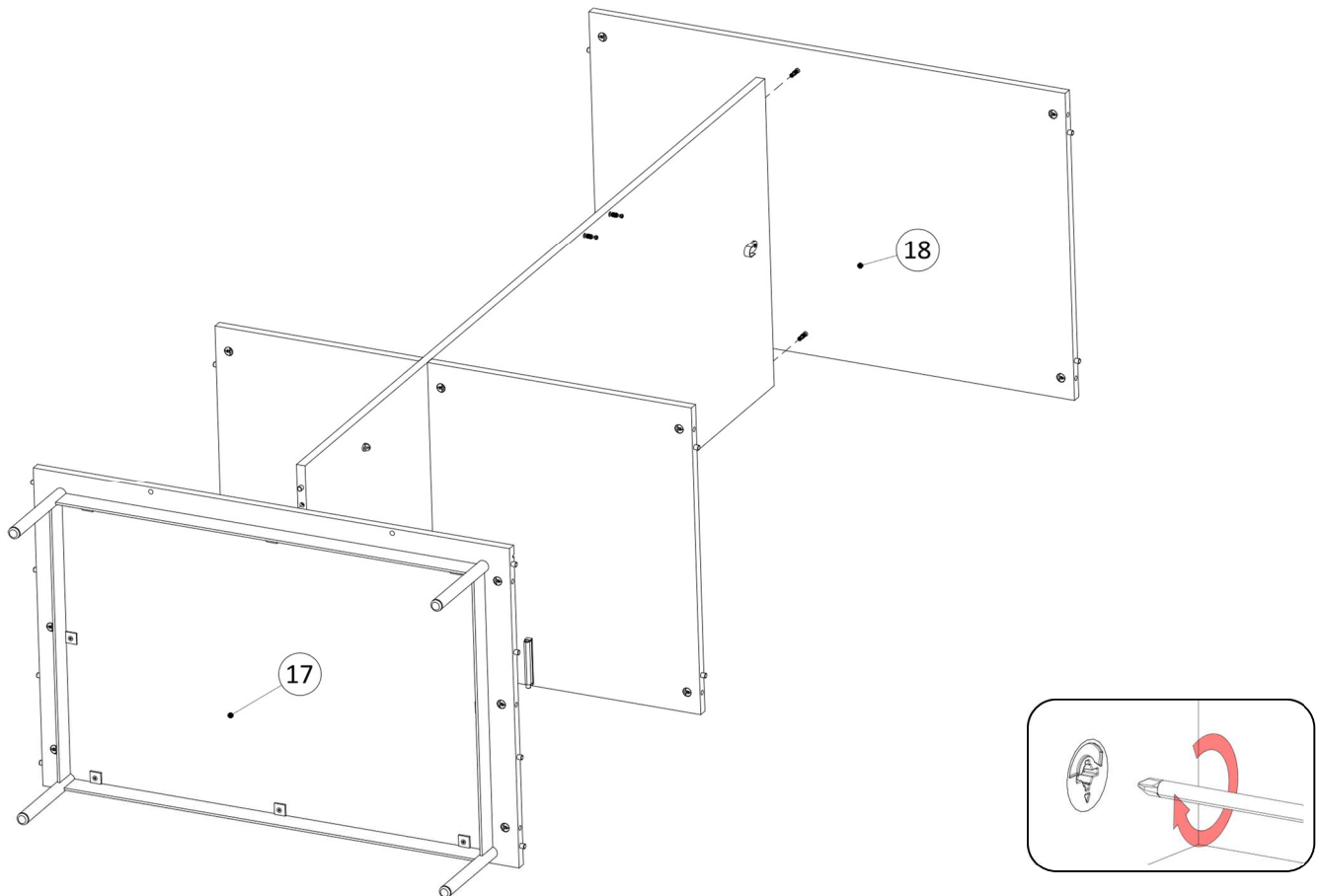

15

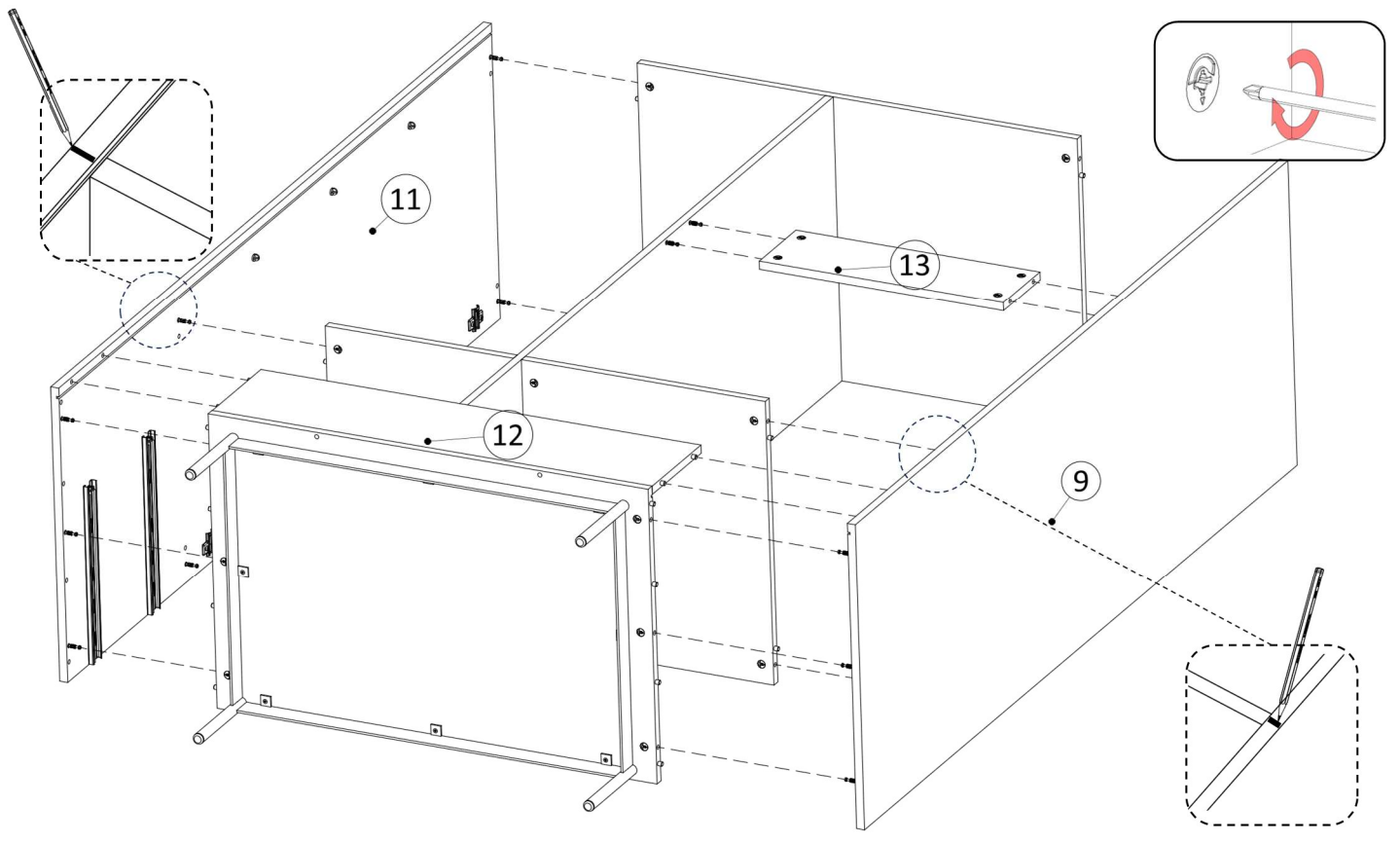

16

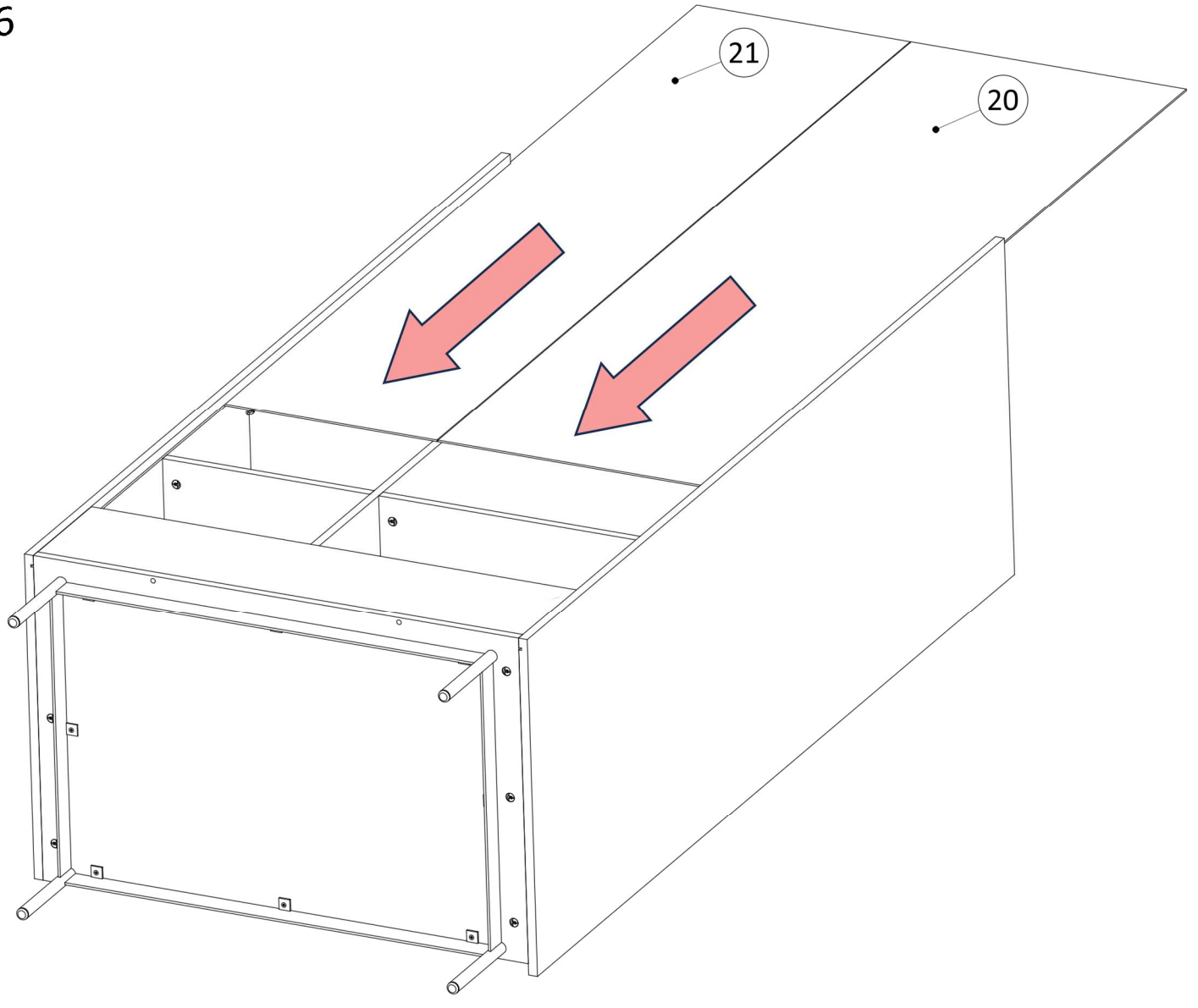

17

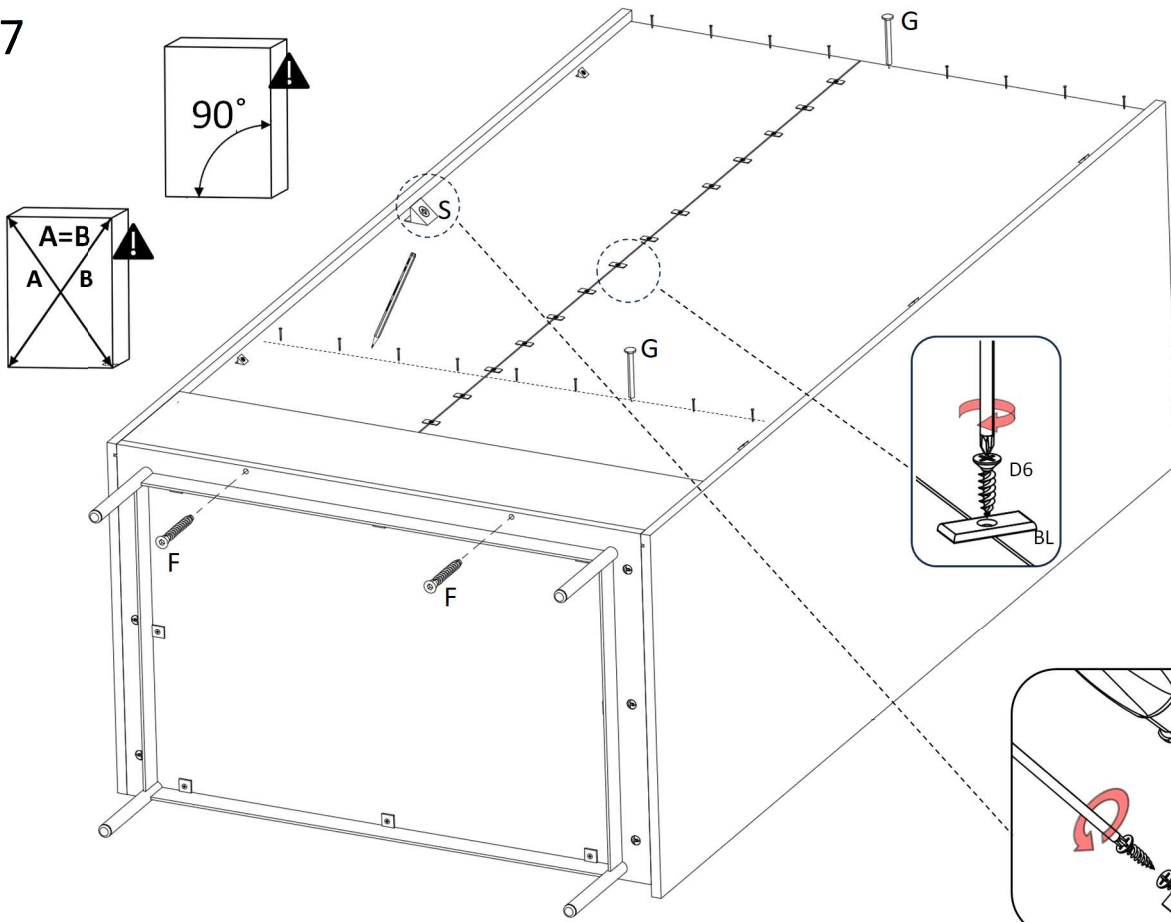

- |                   |           |
|-------------------|-----------|
| D6<br>3x16<br>x14 | S<br>x6   |
| F<br>7x50<br>x2   | BL<br>x14 |
| G<br>2x20<br>x18  |           |

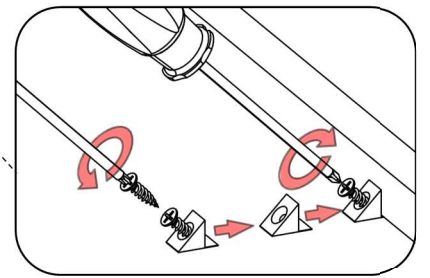

18

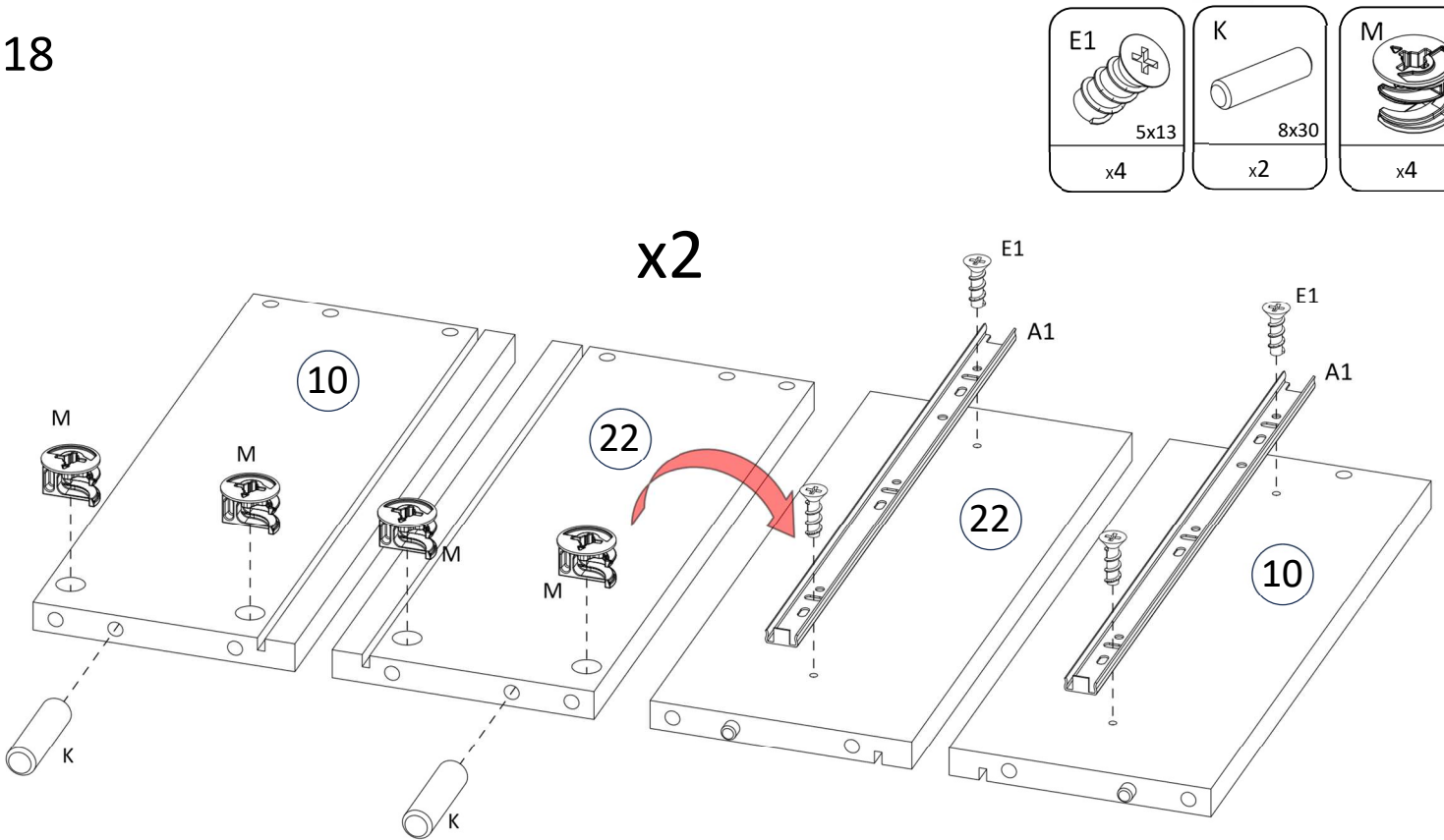

- |                  |                 |         |
|------------------|-----------------|---------|
| E1<br>5x13<br>x4 | K<br>8x30<br>x2 | M<br>x4 |
|------------------|-----------------|---------|

19

x2

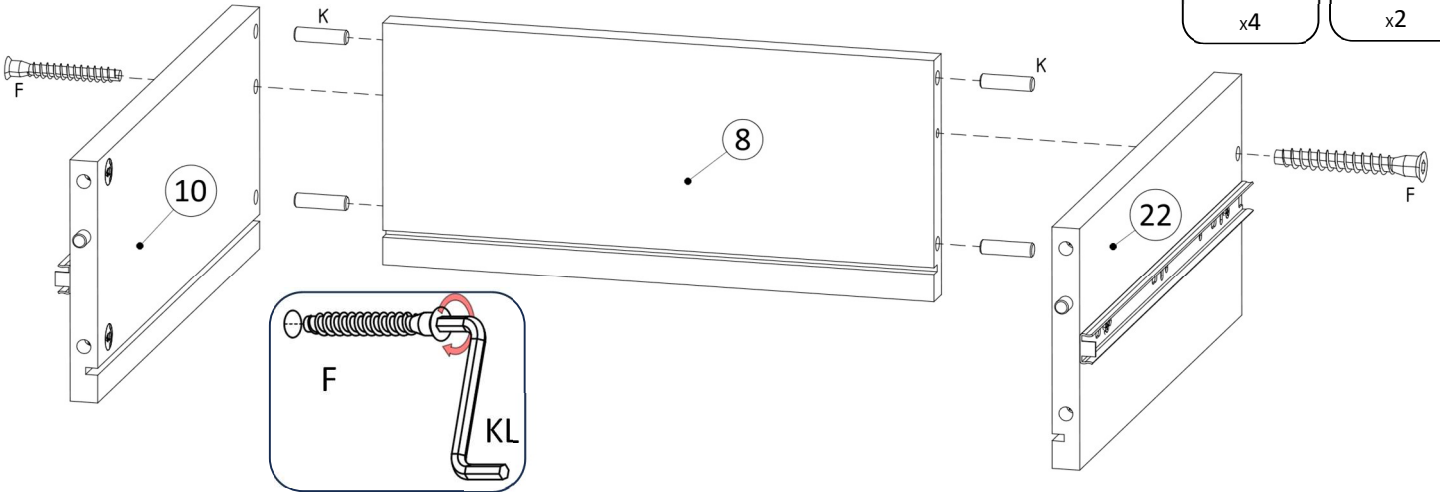
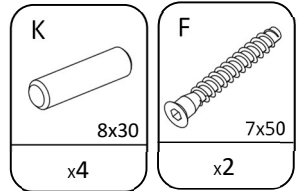

20

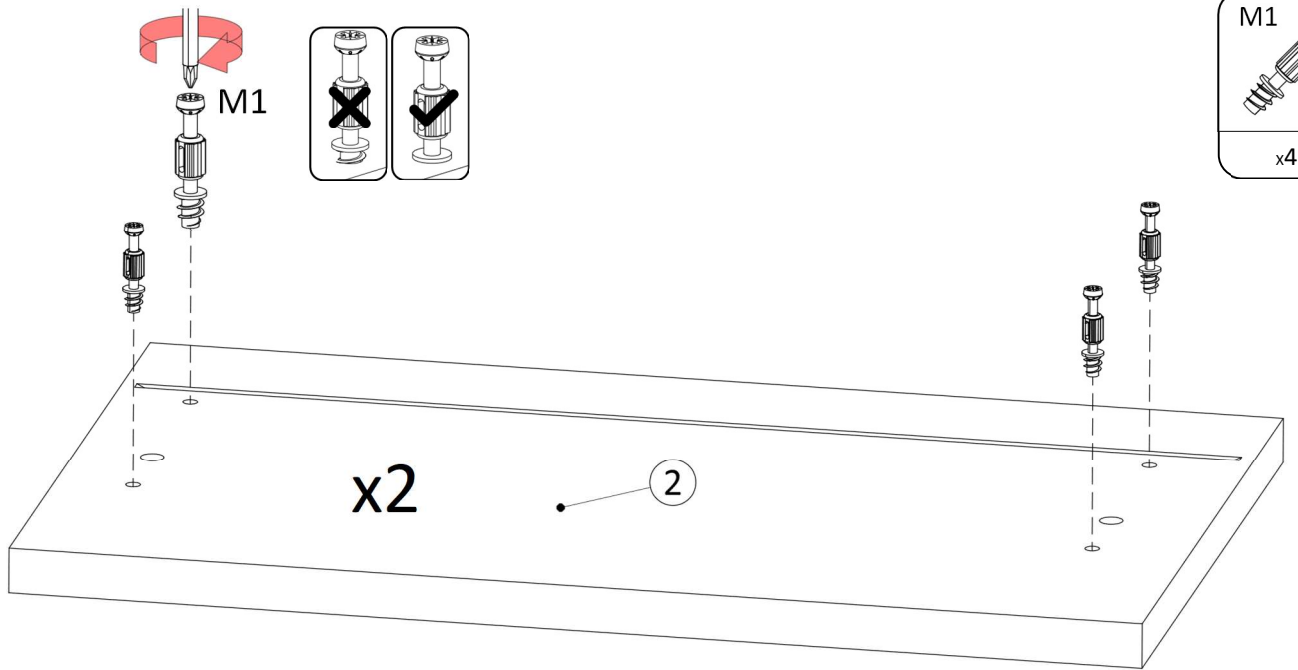

21

x2

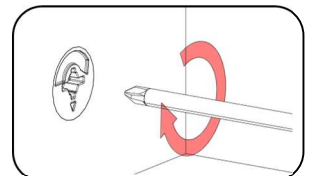
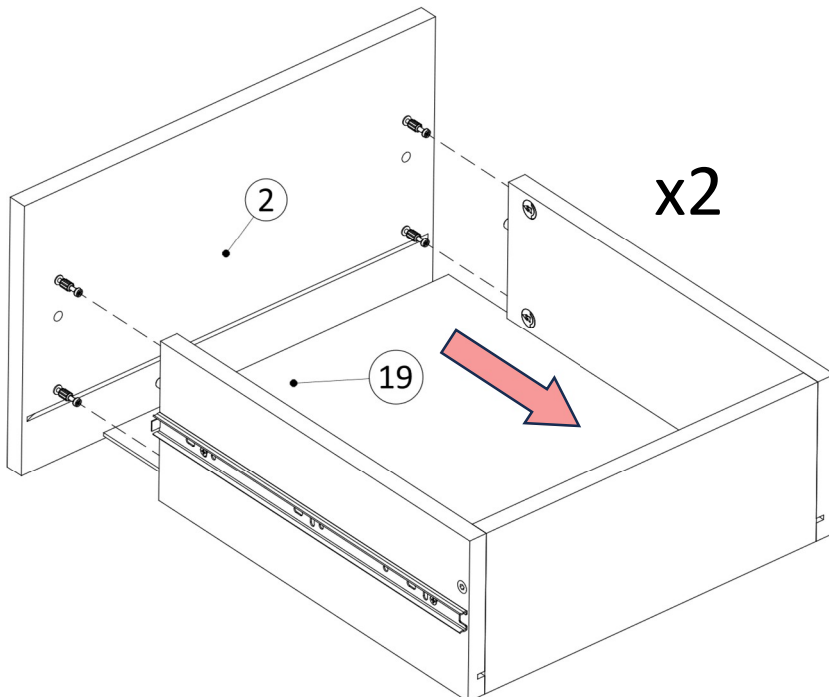

22

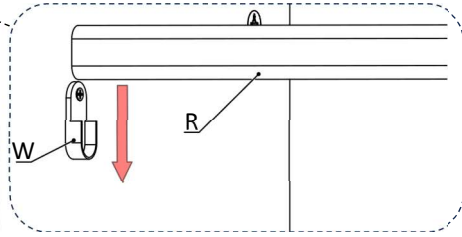
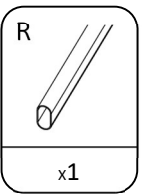
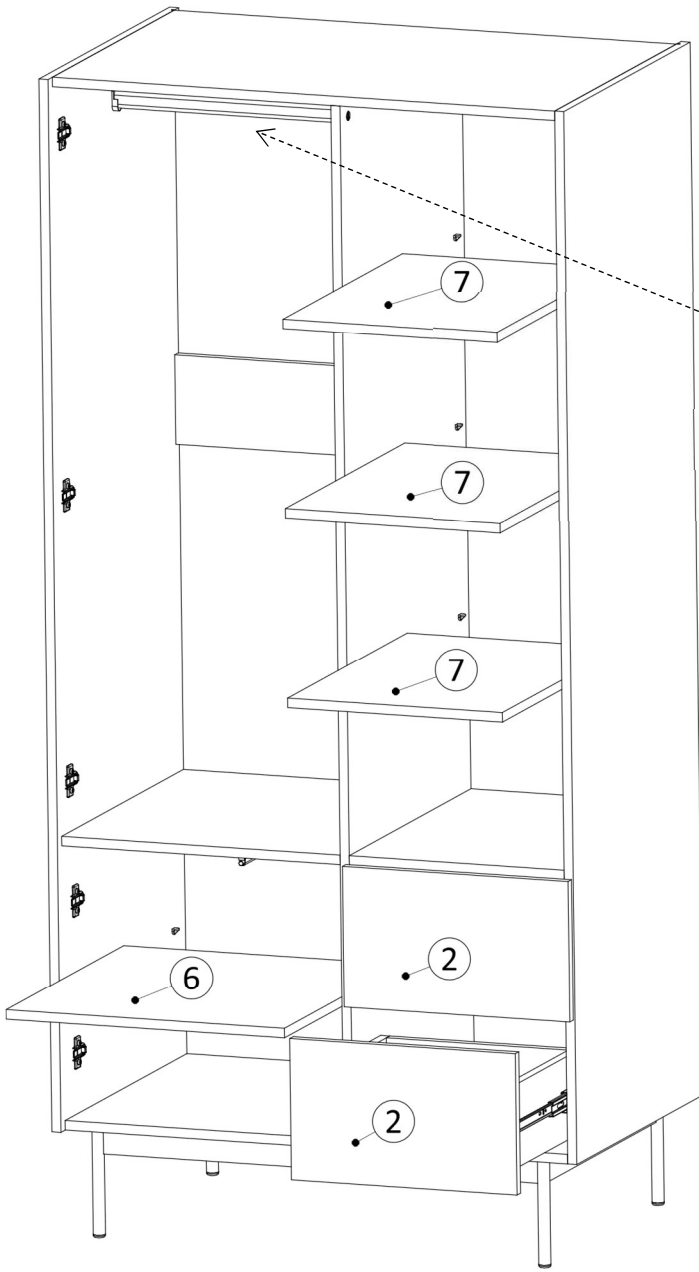

23

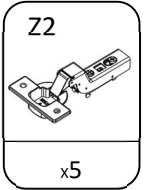
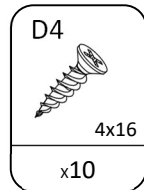
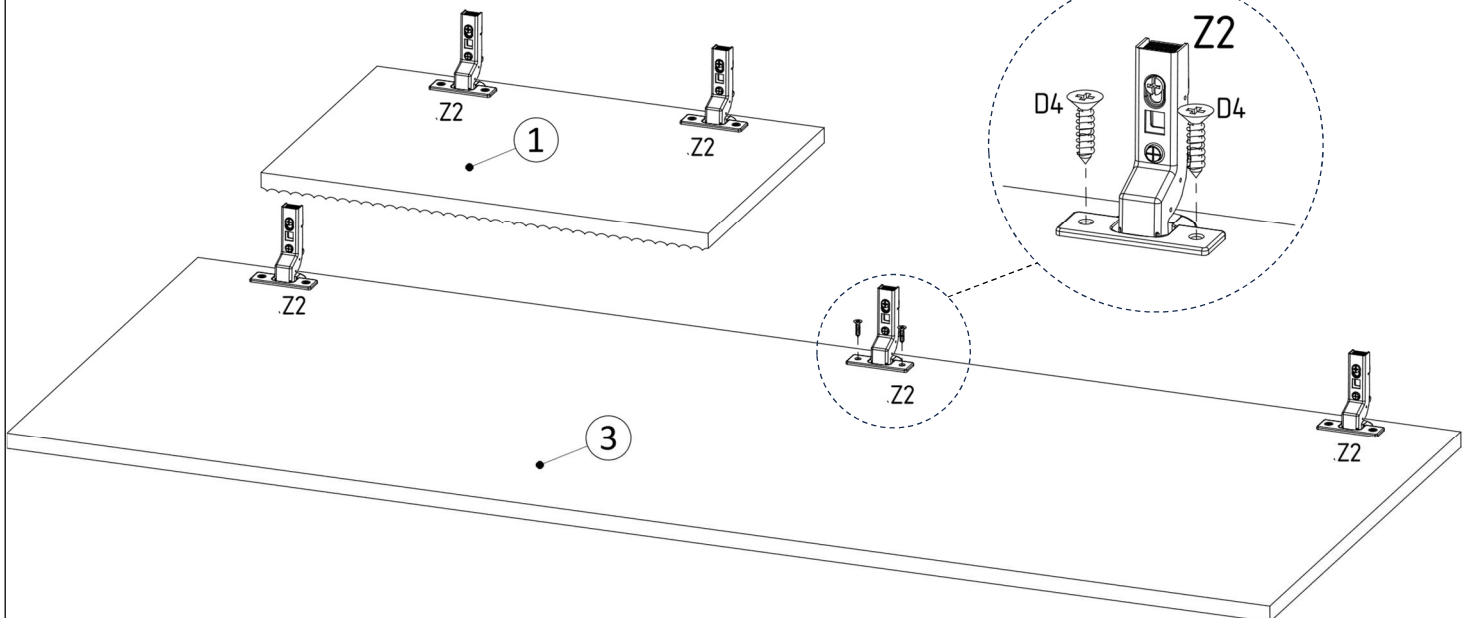

24

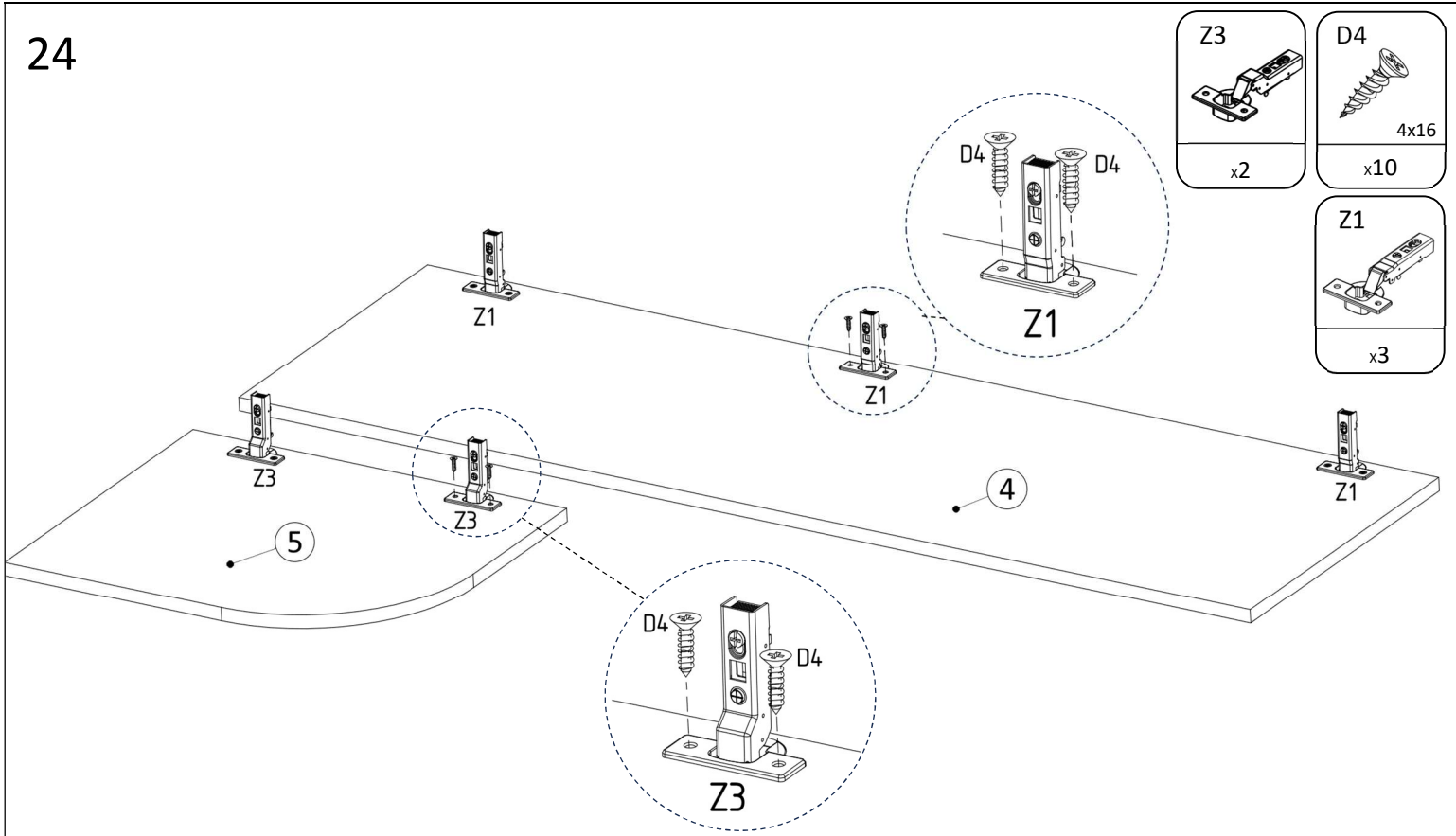

25

