

CARMEN

R-12

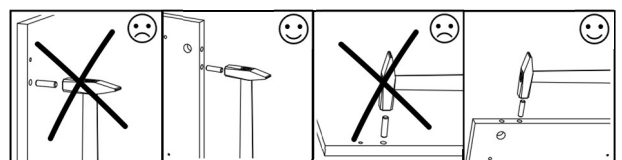

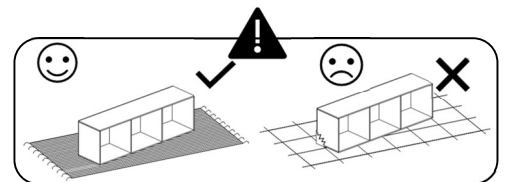
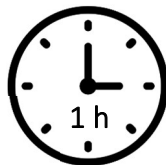
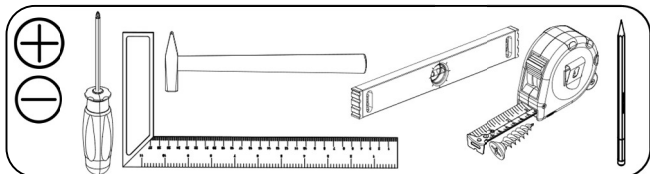
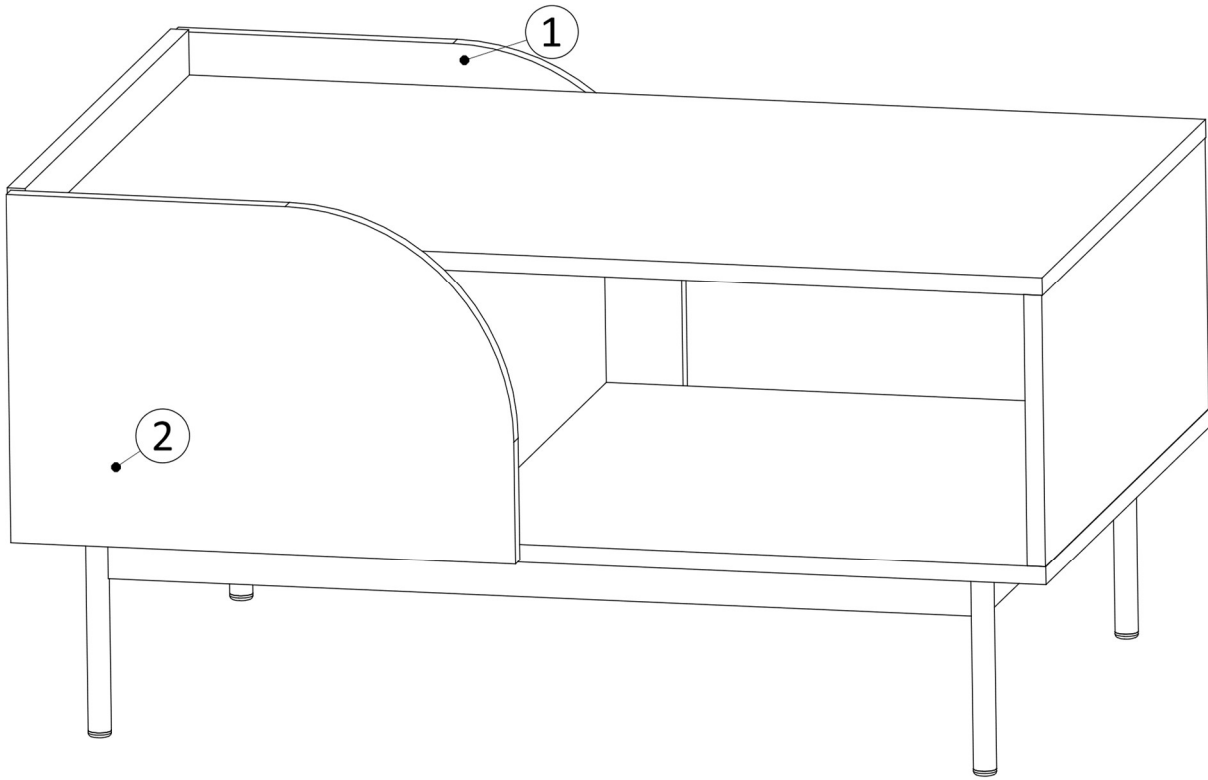
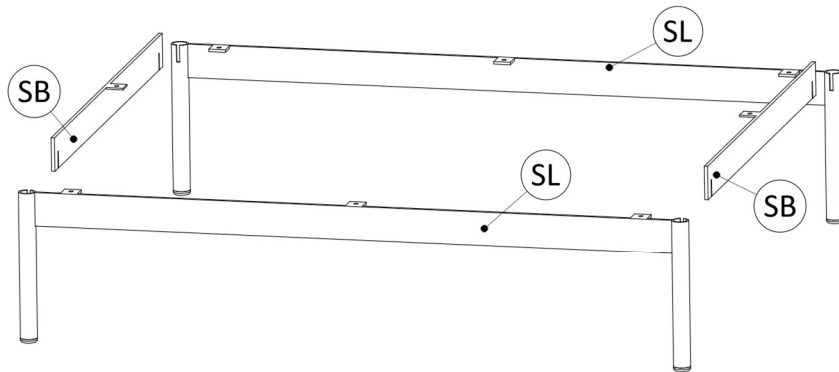
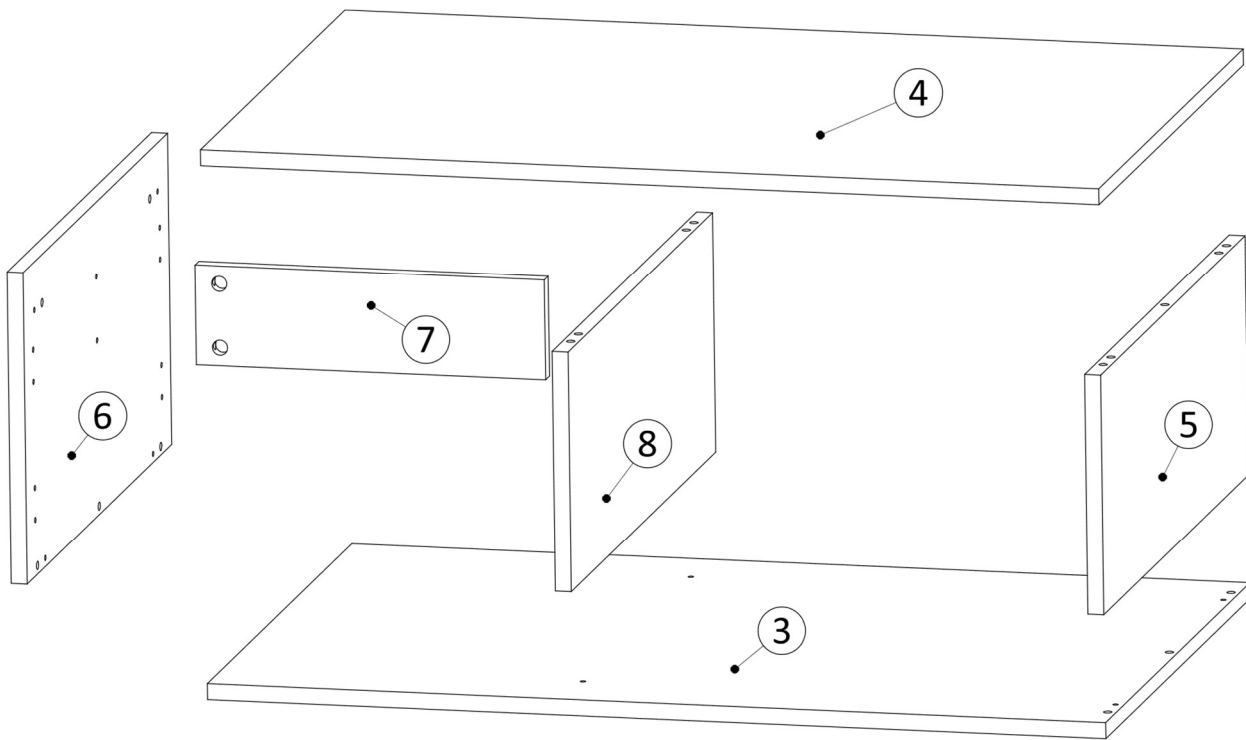

No	T(mm)	L(mm)	W(mm)	pcs.
1	16	447	308	1
2	16	447	308	1
3	16	900	600	1
4	16	900	600	1
5	16	600	240	1
6	16	600	312	1
7	16	350	100	1
8	16	600	240	1

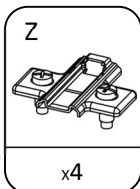
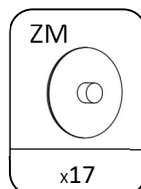
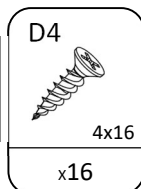
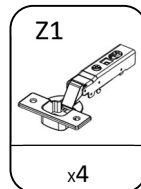
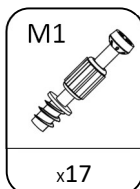
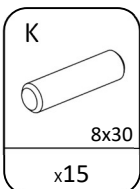
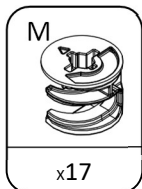

1

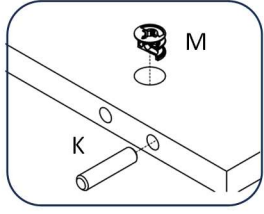
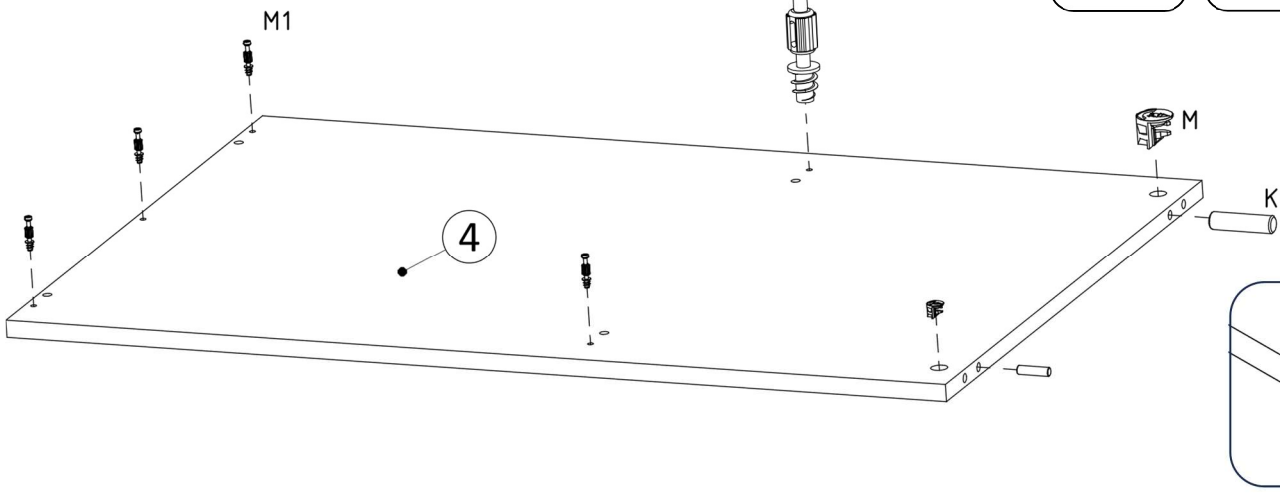
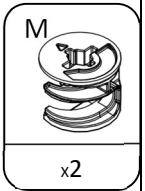
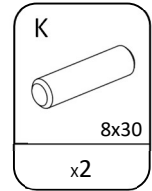
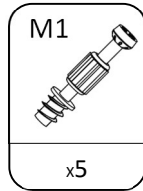
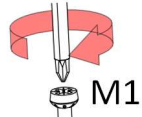
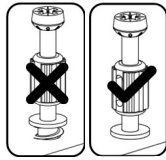

2

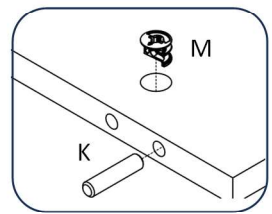
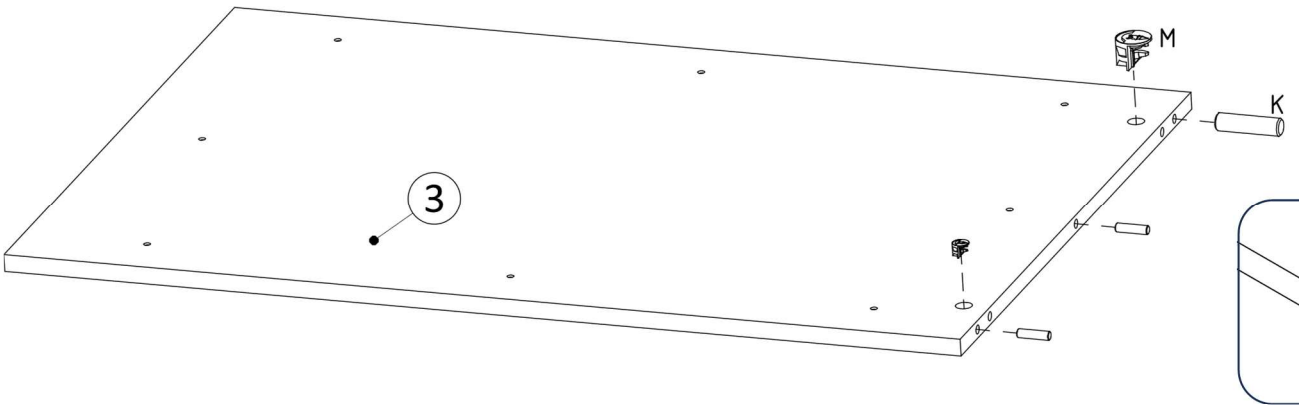
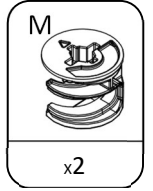
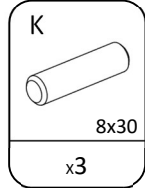

3

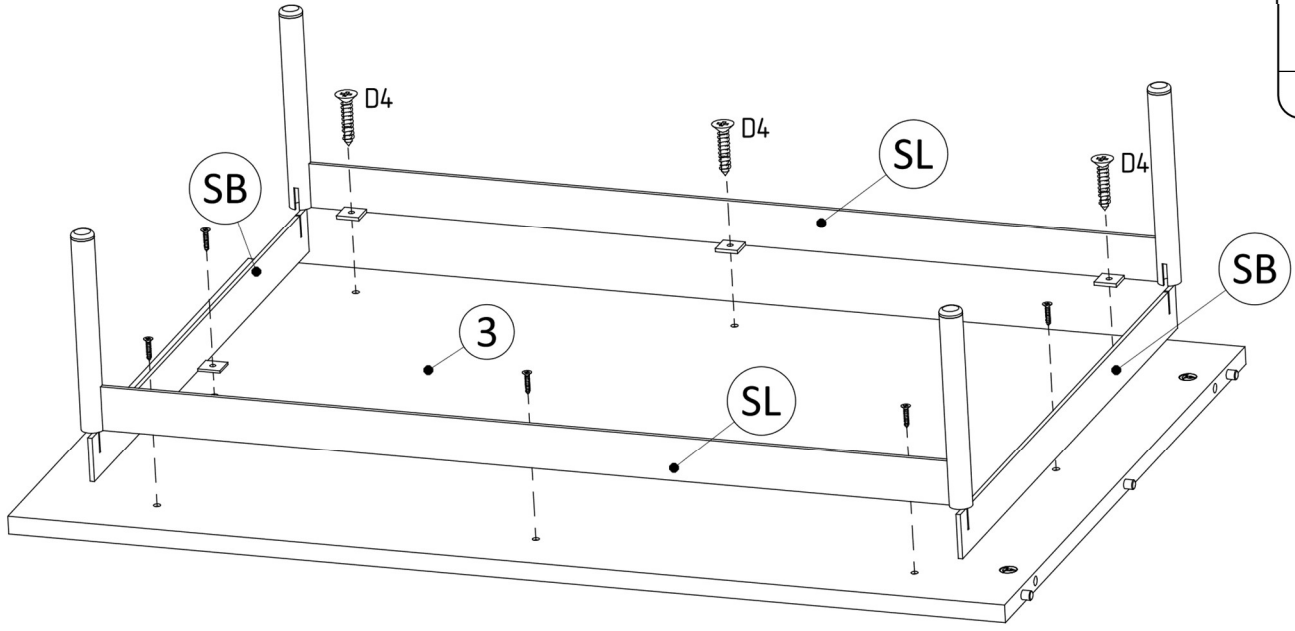
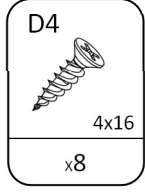

4

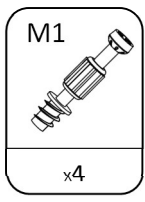
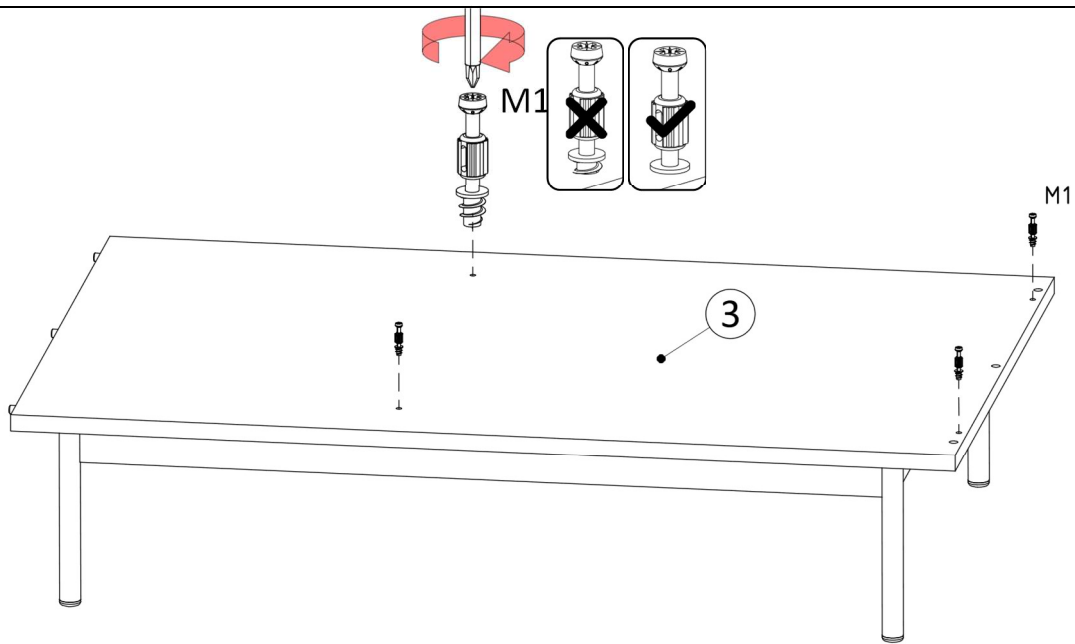

5

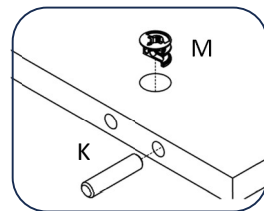
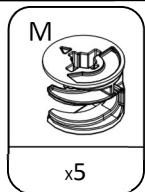
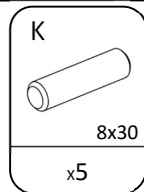
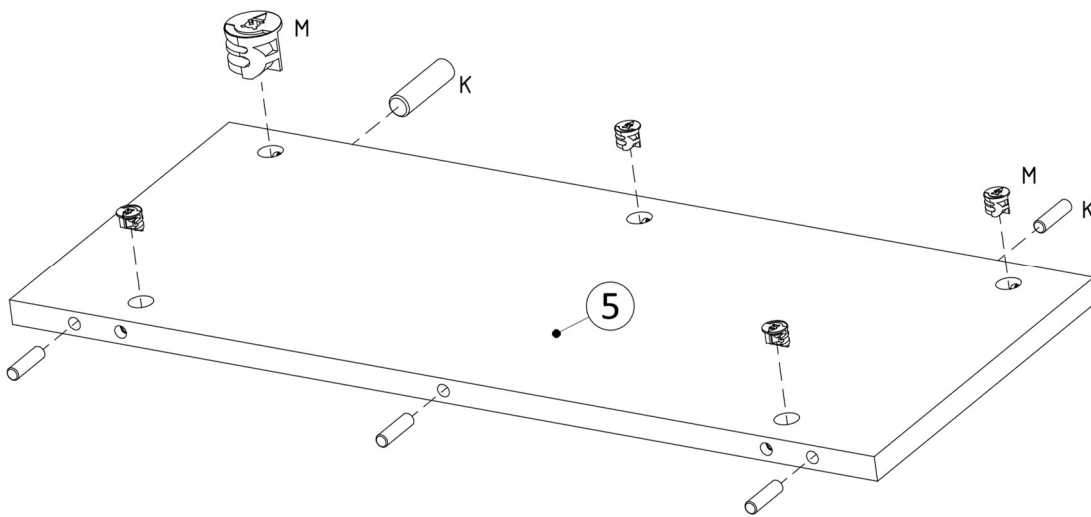

6

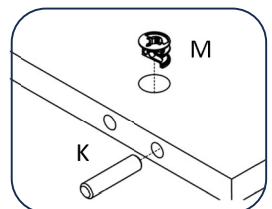
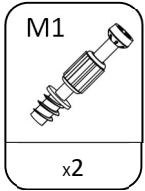
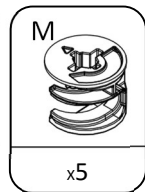
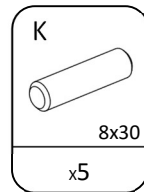
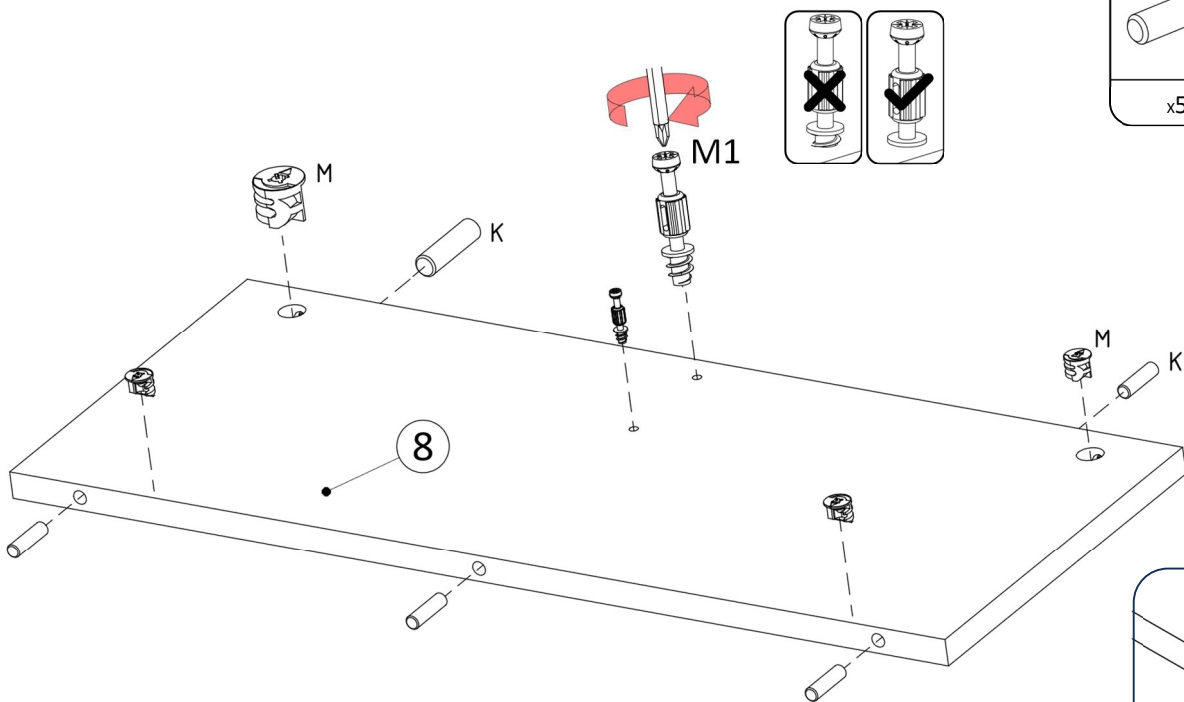

7

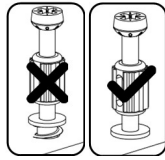
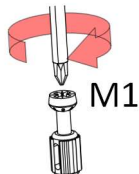

M1

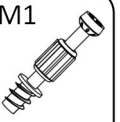

x6

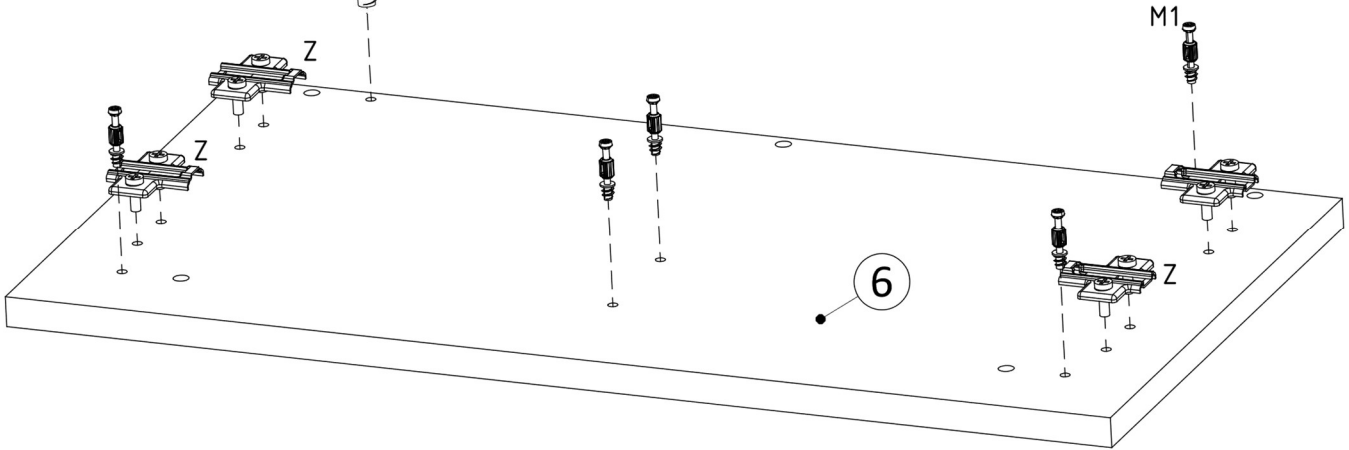

8

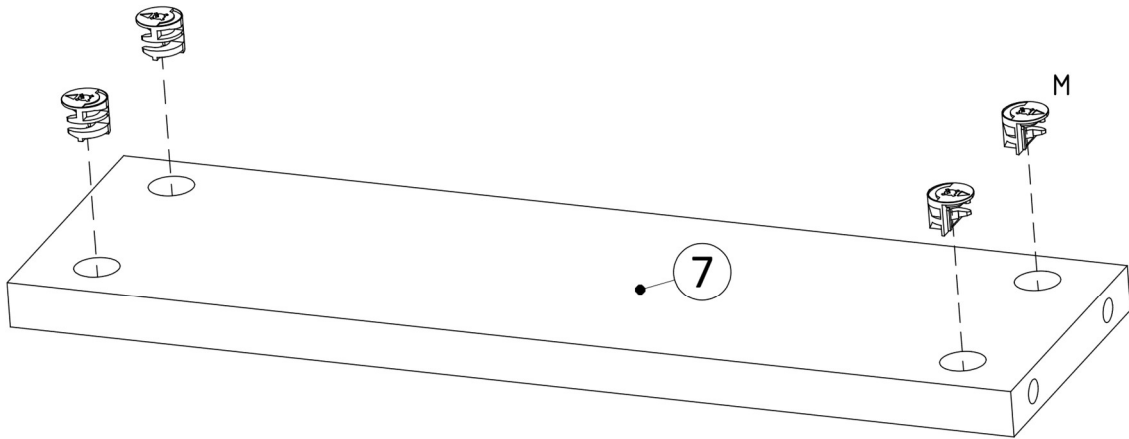

M



x4

9

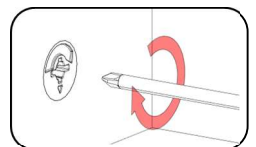
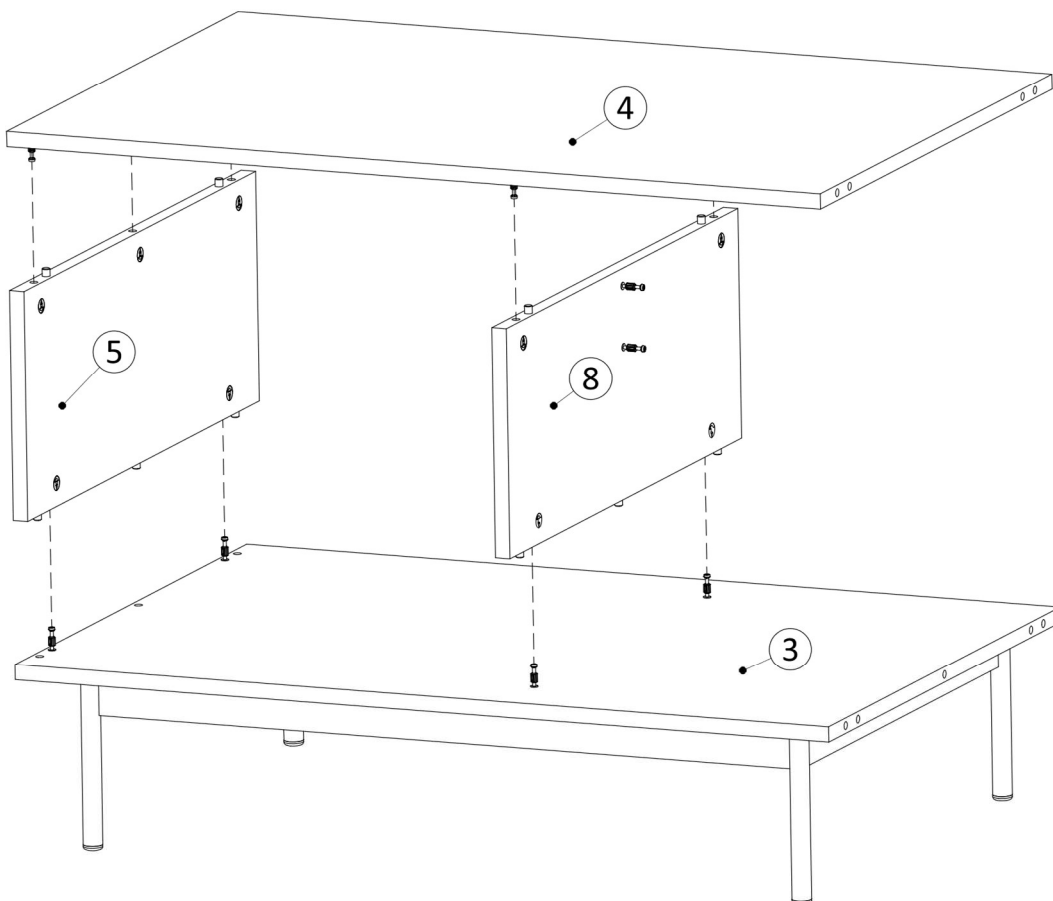

10

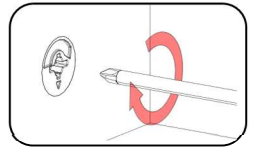
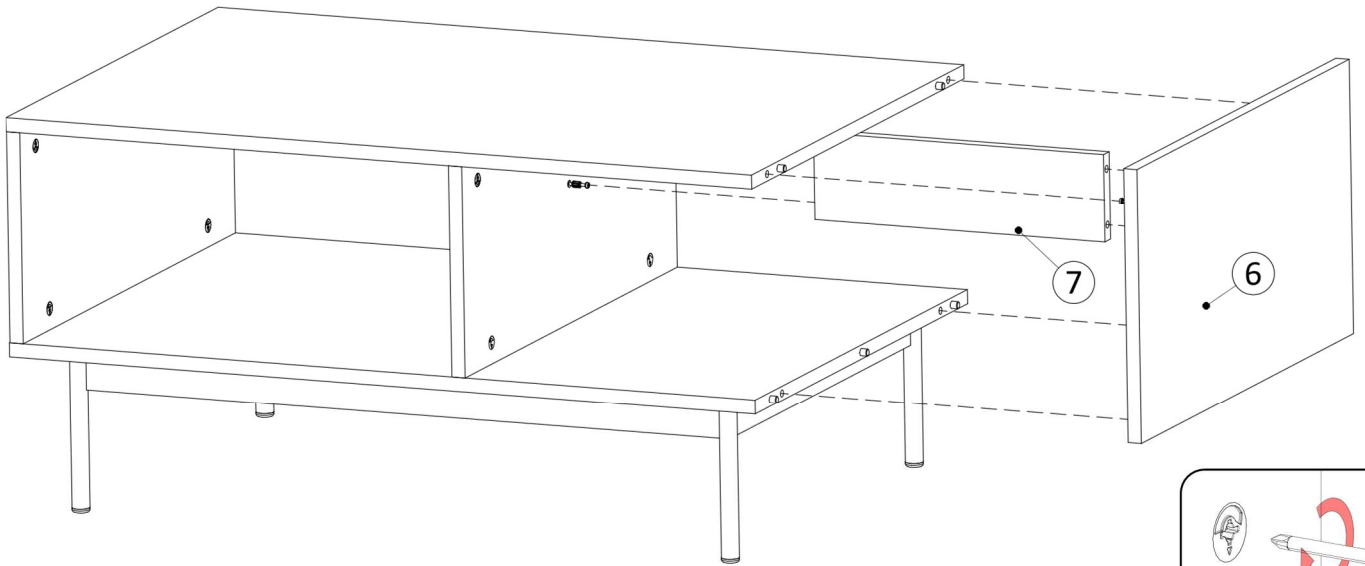

11

