

# CARMEN

R-11

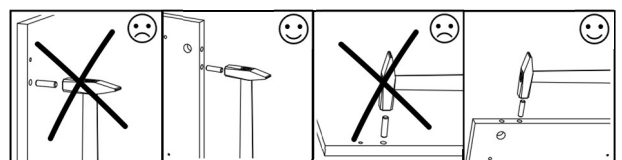

No	T(mm)	L(mm)	W(mm)	pcs.
1	18	132	209	1
2	16	545	160	1
3	16	545	160	1
4	16	468	110	1
5	16	375	110	1
6	16	420	204	1
7	16	350	110	2
8	16	400	204	1
9	16	1184	187	1
10	16	365	132	1
11	16	383	132	1
12	16	1184	400	1
13	16	1184	383	1
15	3	388	346	1
16	3	481	346	1
17	16	350	110	2

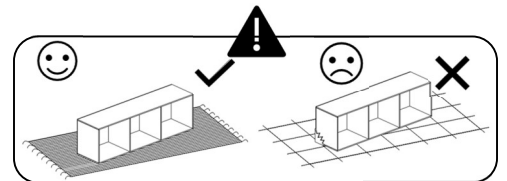
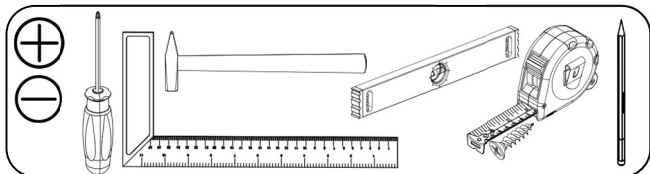
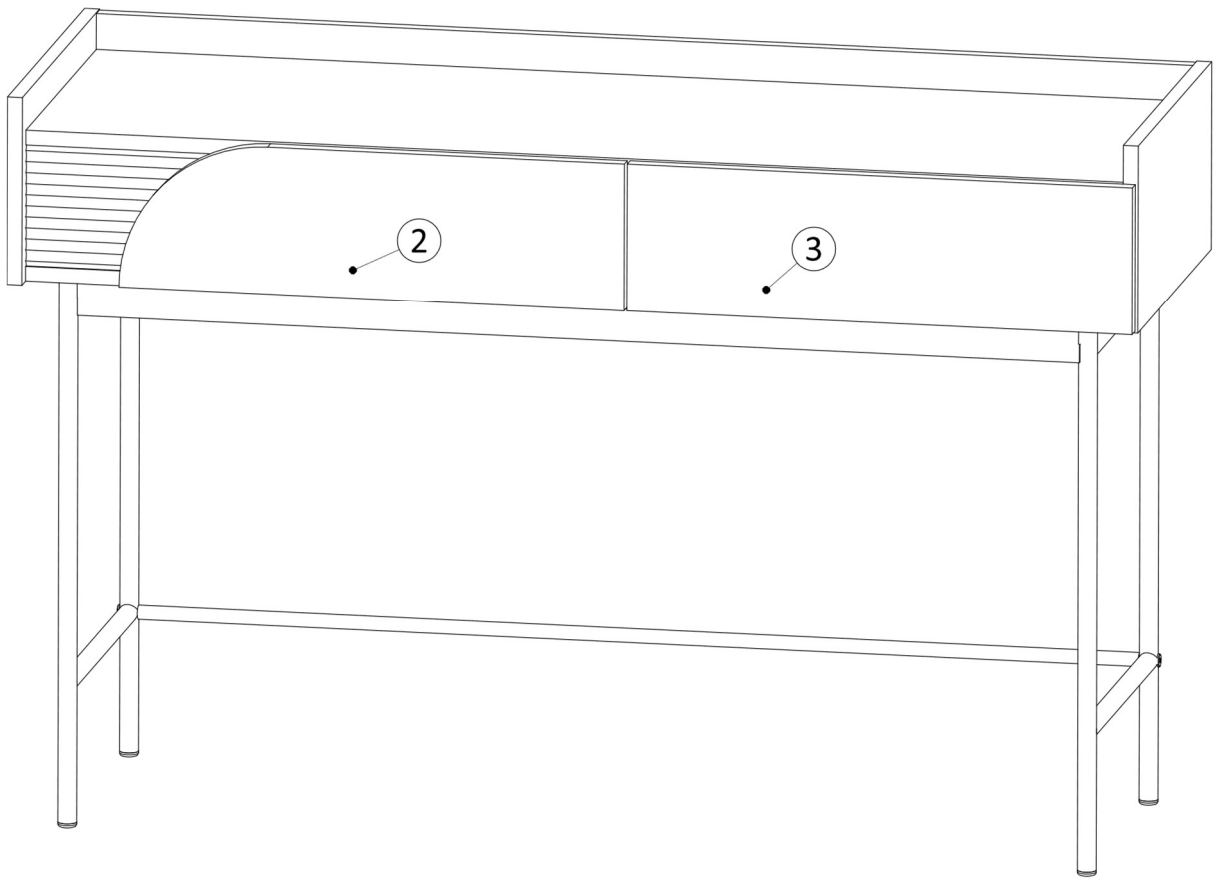
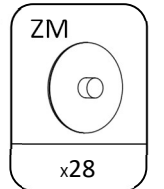
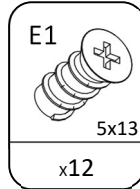
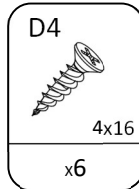
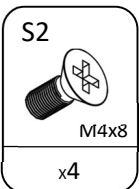
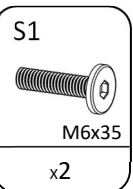
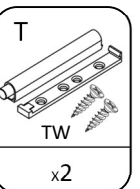
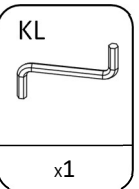
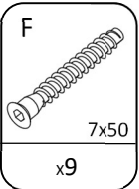
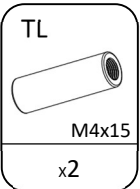
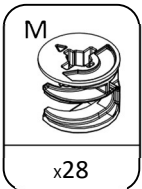
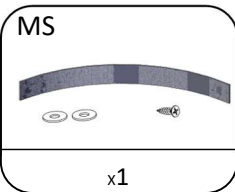
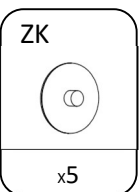
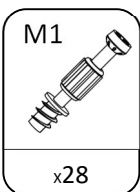
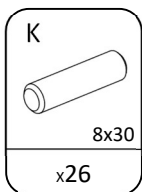
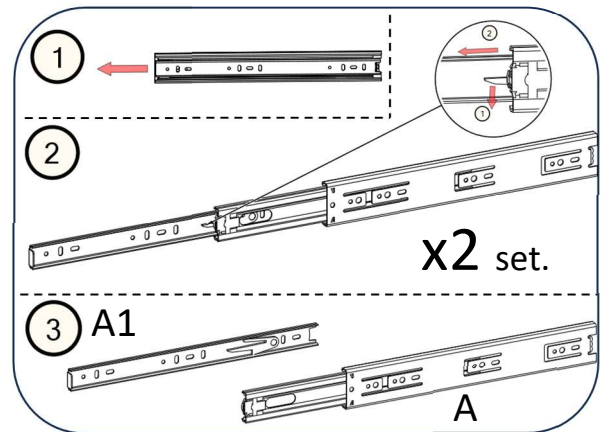
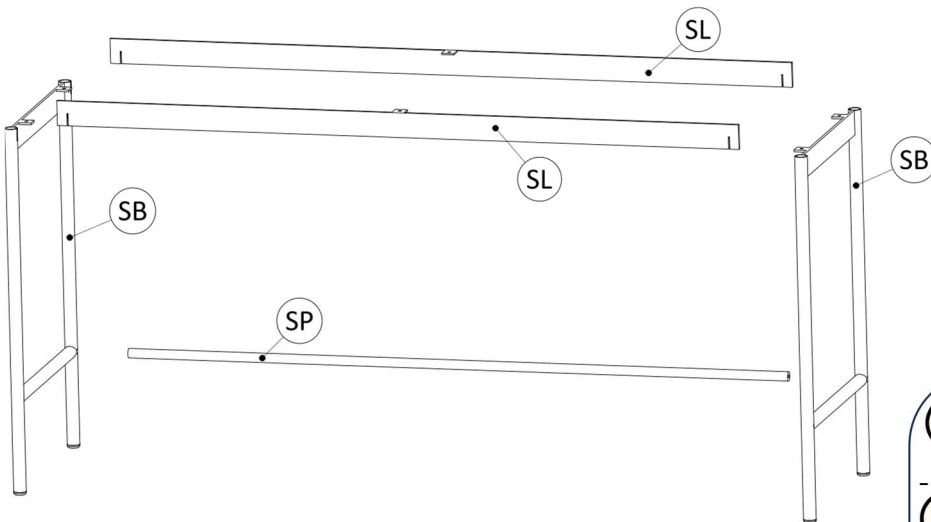
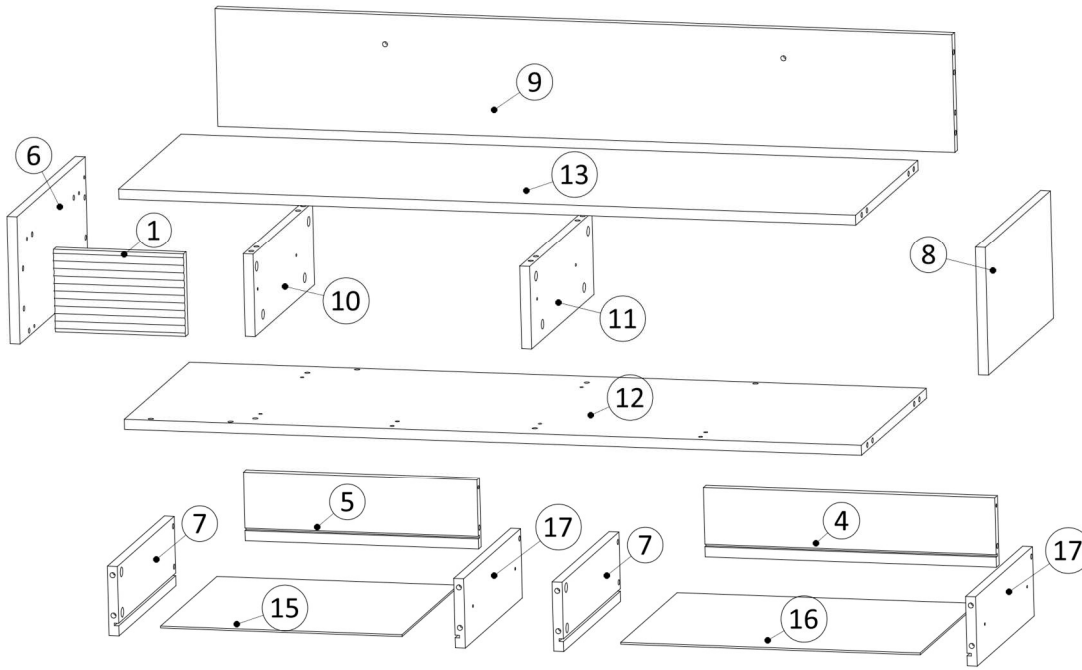

1

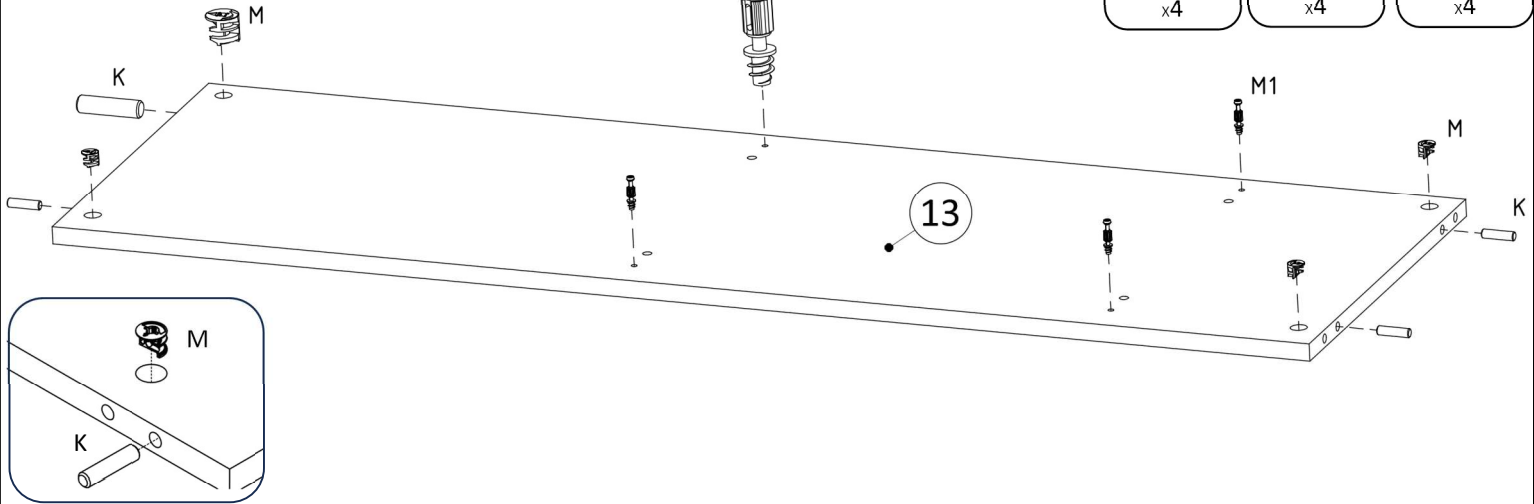
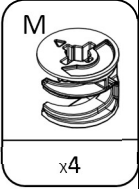
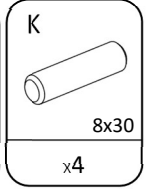
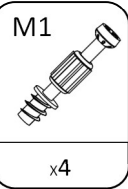
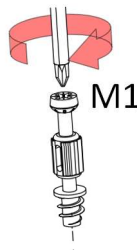
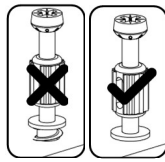

2

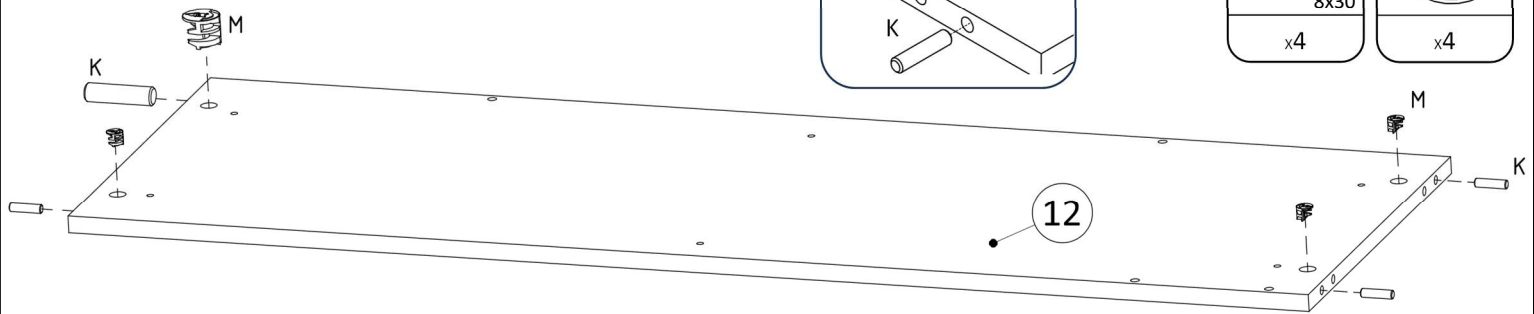
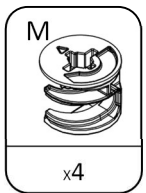
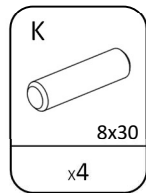
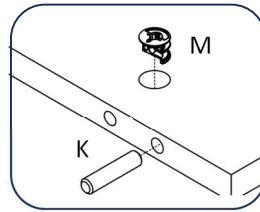

3

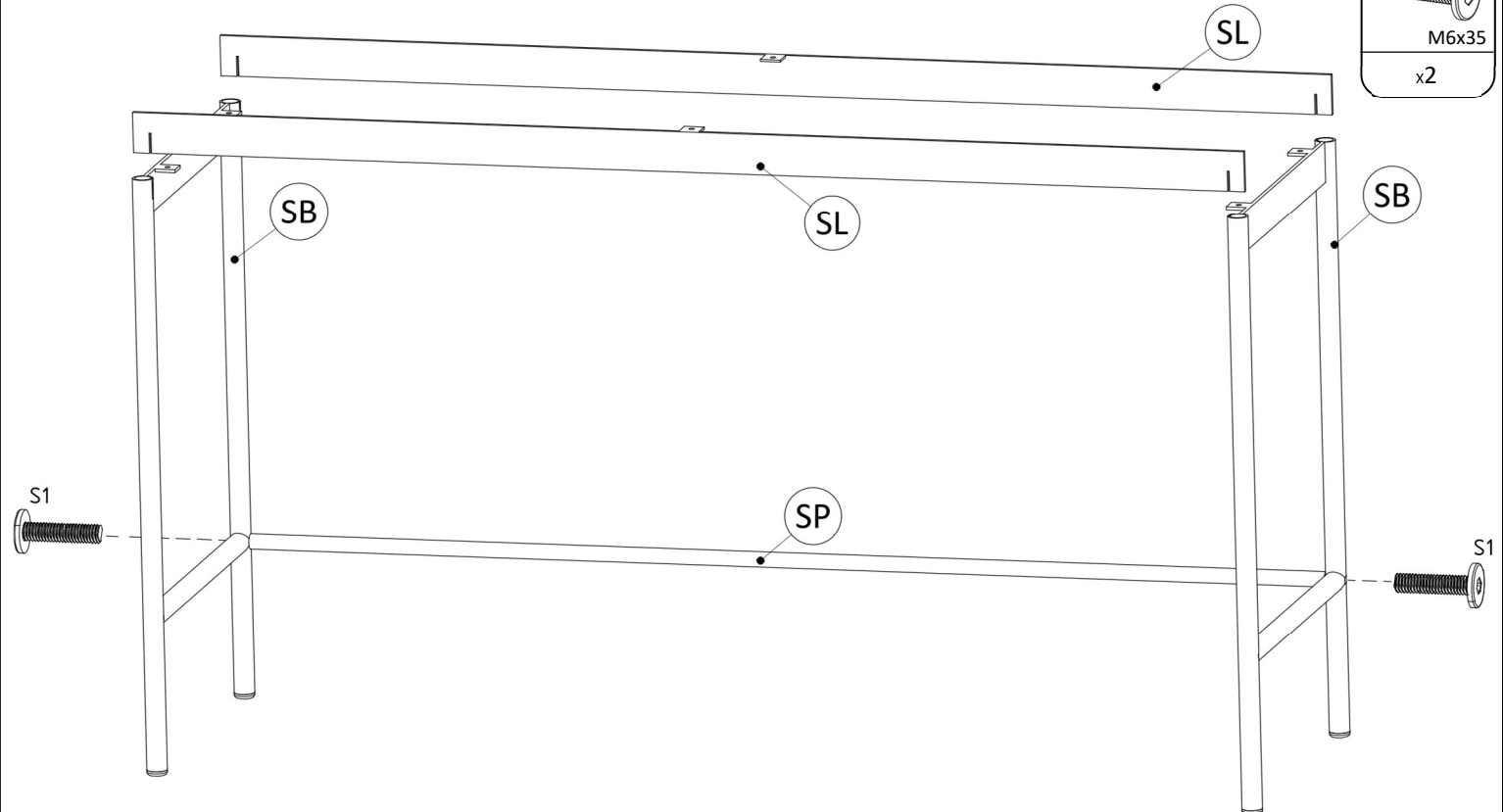
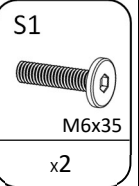

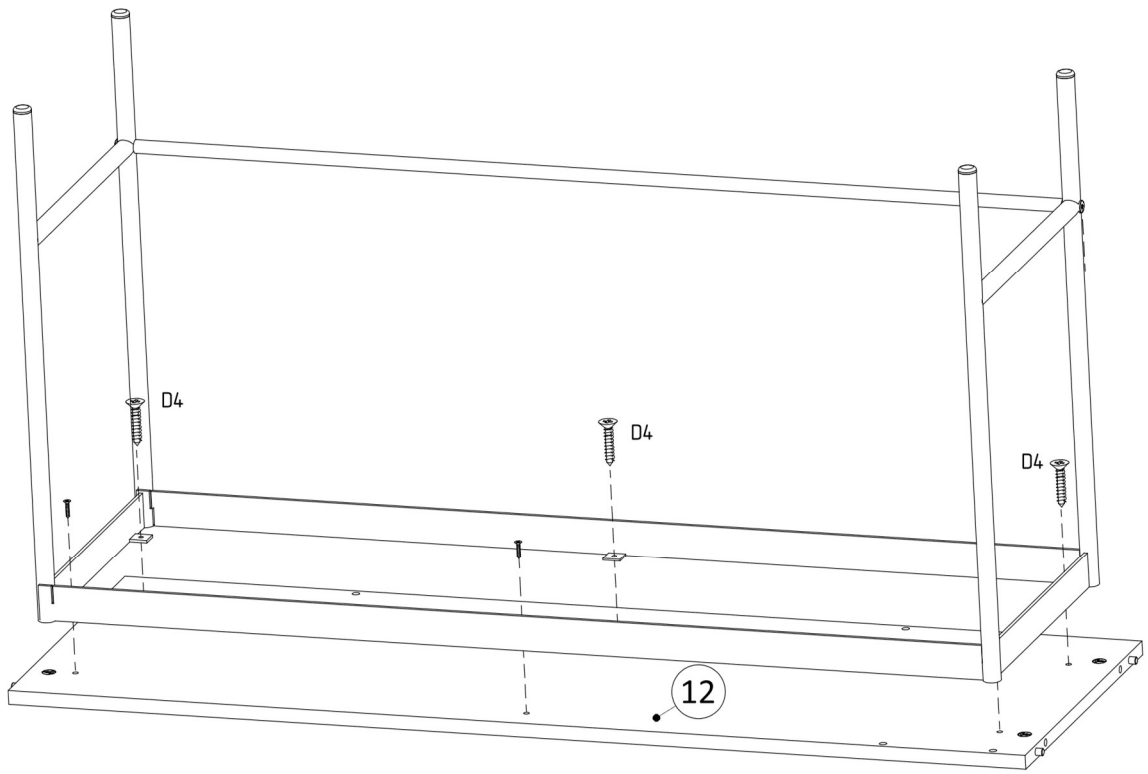

4

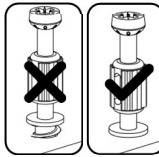

D4

4x16
x6

5

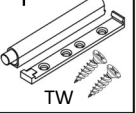

M1

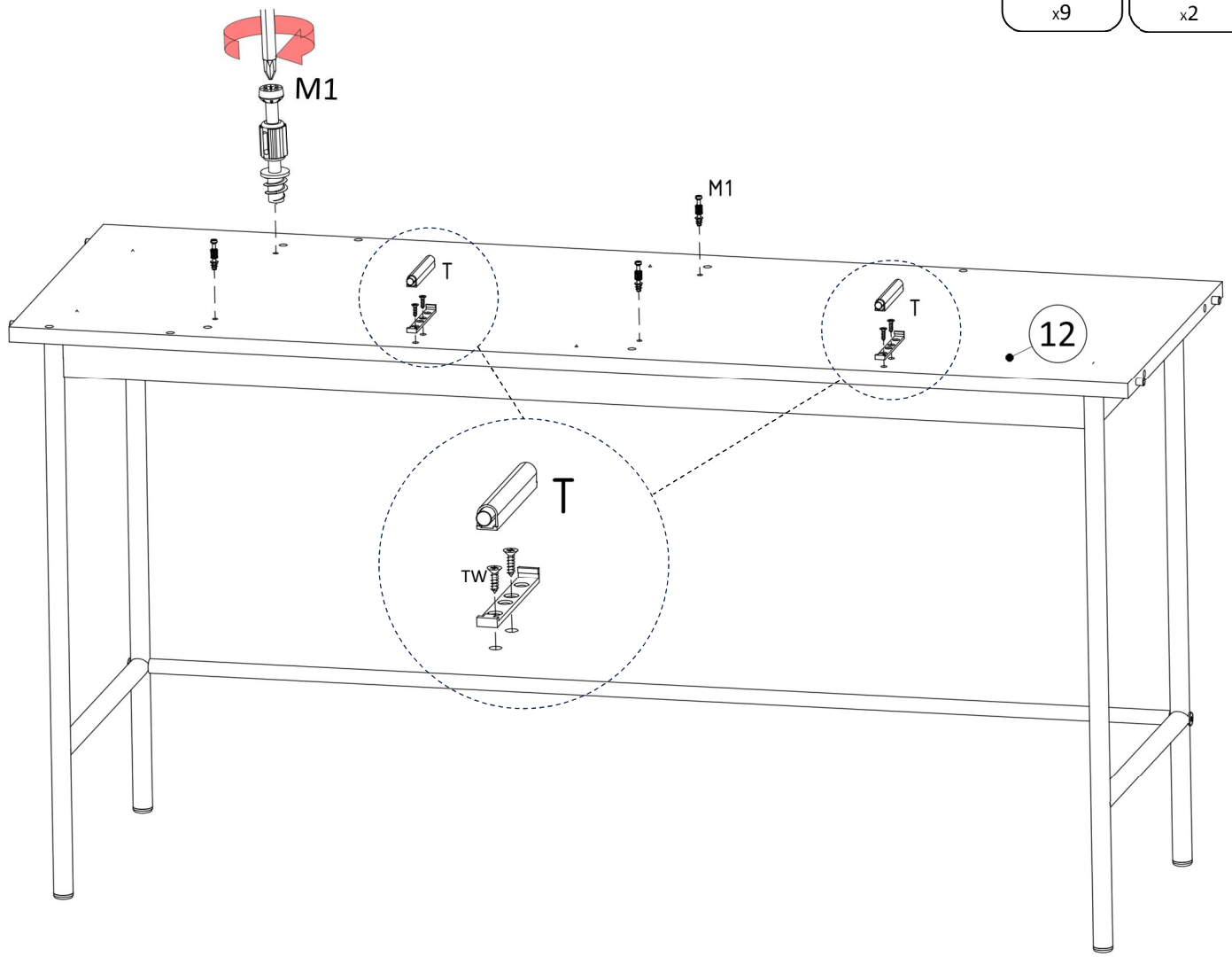
x9

T

TW
x2

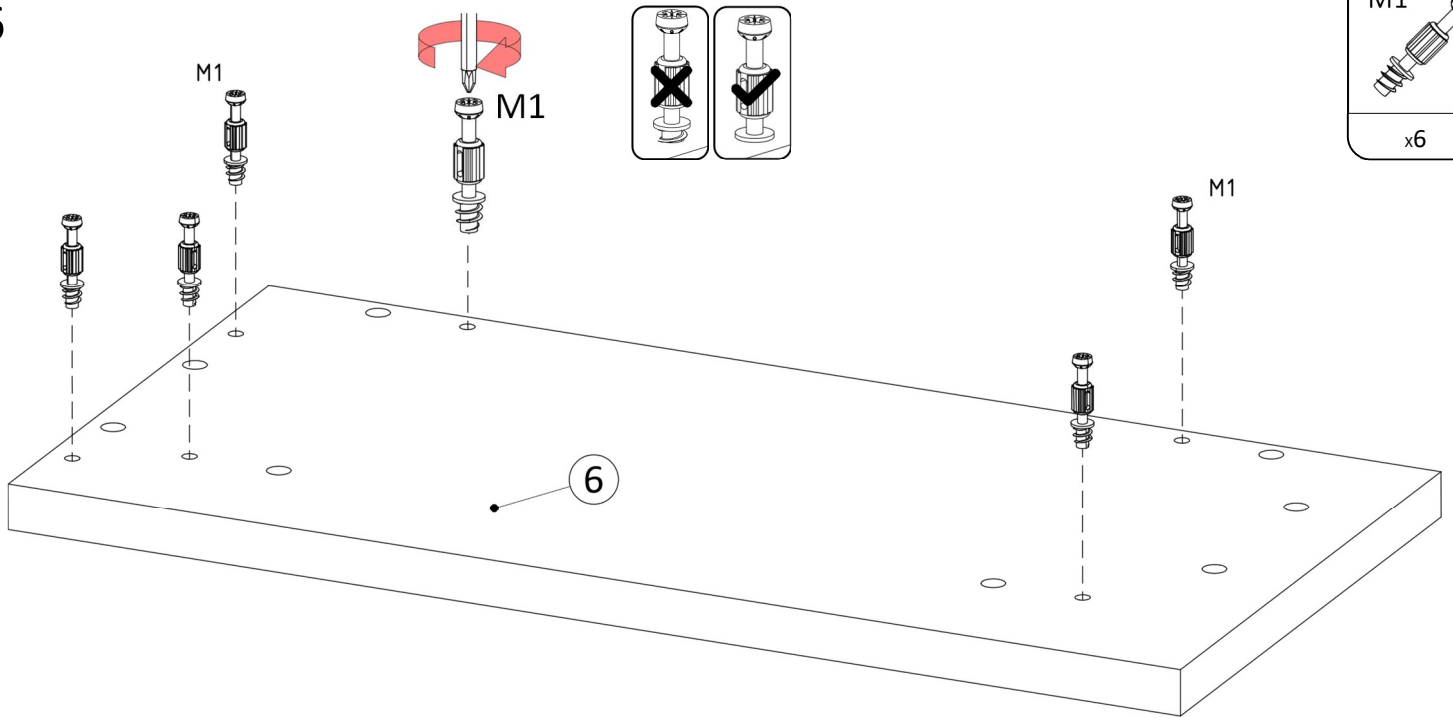

6

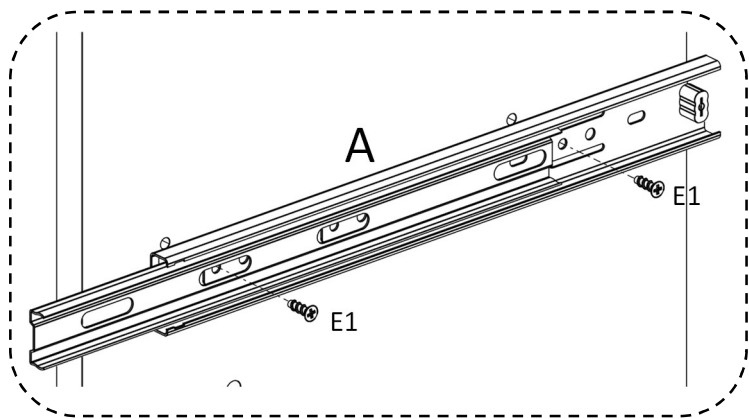
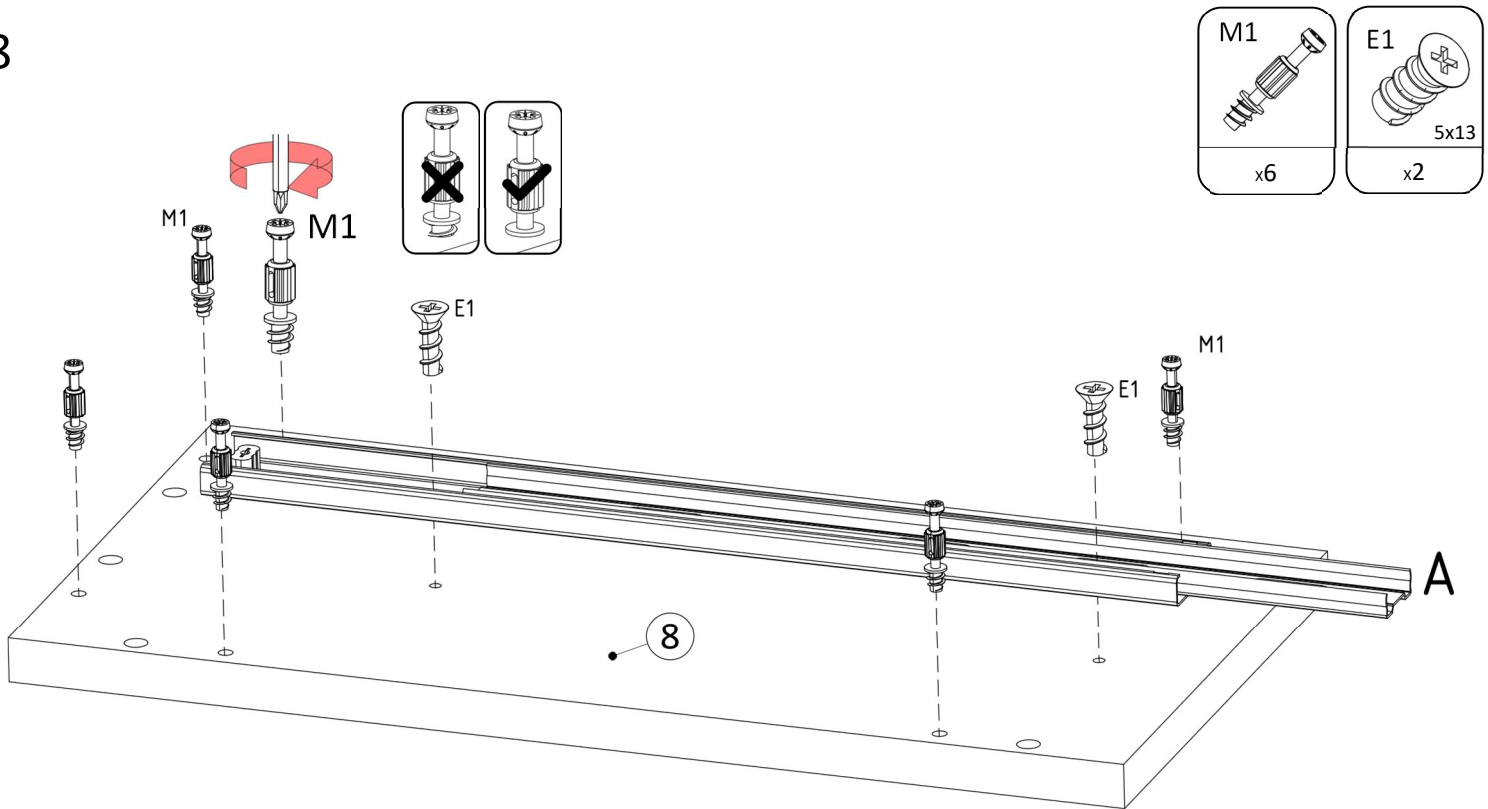

8



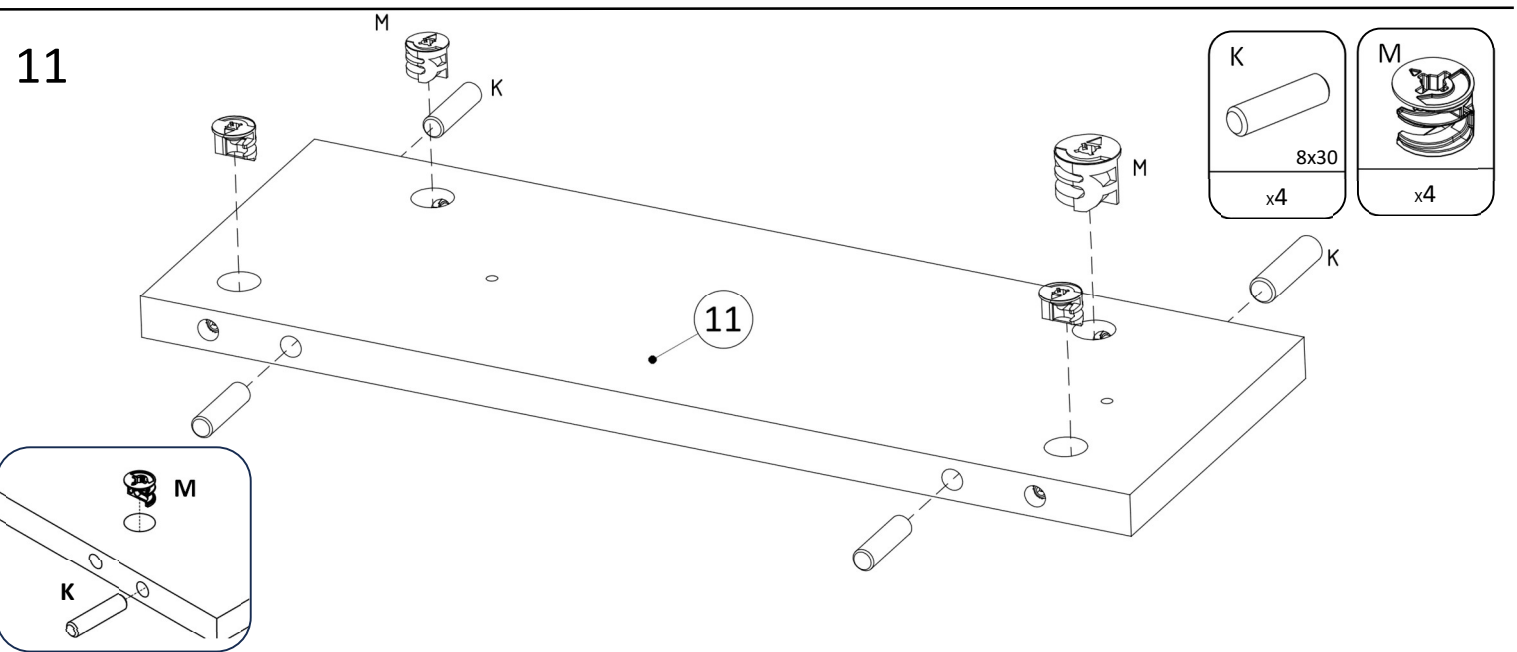
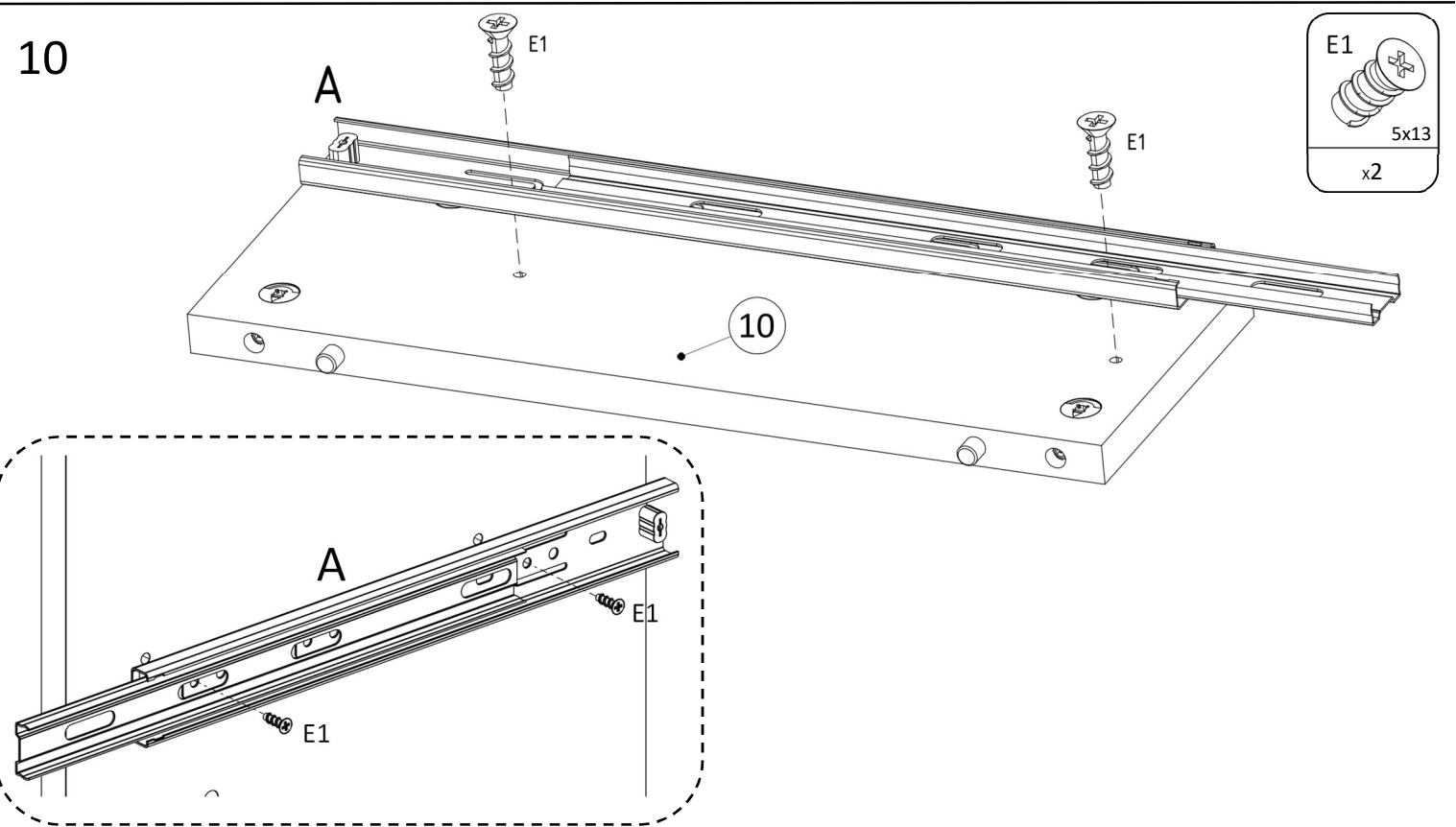
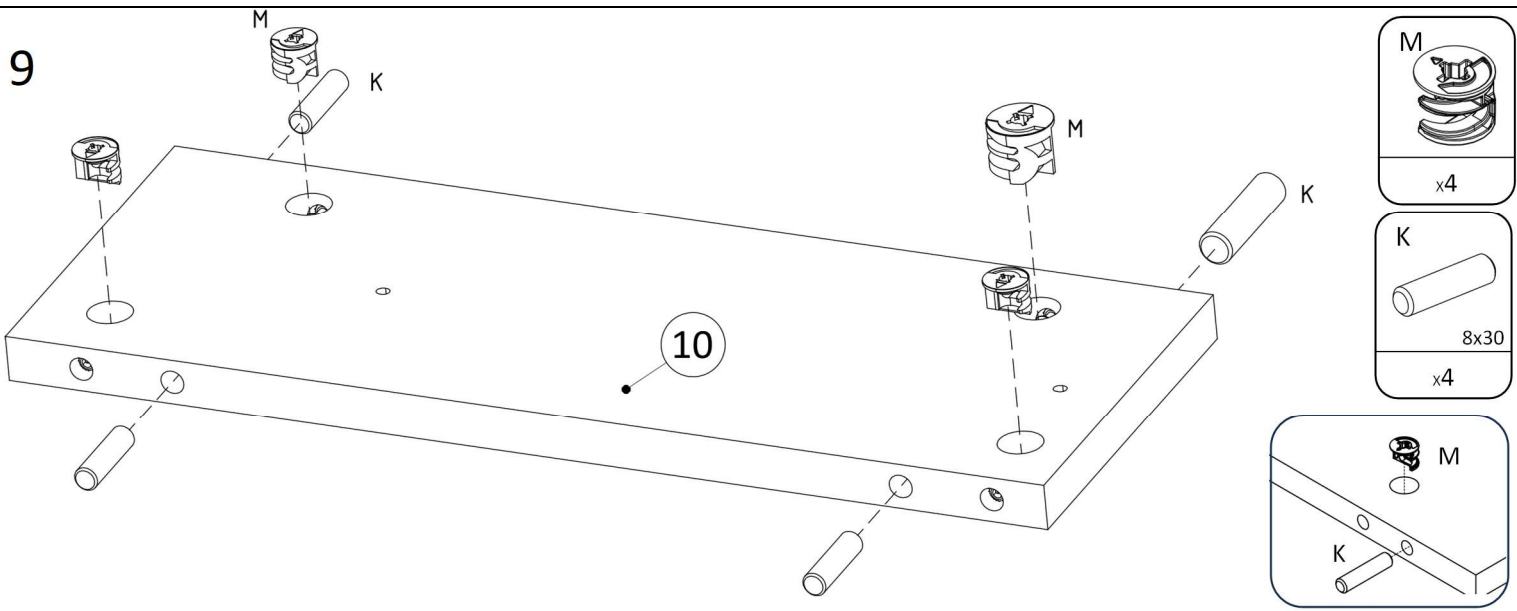

12

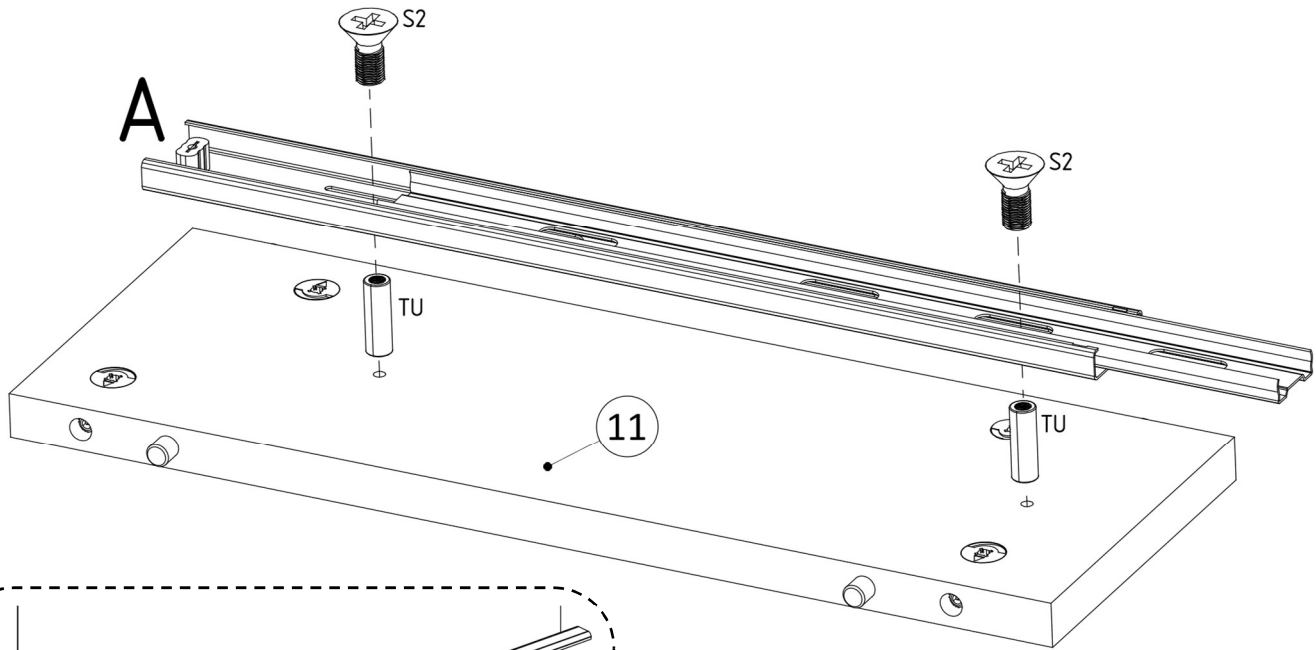

S2



M4x8

x2

TL



M4x15

x2

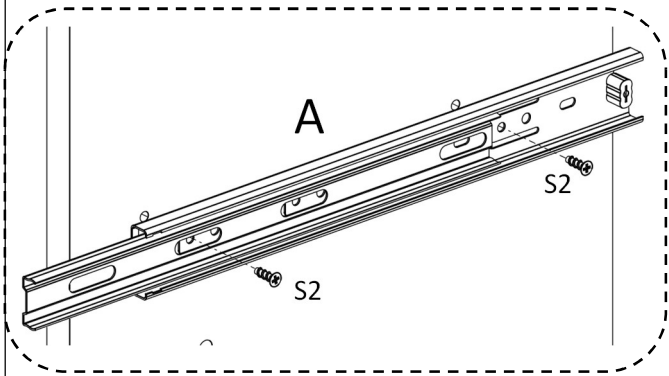

13

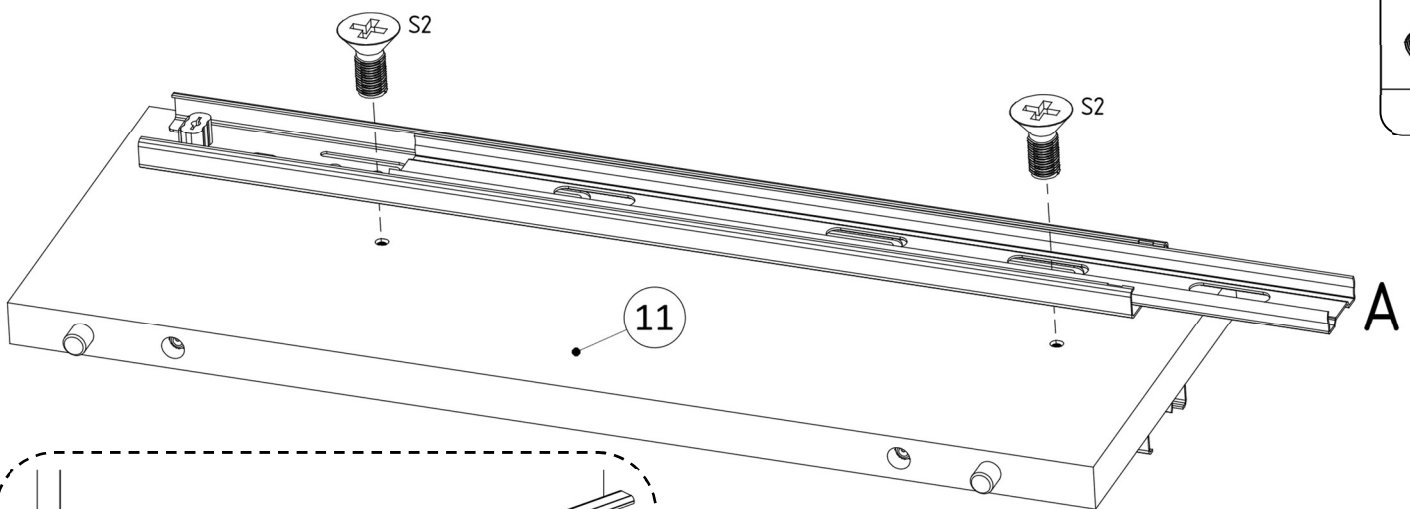

S2



M4x8

x2

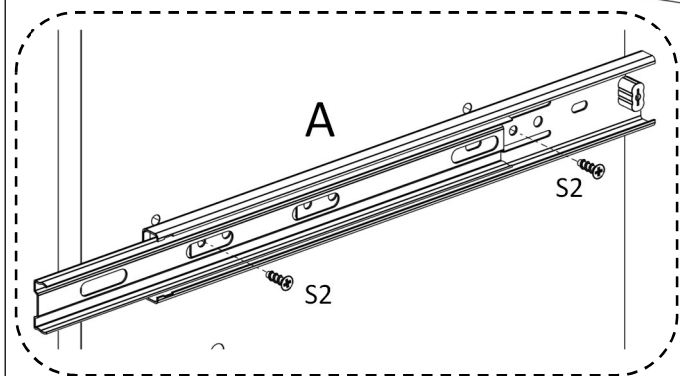

14

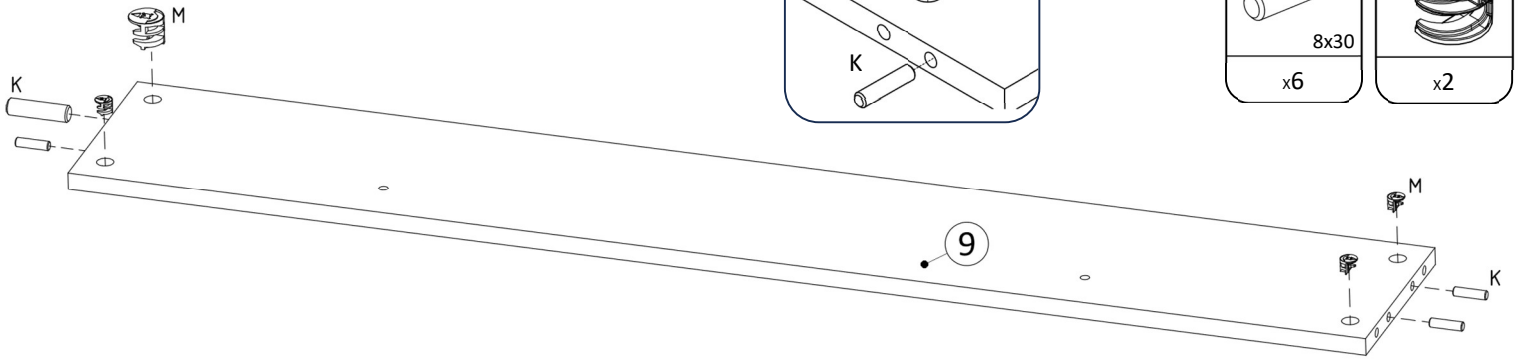

15

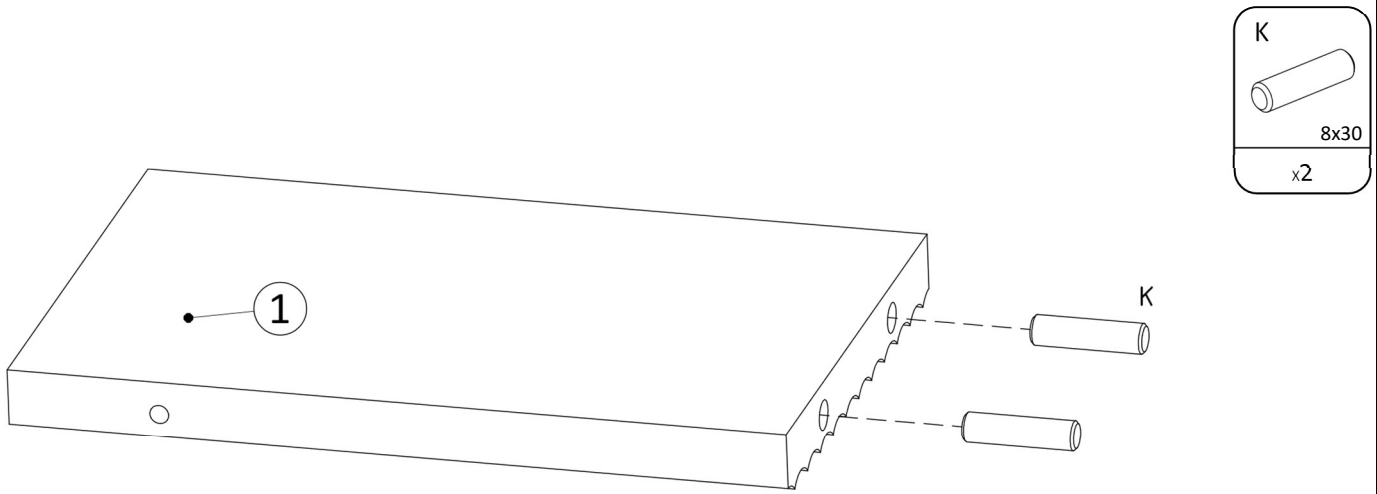

16

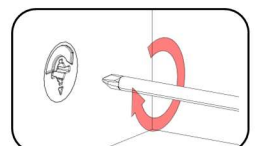
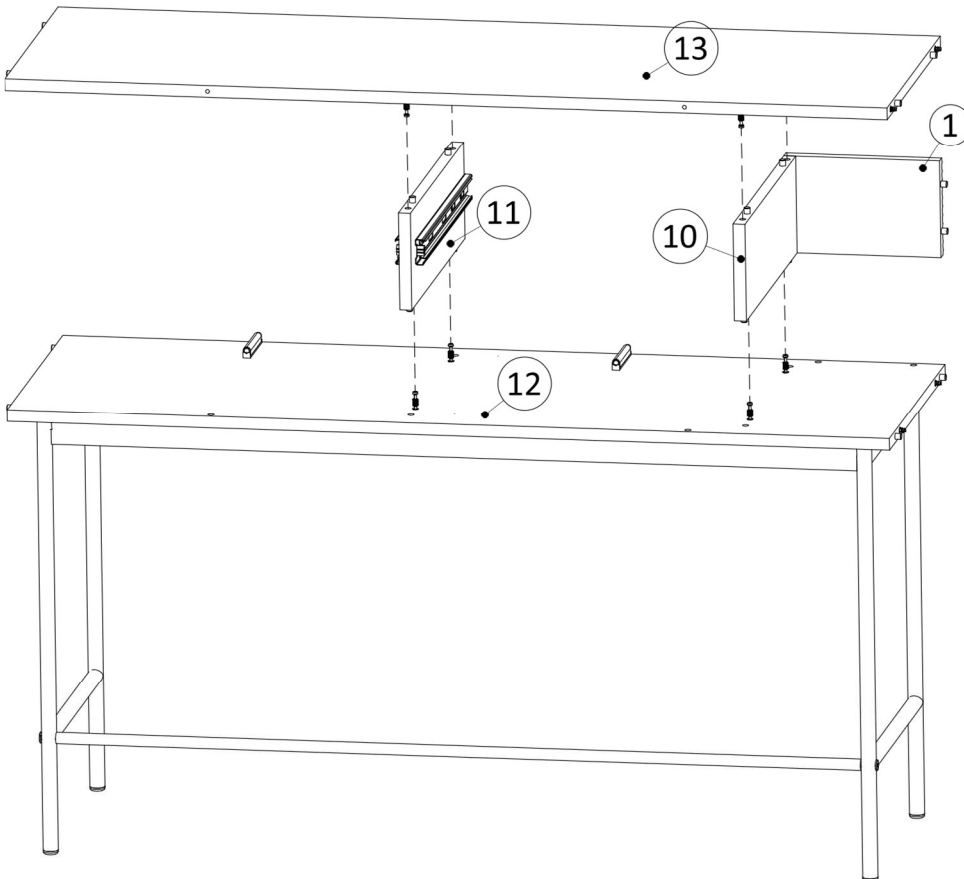

17

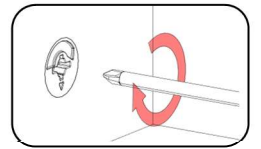
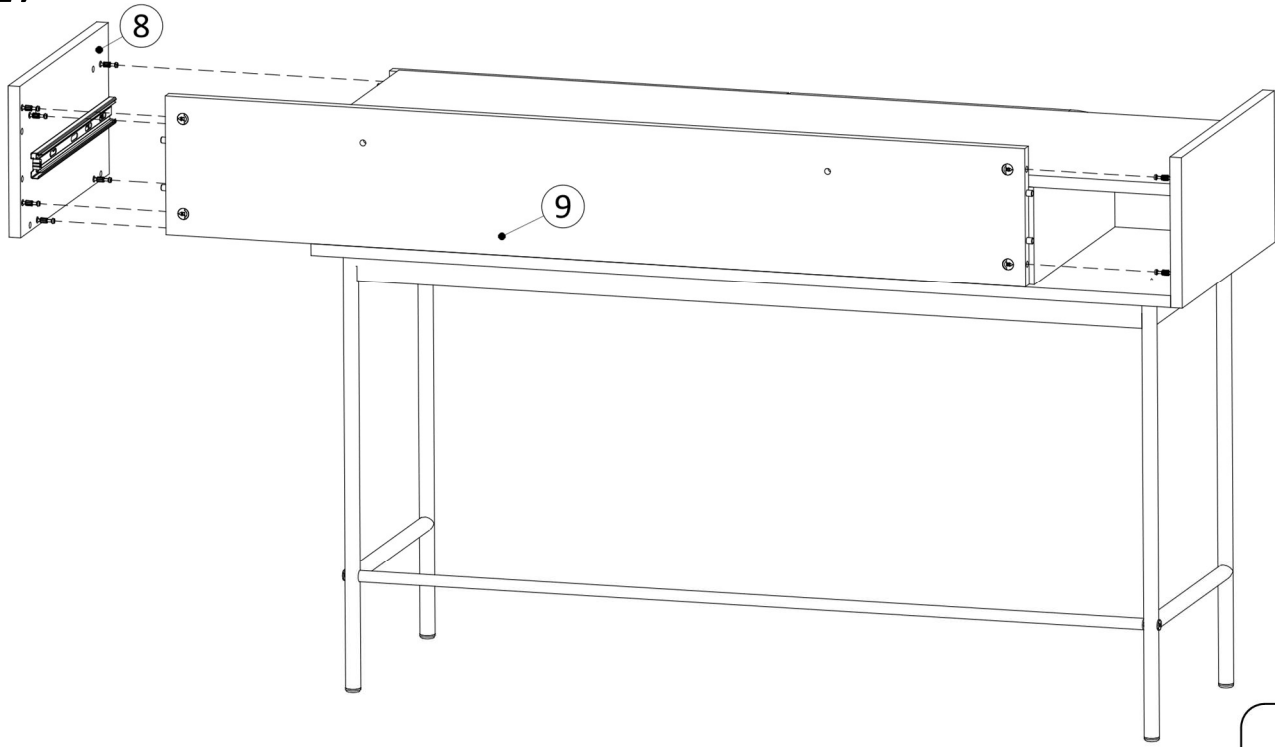

18

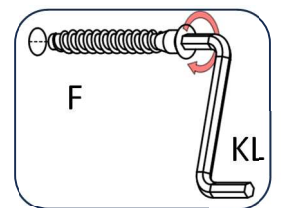
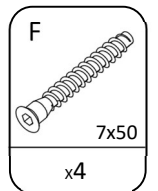
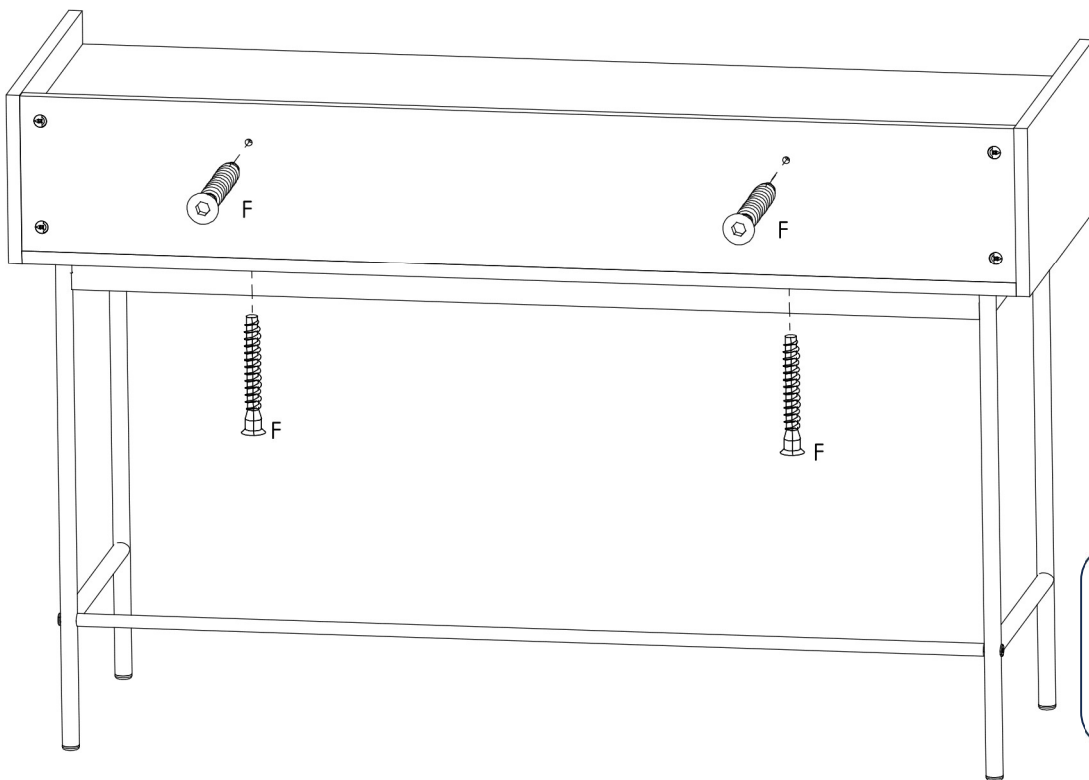

19

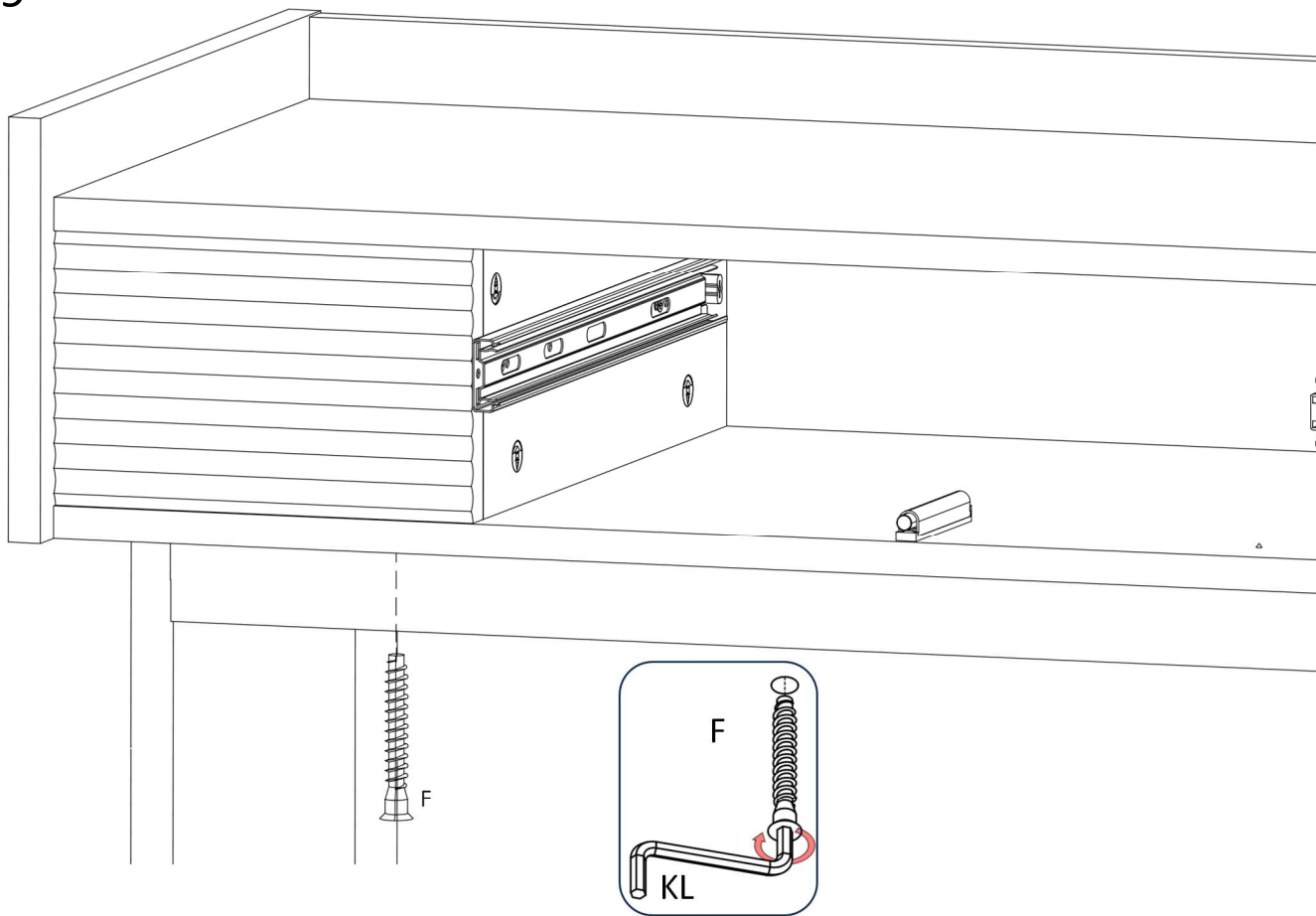

F
7x50
x1

20

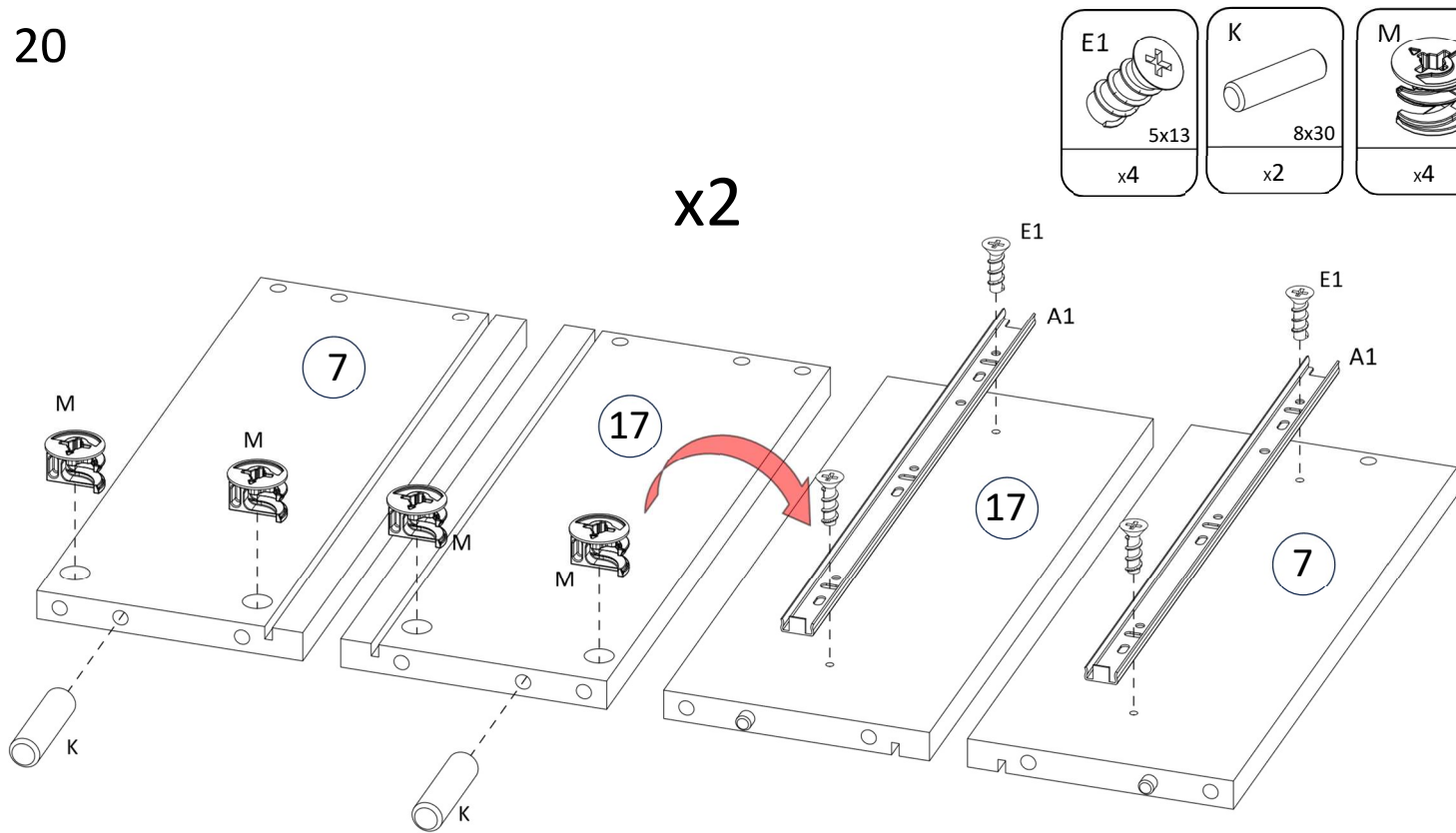

E1
5x13
x4

K
8x30
x2

M
x4

x2



