

CARMEN

R-10

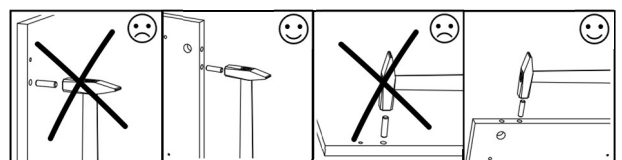

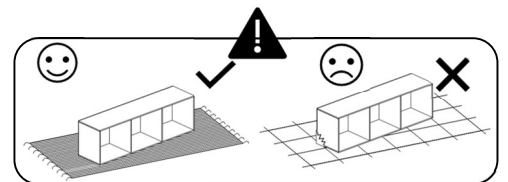
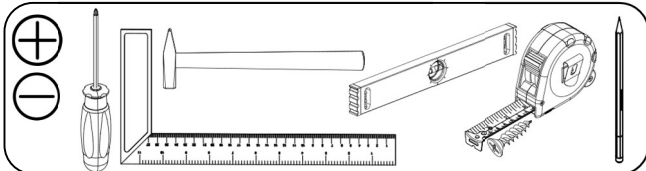
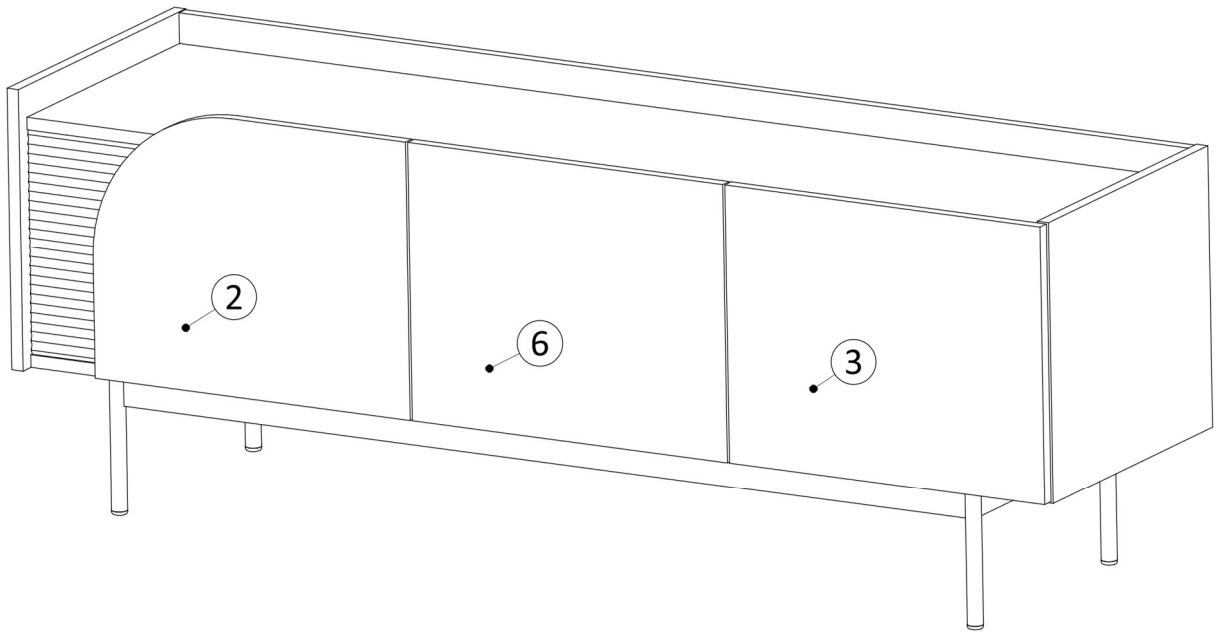
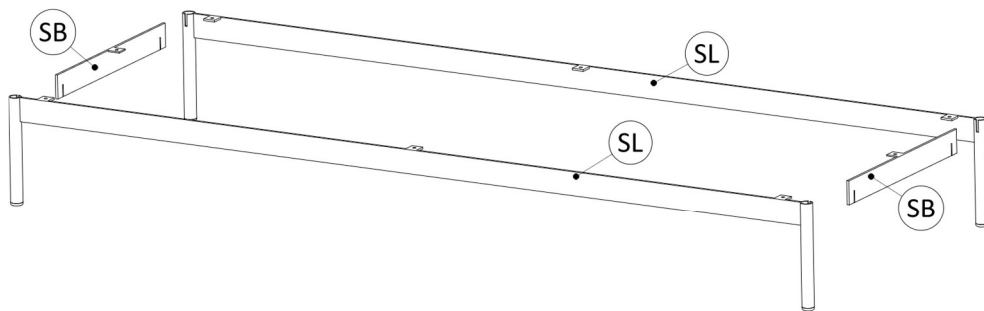
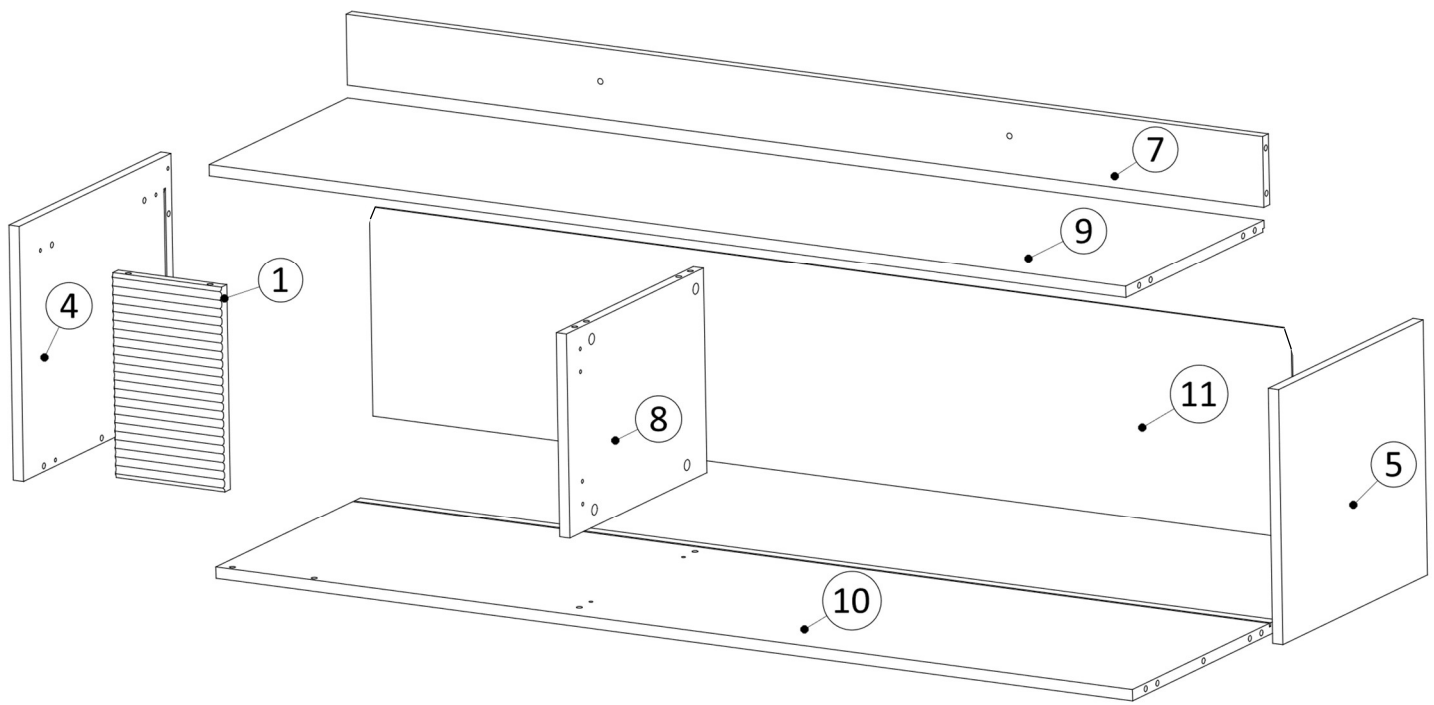

No	T(mm)	L(mm)	W(mm)	pcs.
1	18	288	170	1
2	16	447	356	1
3	16	447	356	1
4	16	420	360	1
5	16	400	360	1
6	16	447	356	1
7	16	1434	100	1
8	16	379	288	1
9	16	1434	383	1
10	16	1434	400	1
11	3	1442	296	1

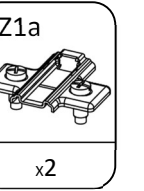
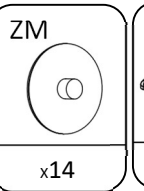
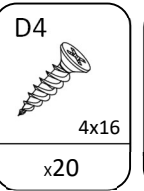
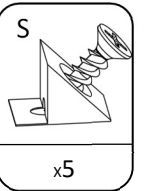
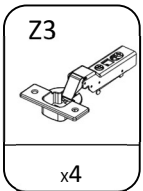
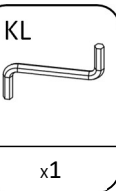
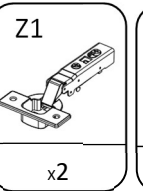
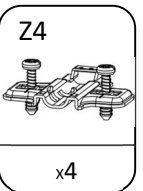
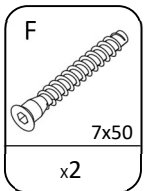
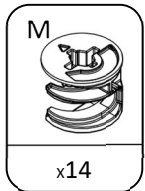
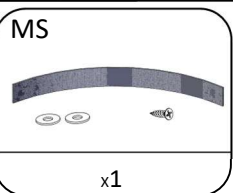
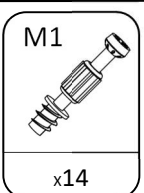
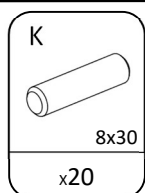

1

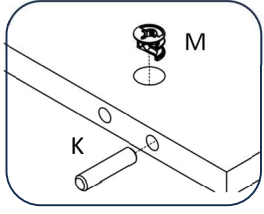
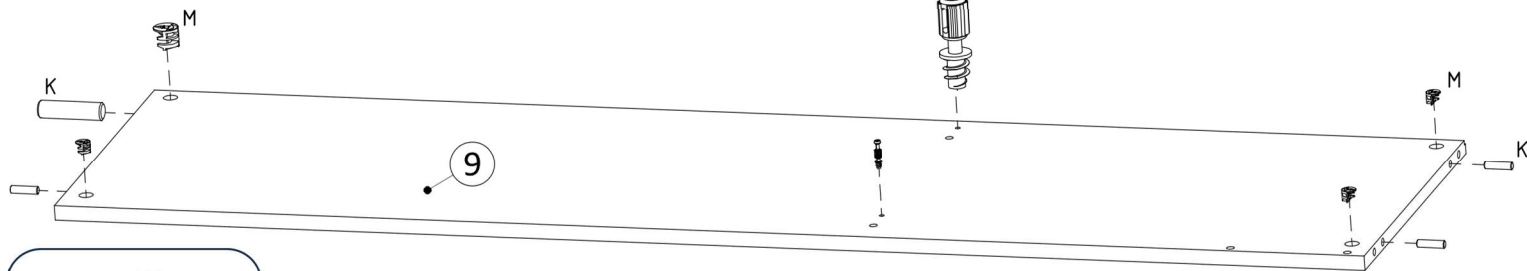
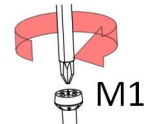
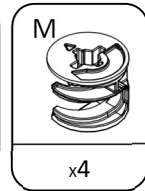
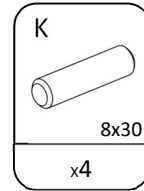
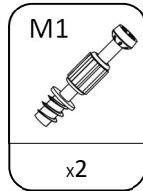
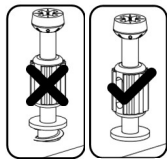

2

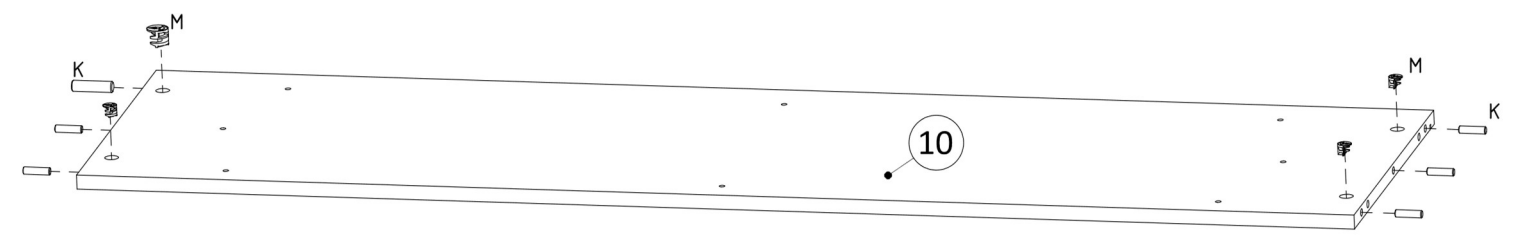
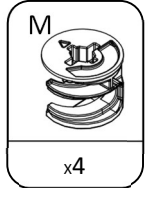
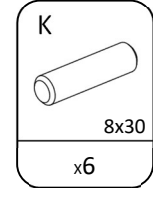
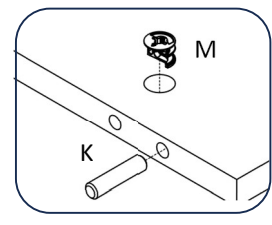

3

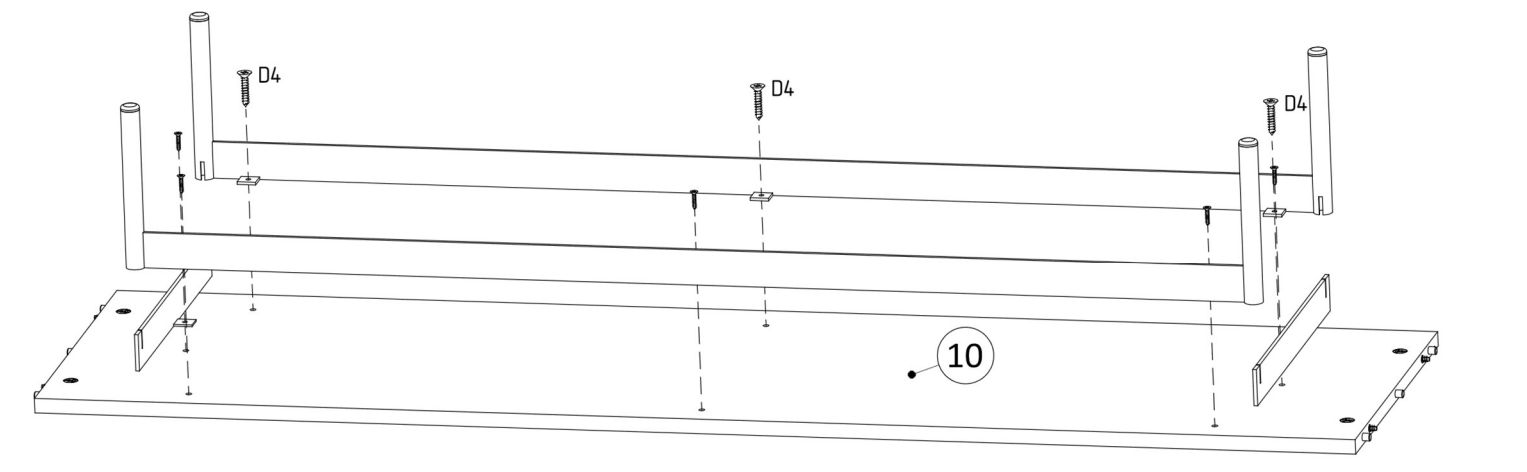
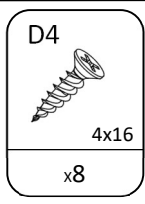

4

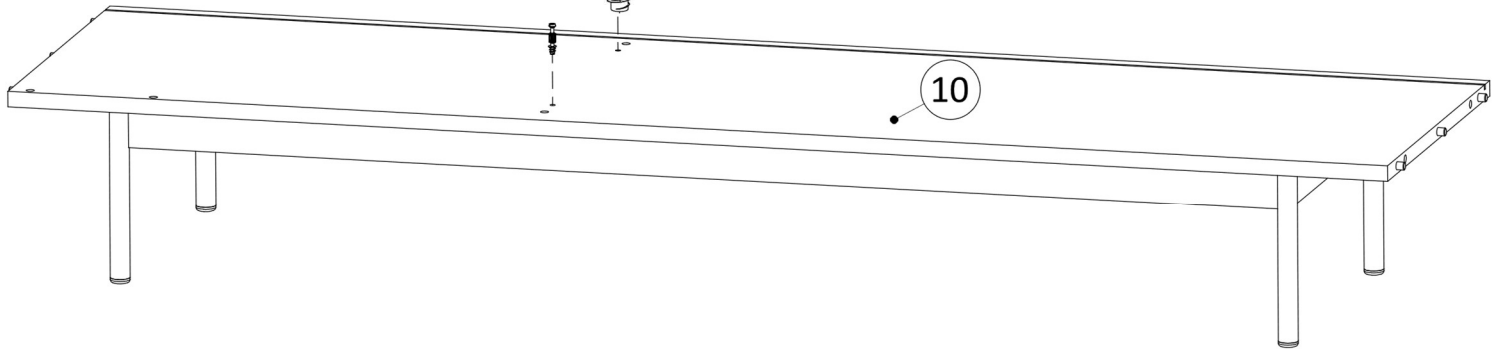
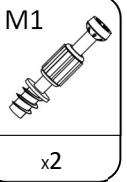
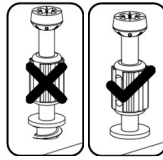
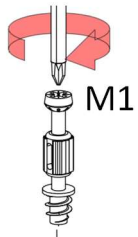

5

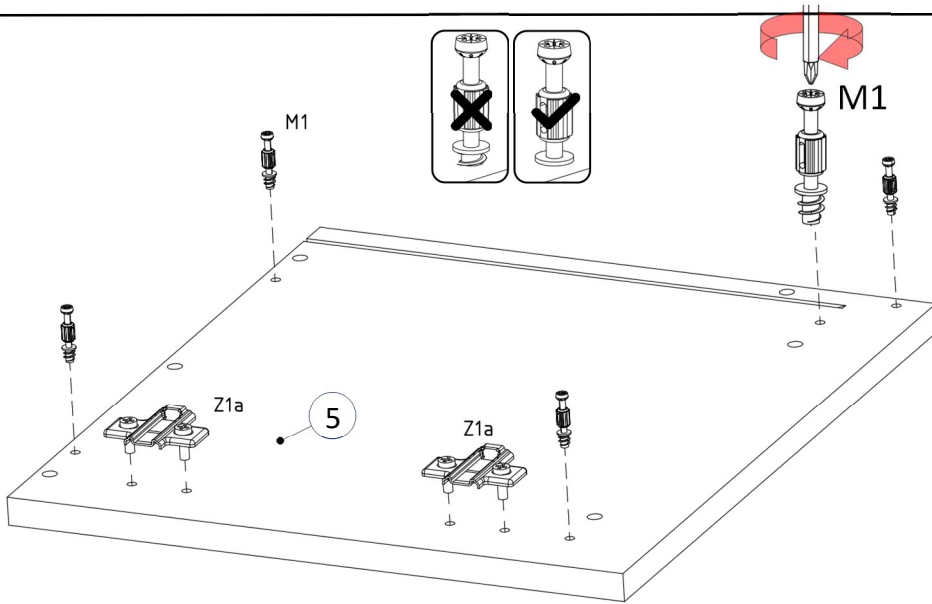
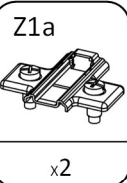
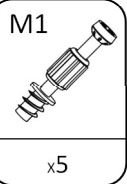
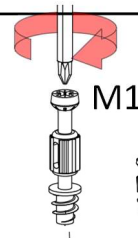
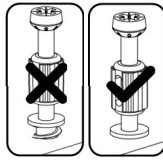

6

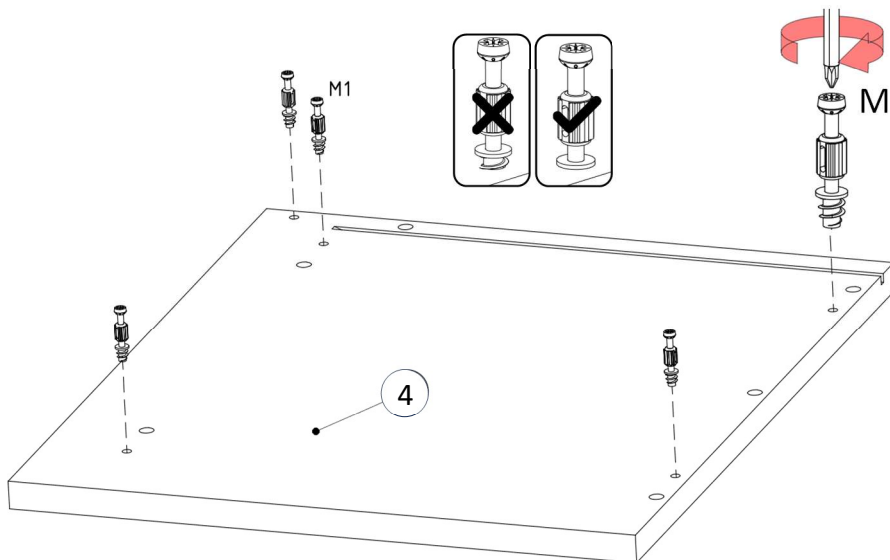
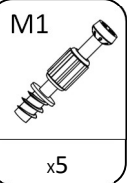
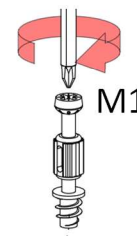
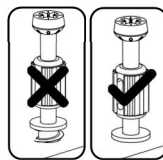

7

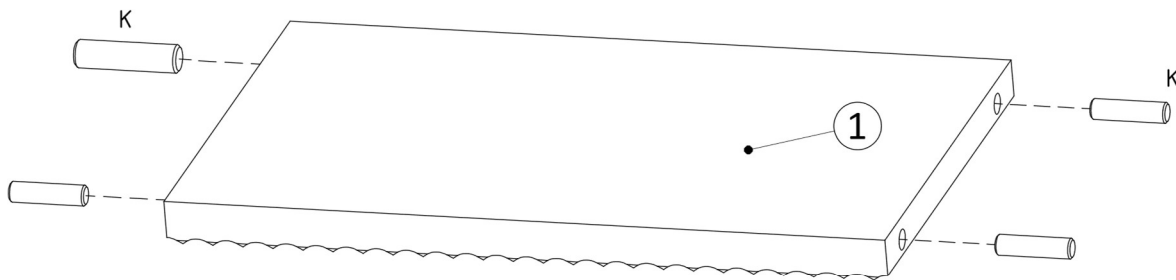

K

8x30
x4

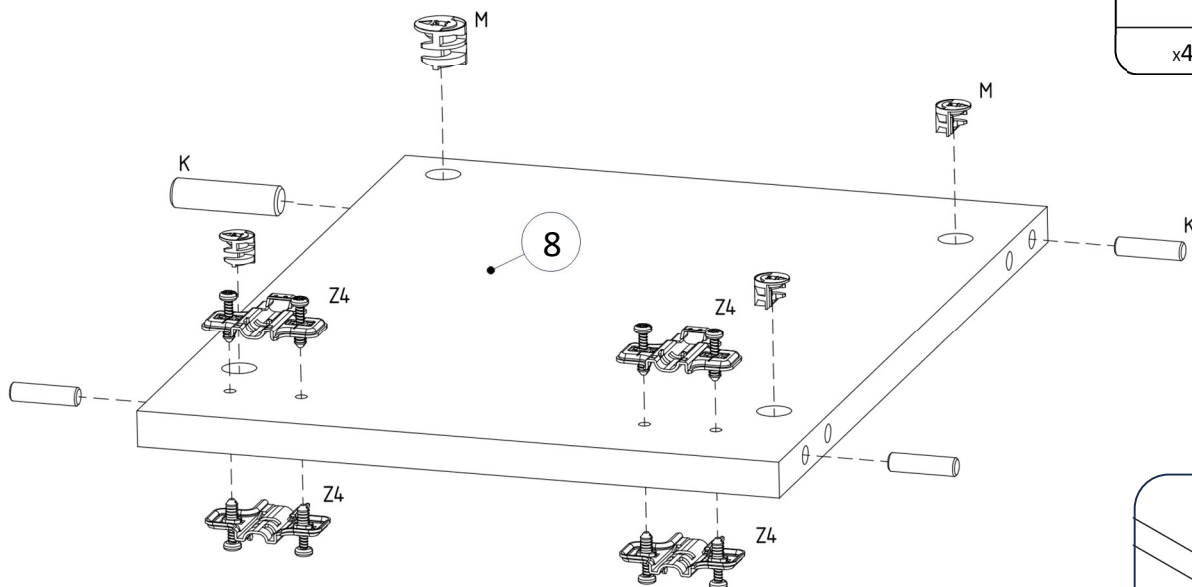
8

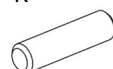

K

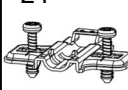
8x30
x4

M

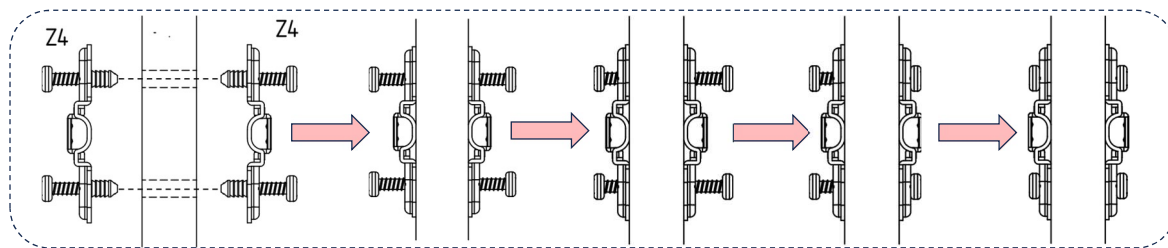
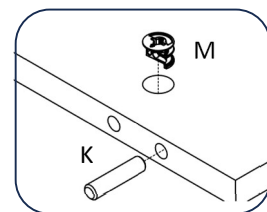
x4

Z4

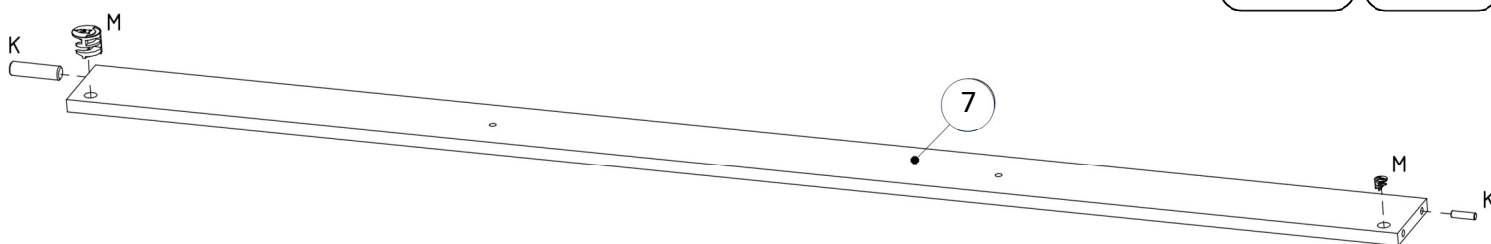
x4



9



M

x2

K

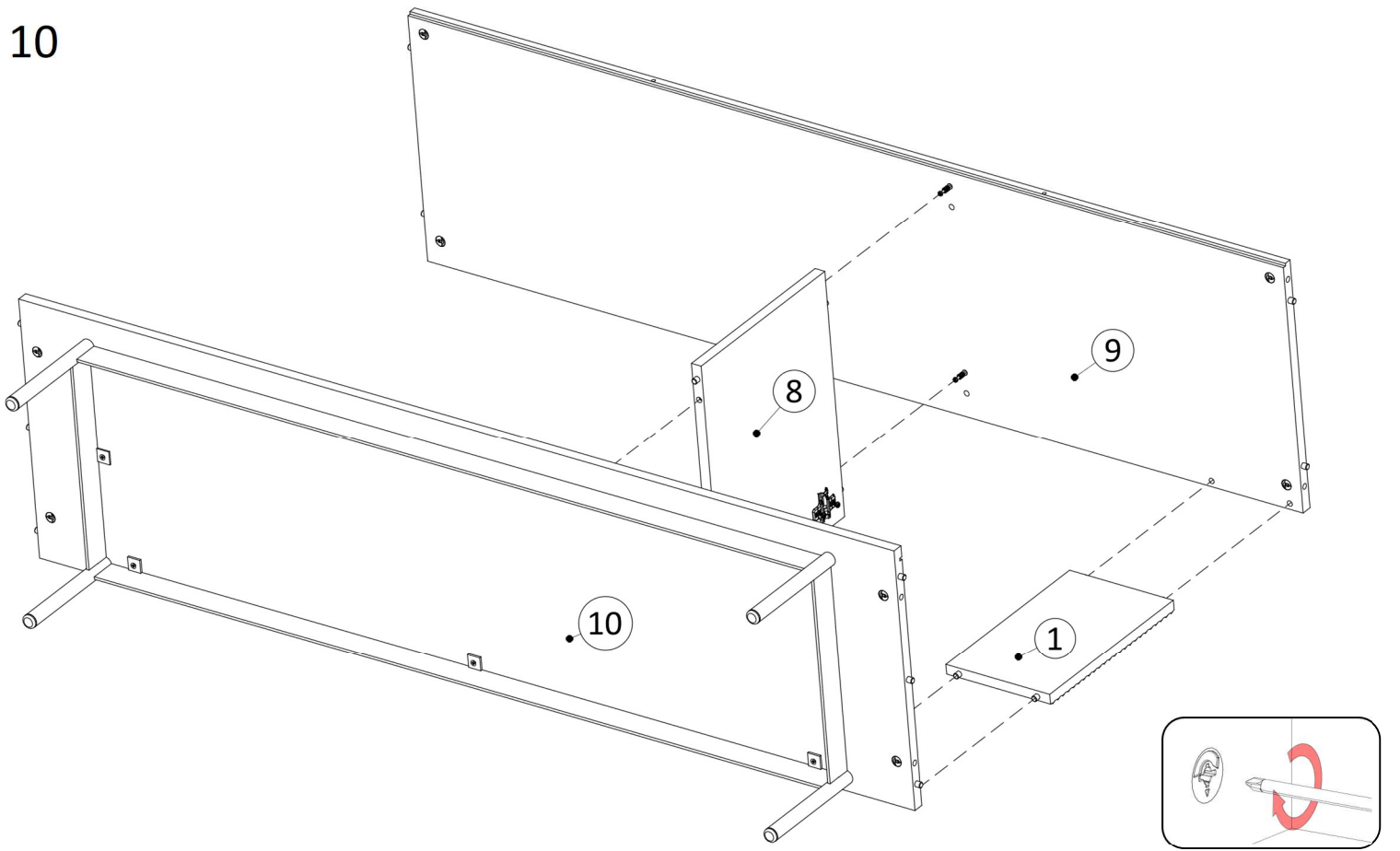
8x30
x2

10

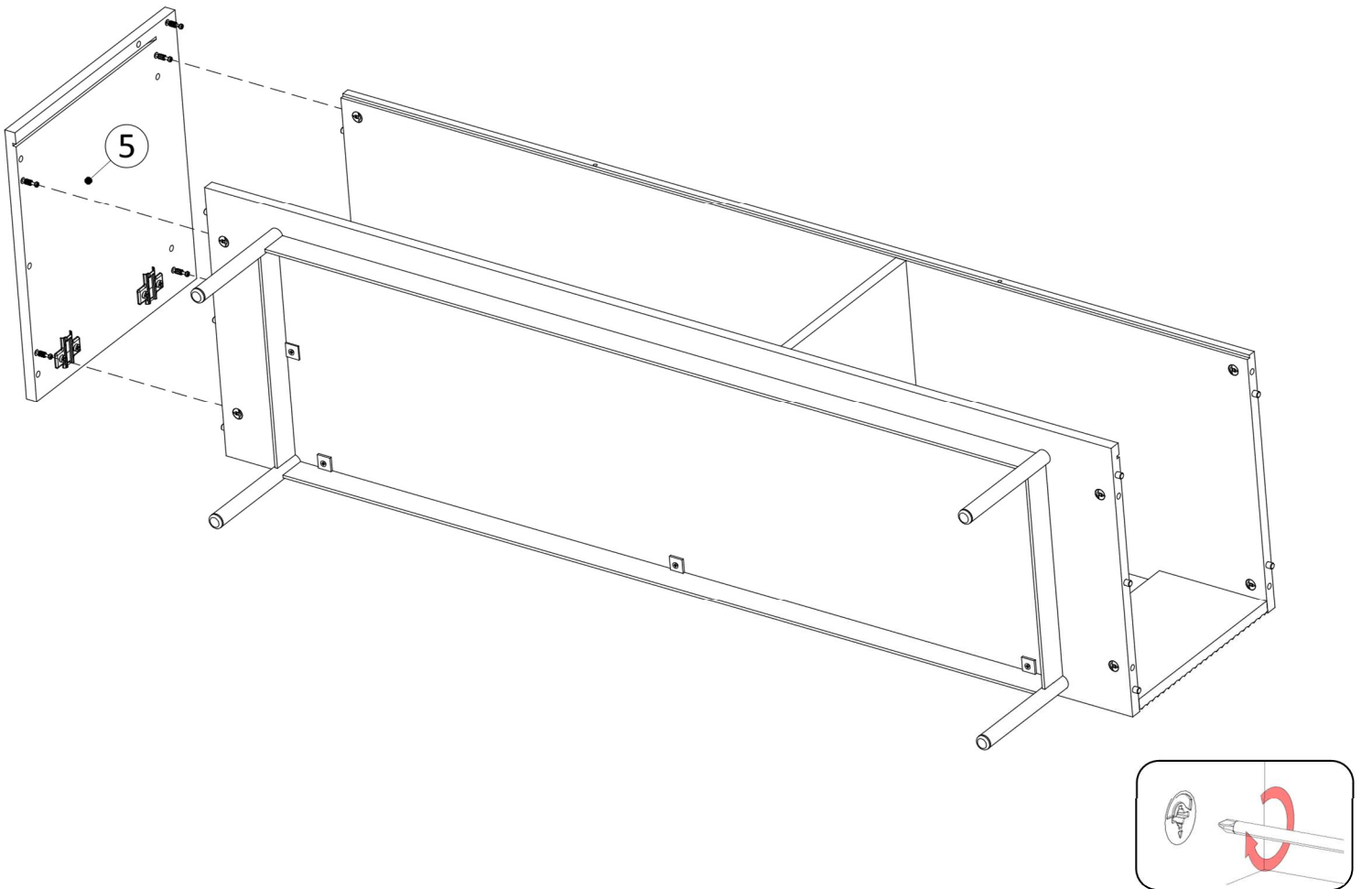

11



12

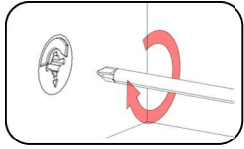
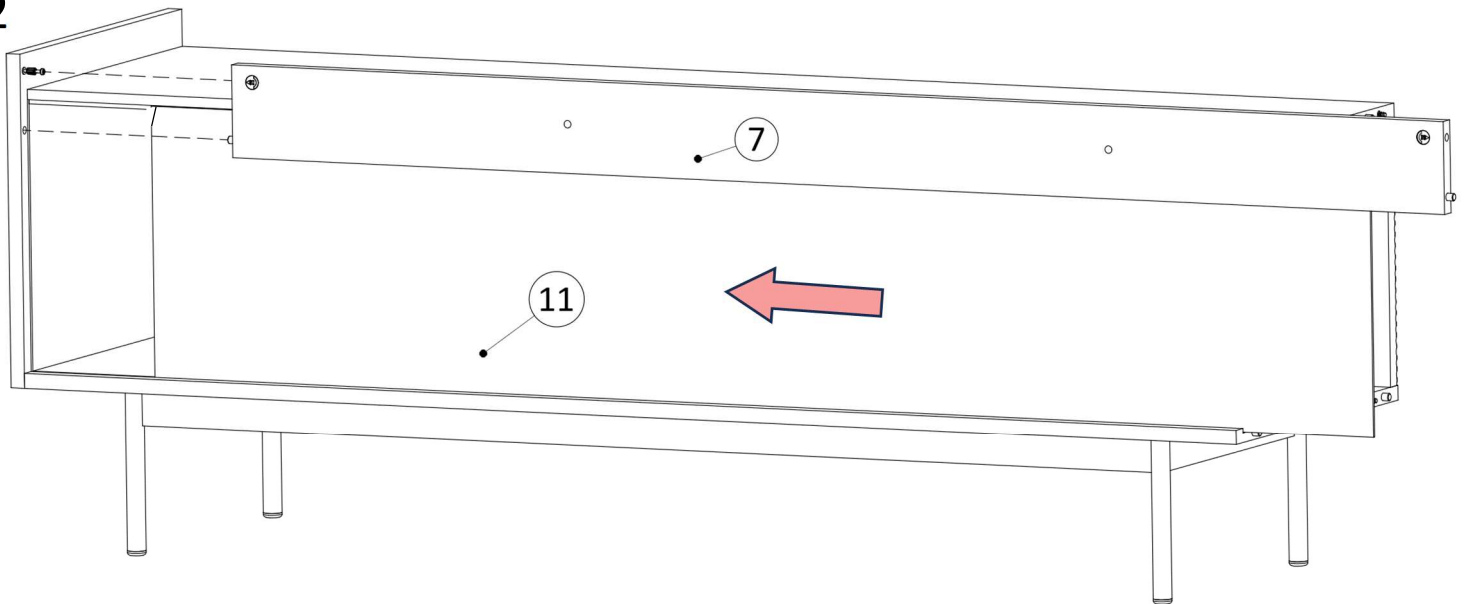

13

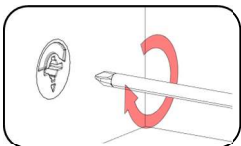
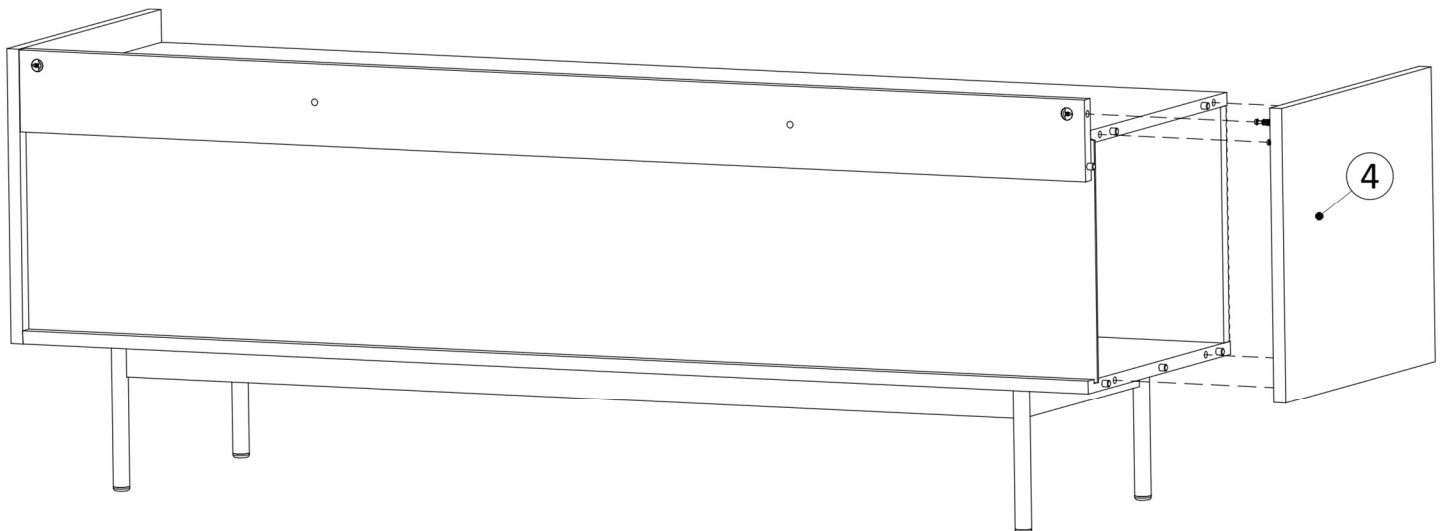

16

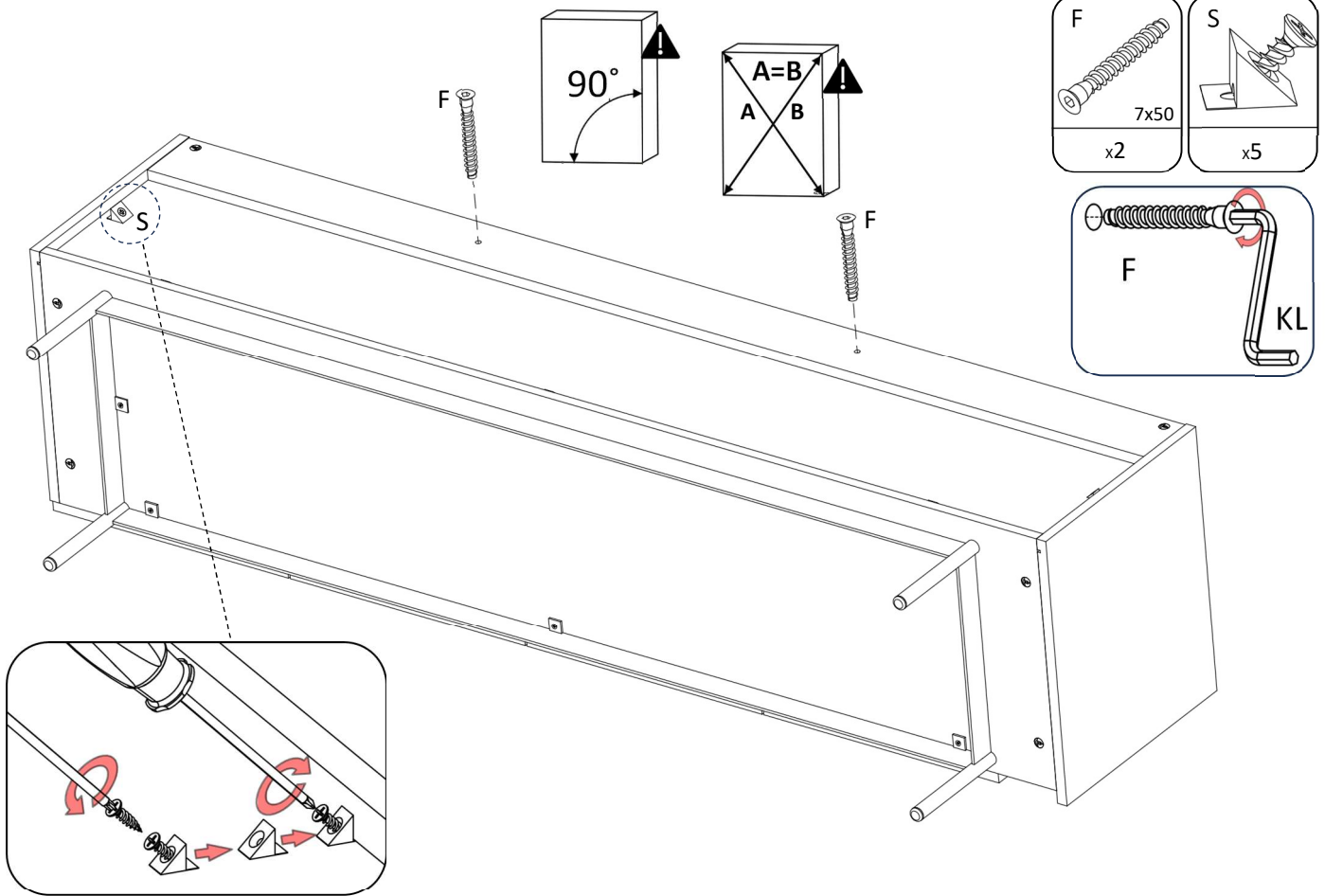

17

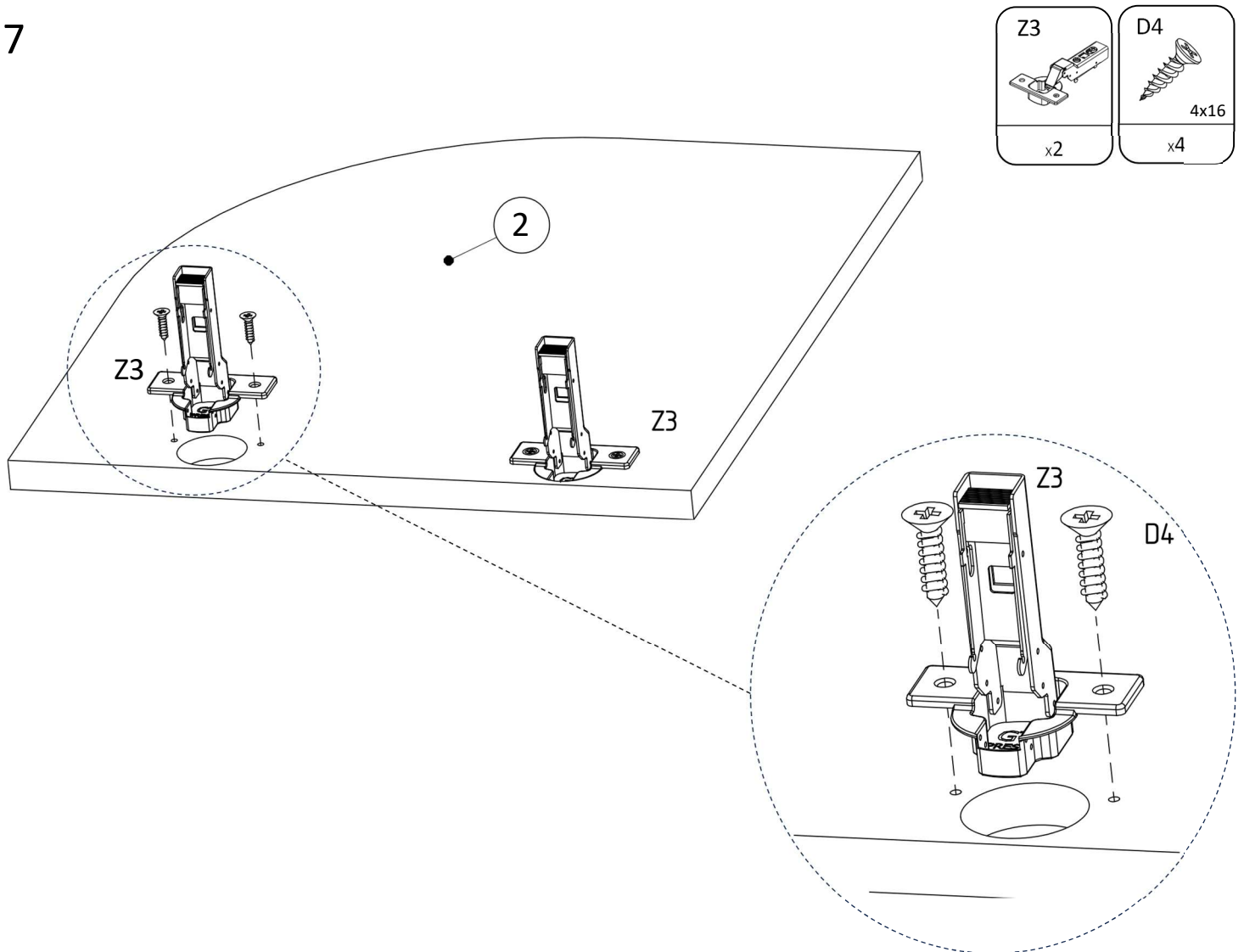

18

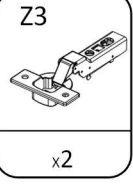
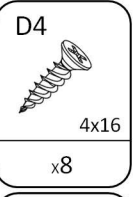
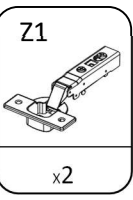
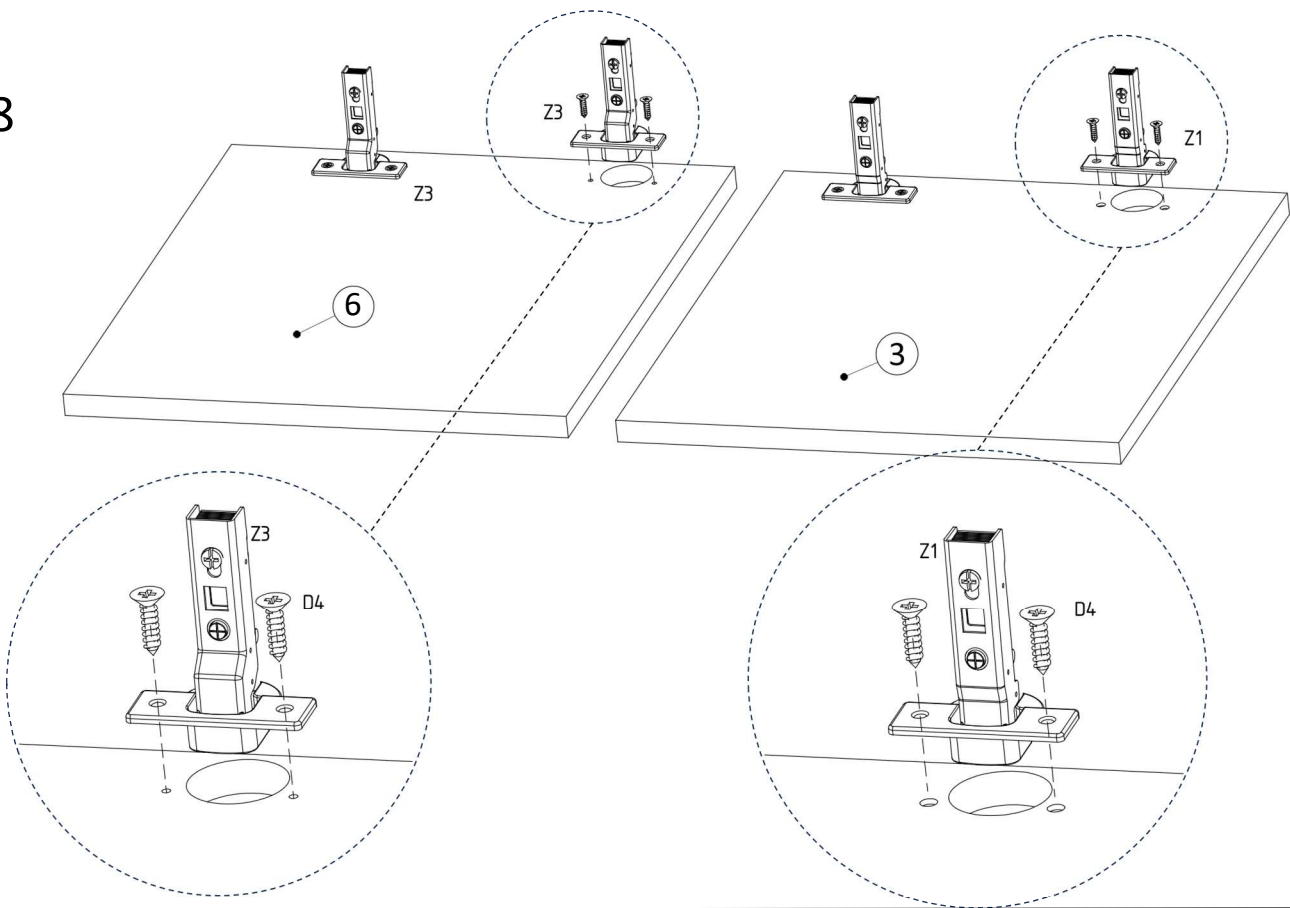

19

