

# KAROL

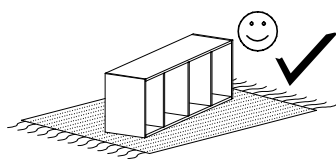

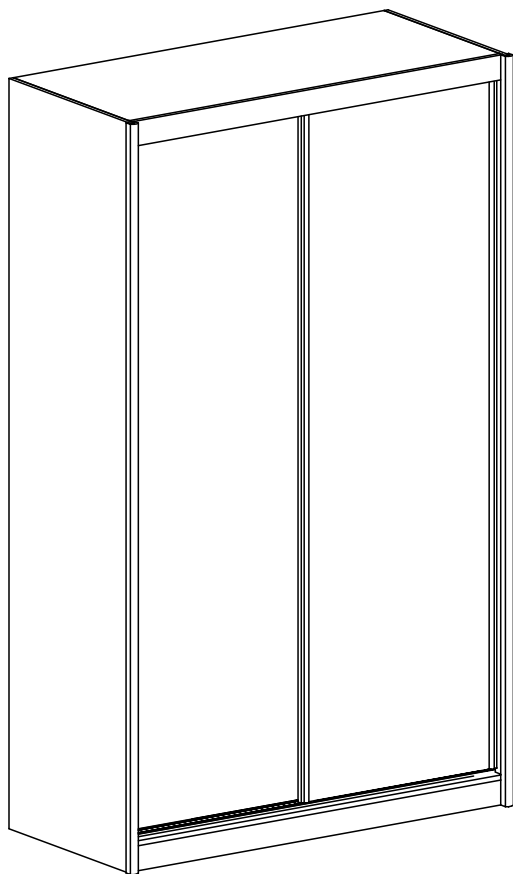











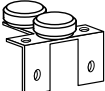
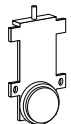
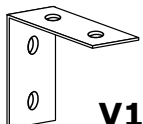
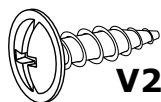

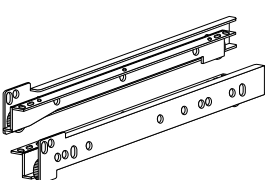

Narzędzia potrzebne do montażu

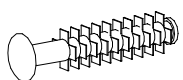
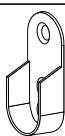

## UWAGA !!!

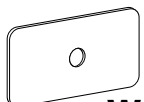
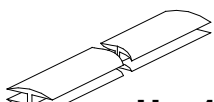
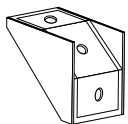
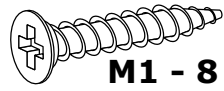
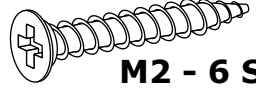
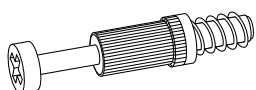
MONTOWANIE USZKODZONYCH  
ELEMENTÓW POWODUJE UTRATĘ  
GWARANCJI

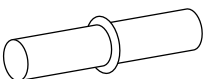
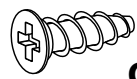
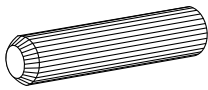
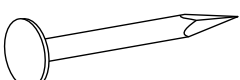
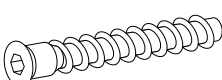
W przypadku reklamacji proszę podać numer pakowacza znajdujący się na kartonie.

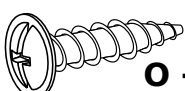
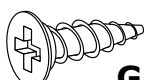
					 <b>X2 - 32 St.</b>	
					 <b>X1 - 8 St.</b>	 <b>SZ1 - 2,30m.</b>
 <b>D - 4 St.</b>	 <b>N - 4 St.</b>	 <b>V1 - 1 St.</b>	 <b>V2 - 2 St.</b> 3,5x16 mm	 <b>SZ2 - 4,6m.</b>		
 <b>U - 2 St.</b>	 <b>Z1 - 1 St.</b>	 <b>T - 2 Kpl.</b>		 <b>I1 - 1 St.</b>	 <b>I2 - 1 St.</b>	
 <b>Y - 2 St.</b>	 <b>F - 8 St.</b>	 <b>S - 2 St.</b>		 <b>J - 1 St.</b>		
 <b>W - 10 St.</b>	 <b>H - 1 St.</b>	 <b>C - 4 St.</b>	 <b>M1 - 8 St.</b> 3,9x25 mm	 <b>M2 - 6 St.</b> 3,9x30 mm		
 <b>K - 8 St.</b>	 <b>L - 8 St.</b>	 <b>P - 16 St.</b>	 <b>Q - 8 St.</b> 5x13 mm	 <b>B - 39 St.</b>		
 <b>E - 100 St.</b>	 <b>A - 32 St.</b>	 <b>R - 10 St.</b>	 <b>O - 4 St.</b> 4x27 mm	 <b>G - 22 St.</b> 3,5x16 mm		

I

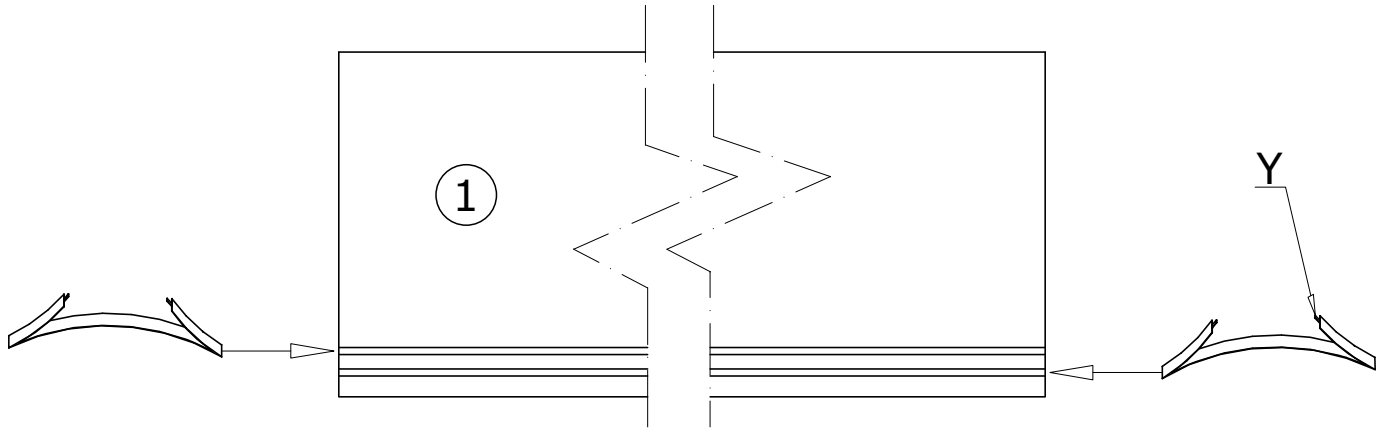
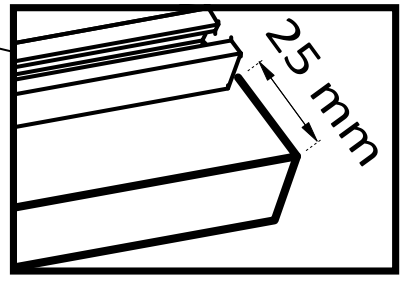
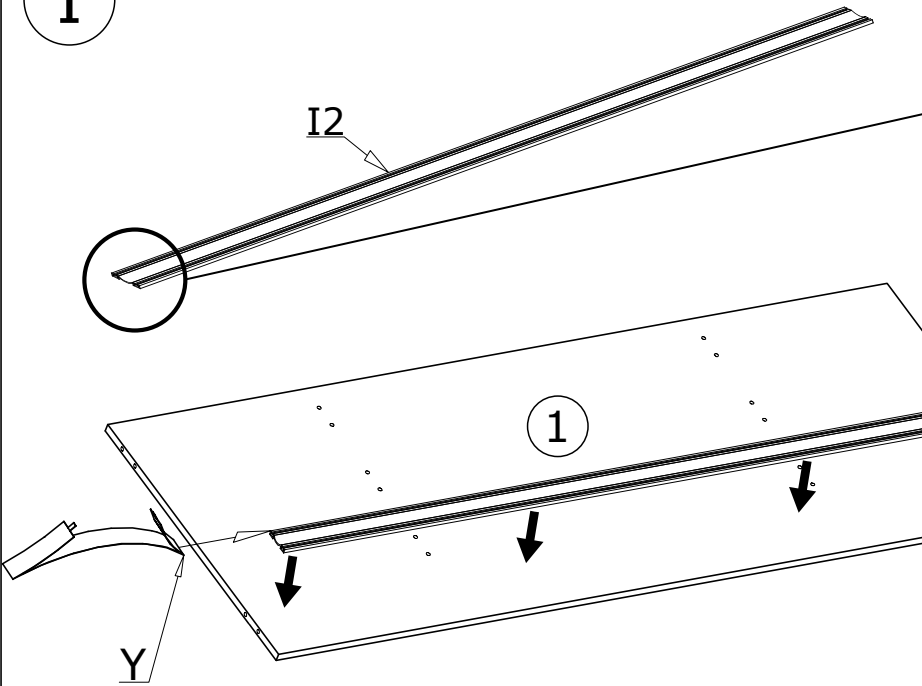
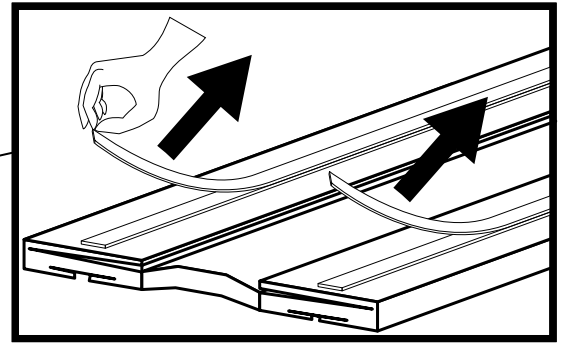

II

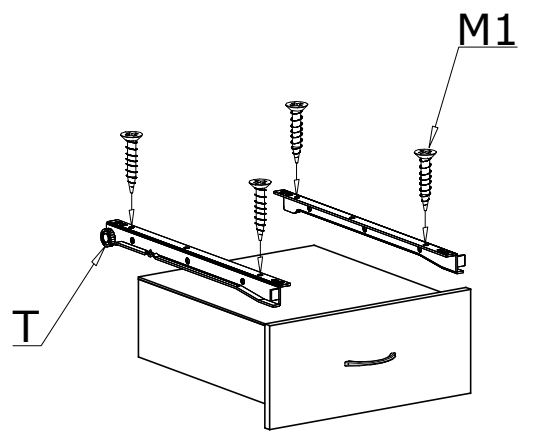
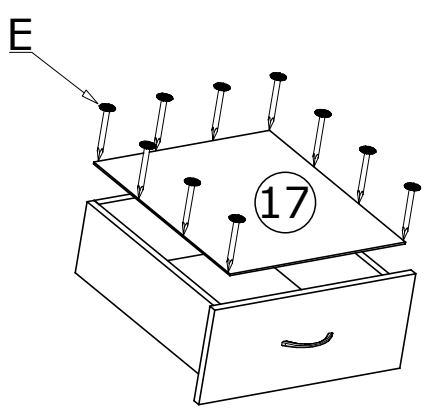
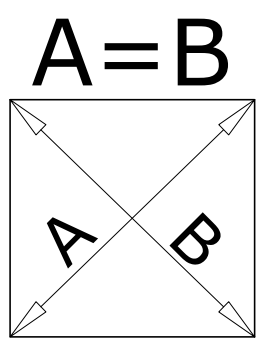
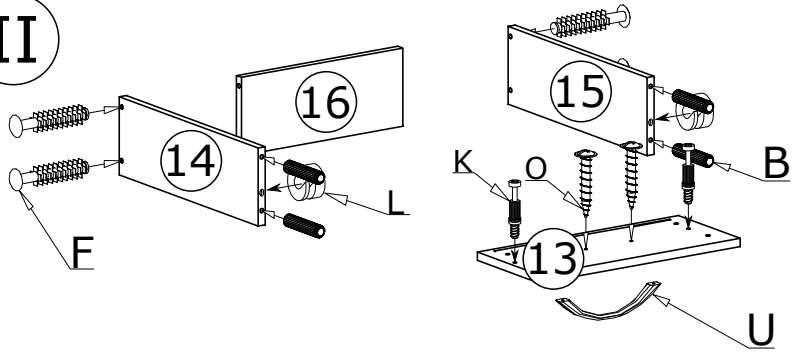
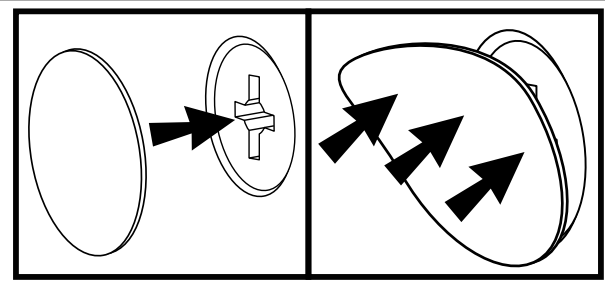

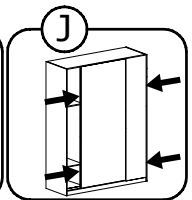
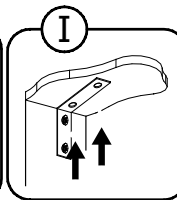
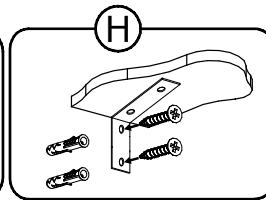
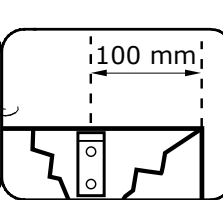
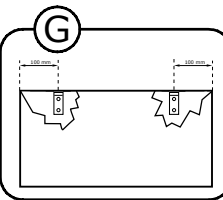
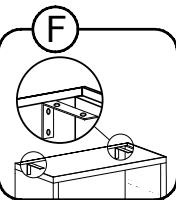
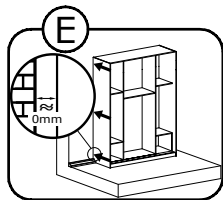
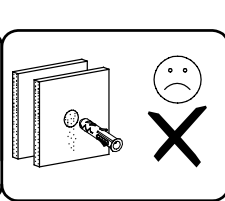
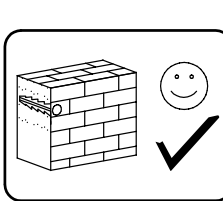
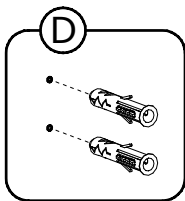
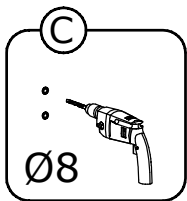
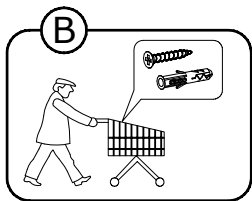
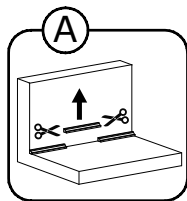
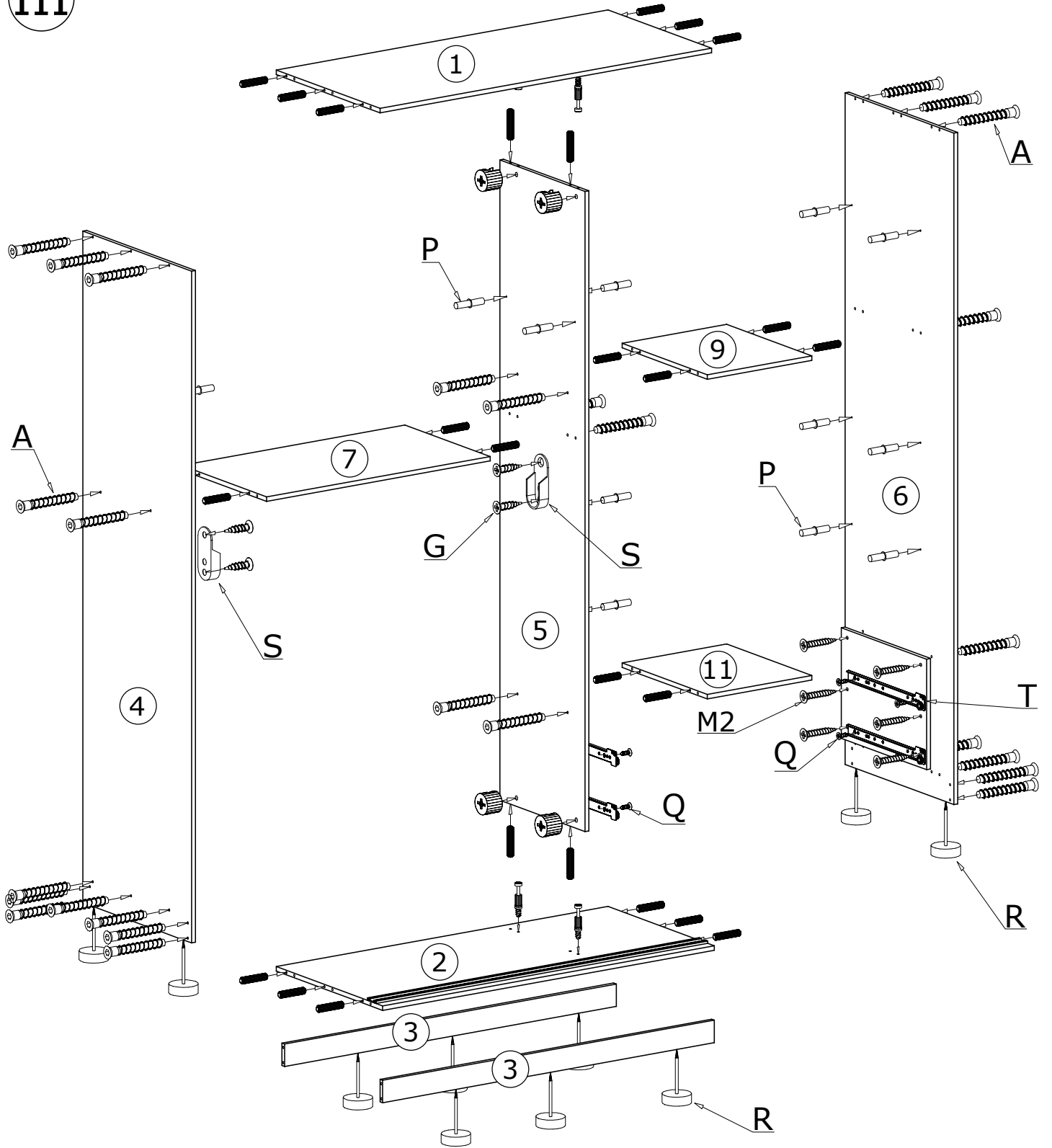

IV

100X 

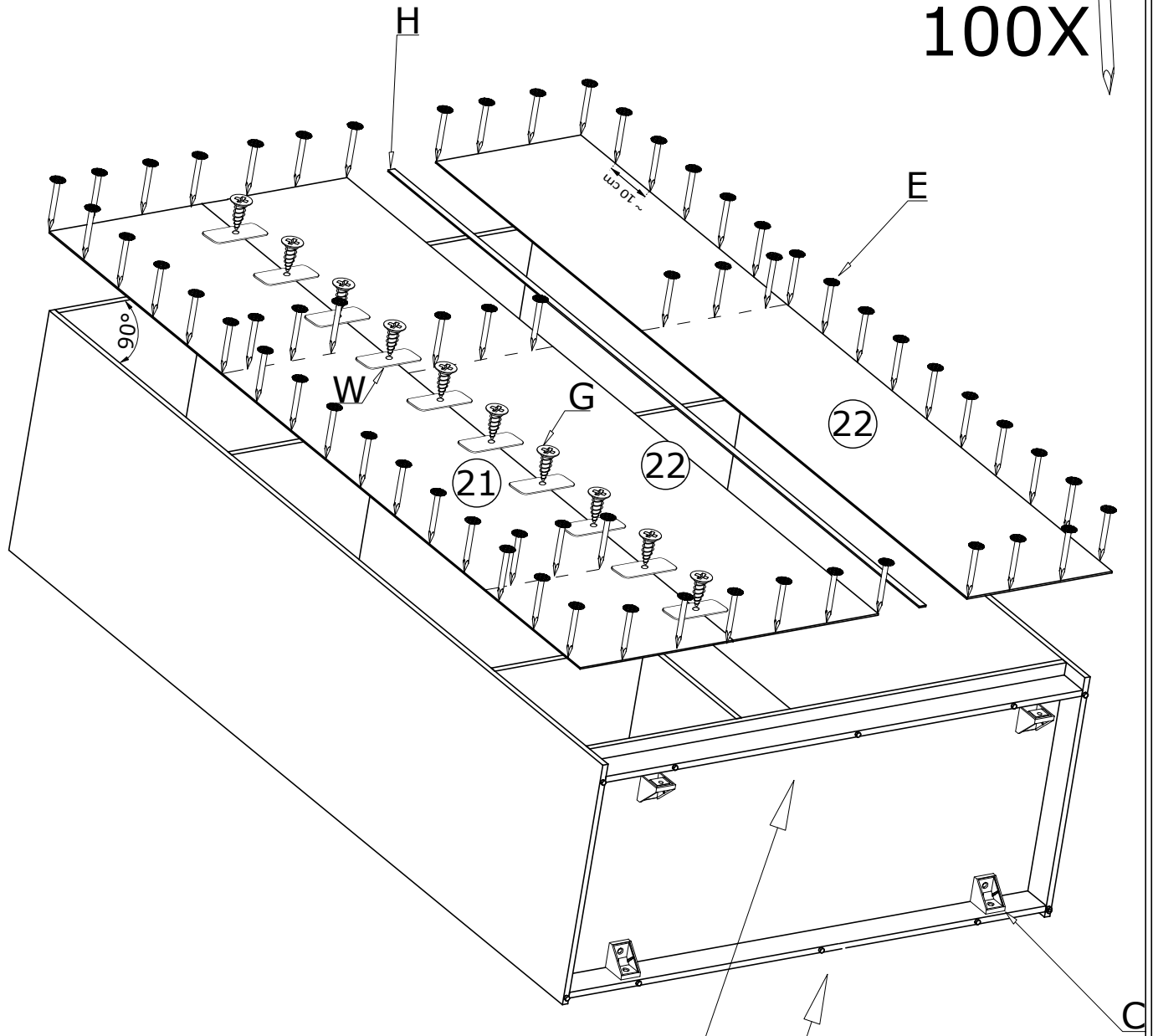

$A = B$

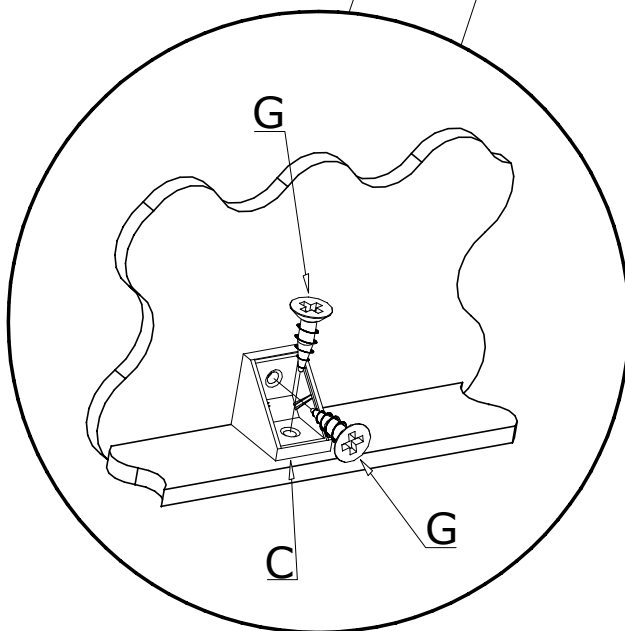
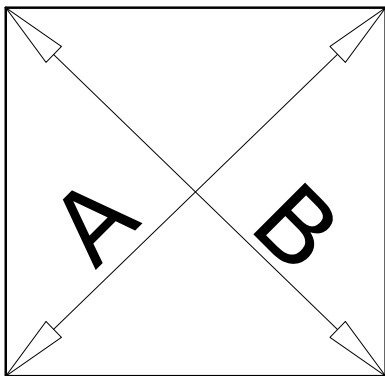

V

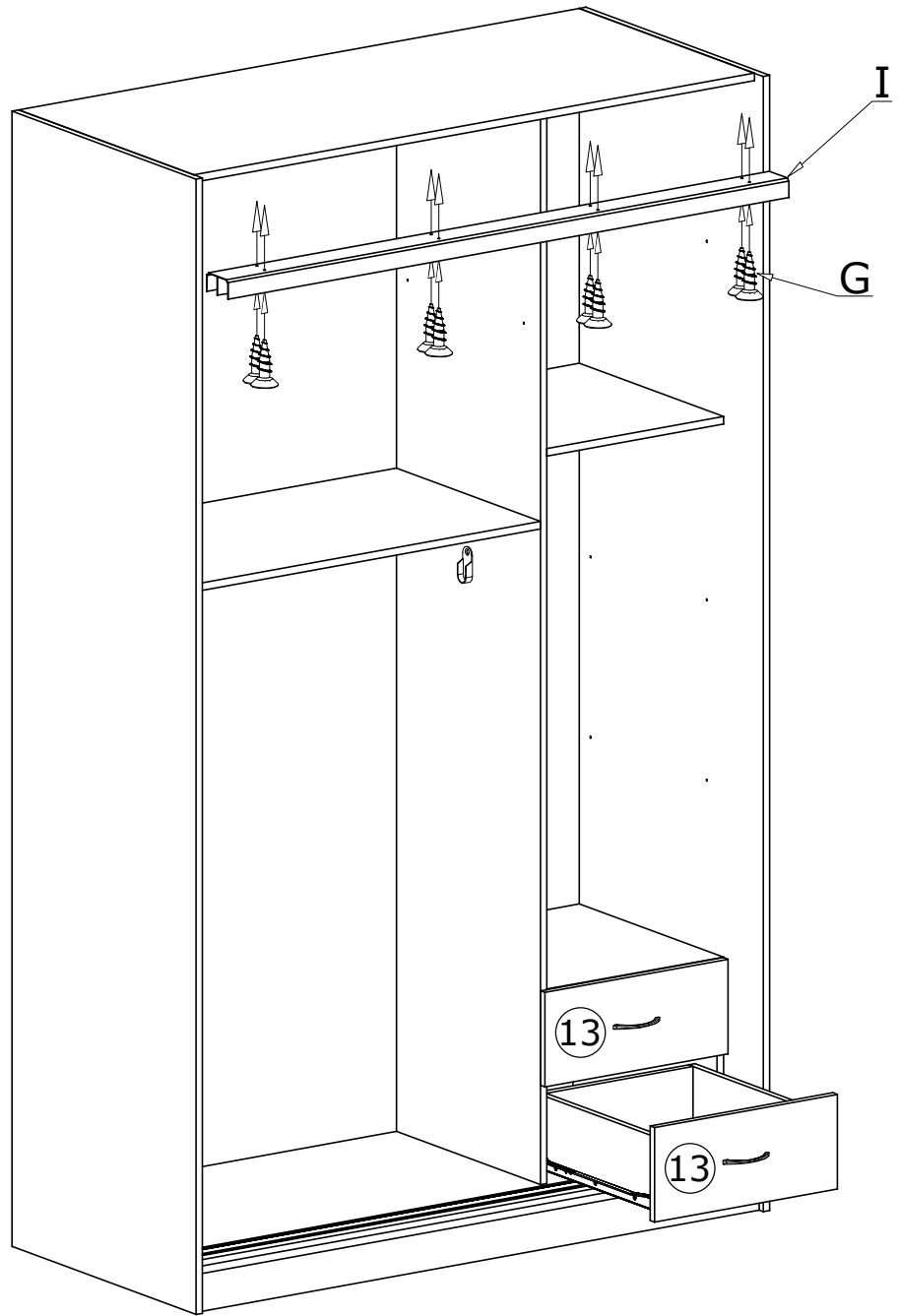

VI

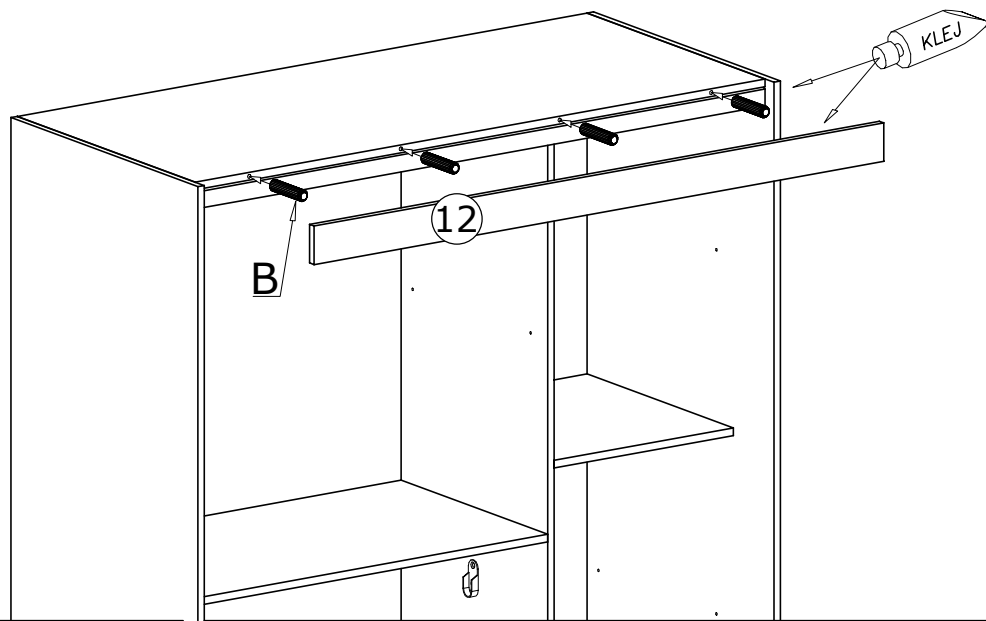

VII

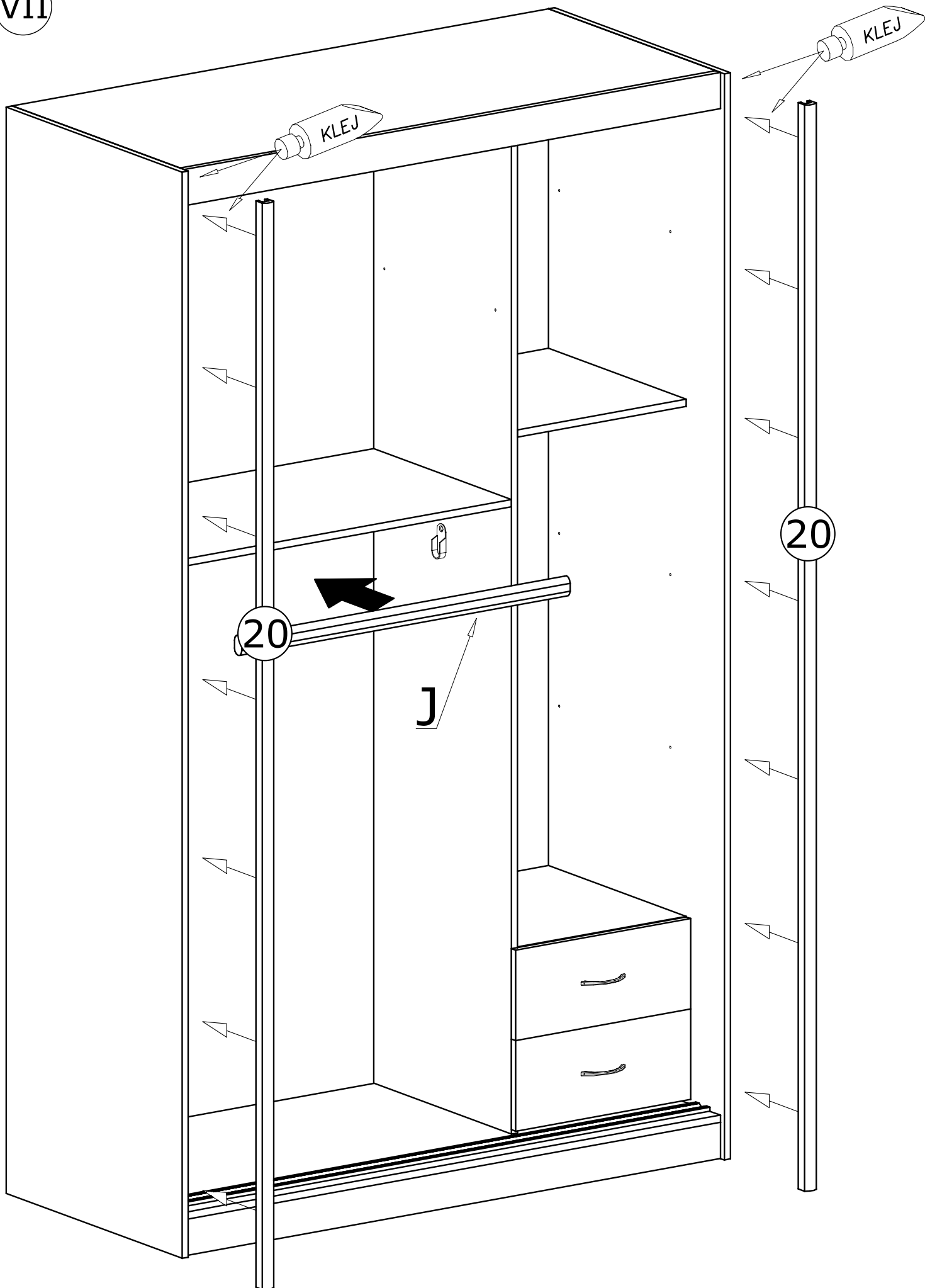

VIII

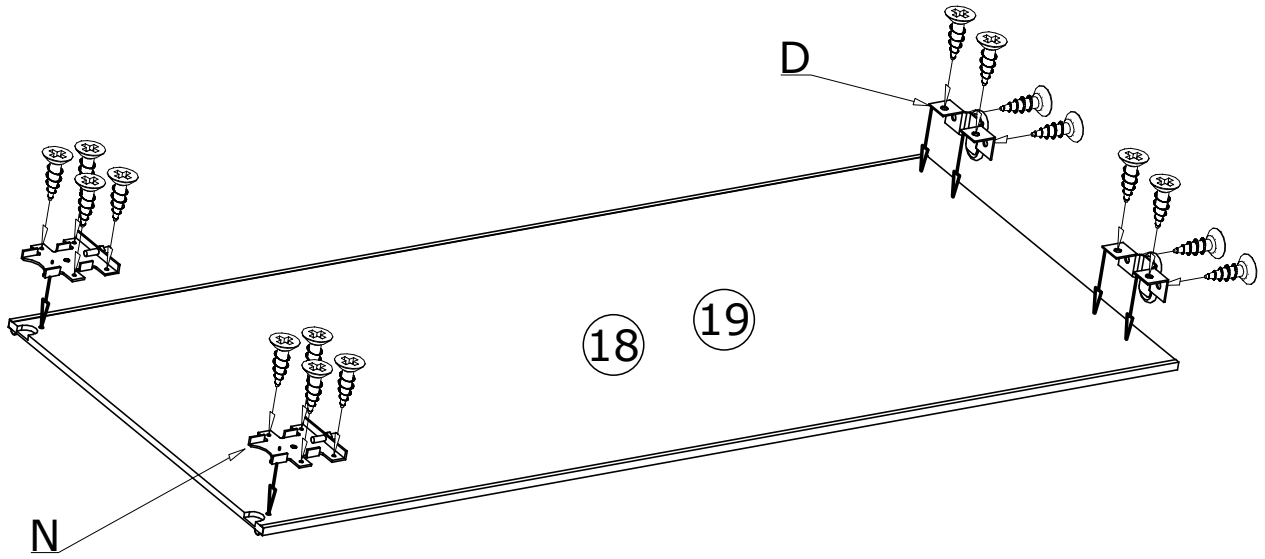

IX

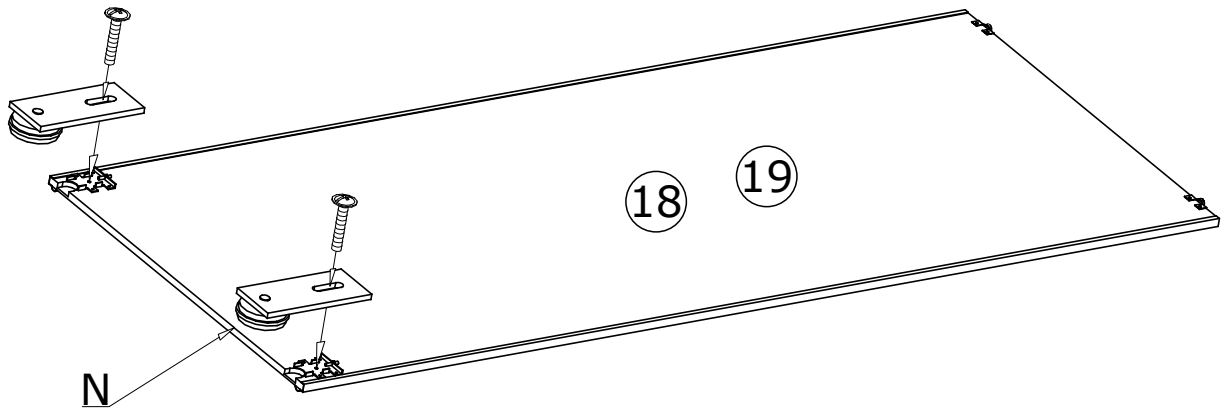

X

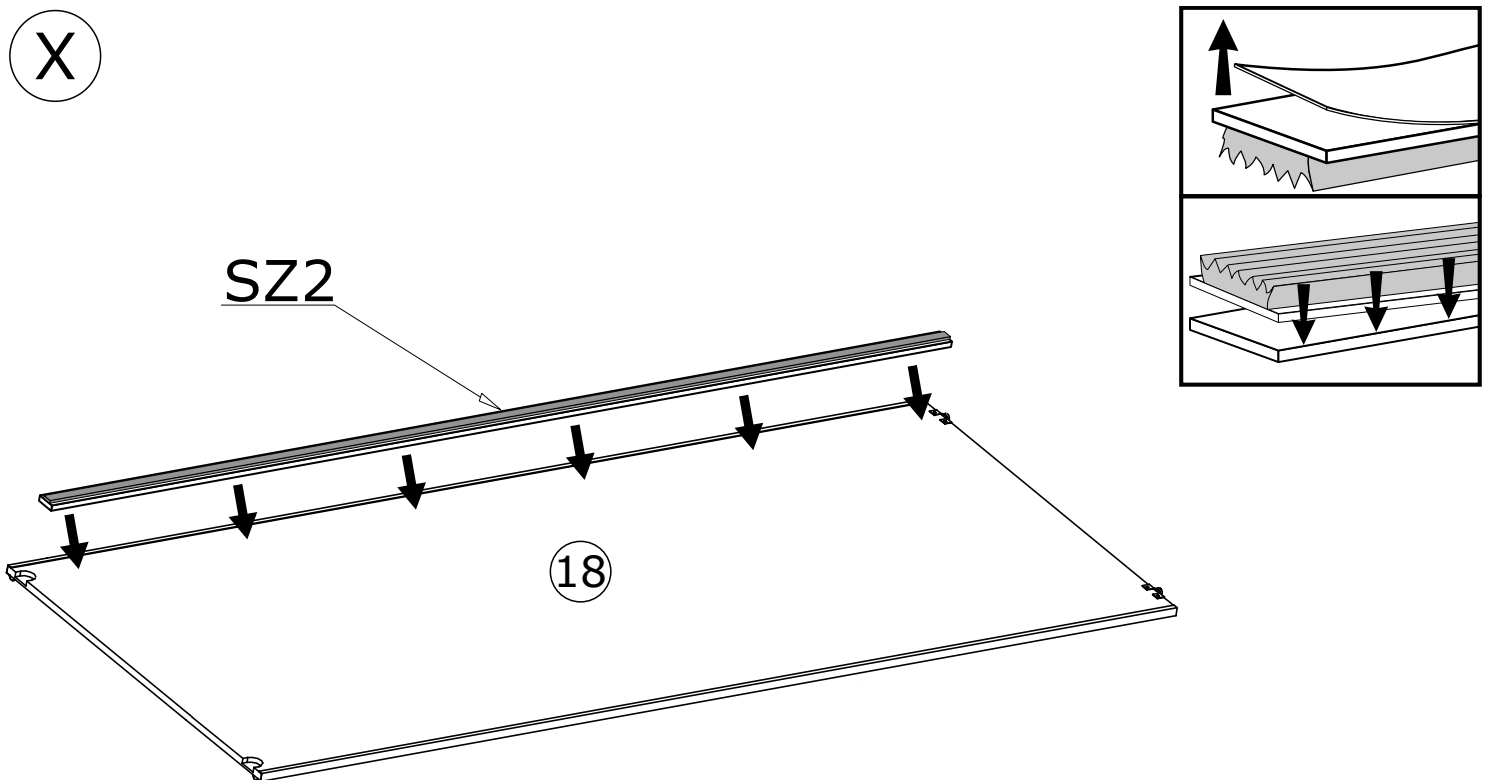

XI

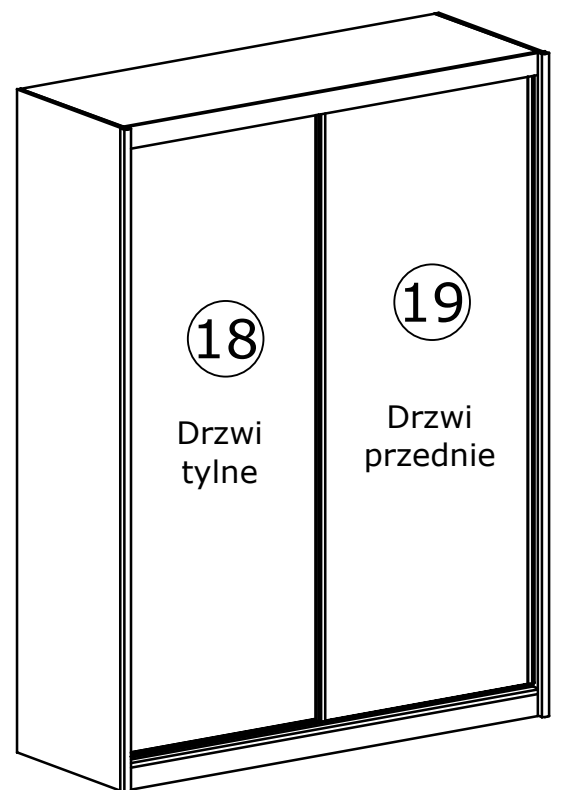
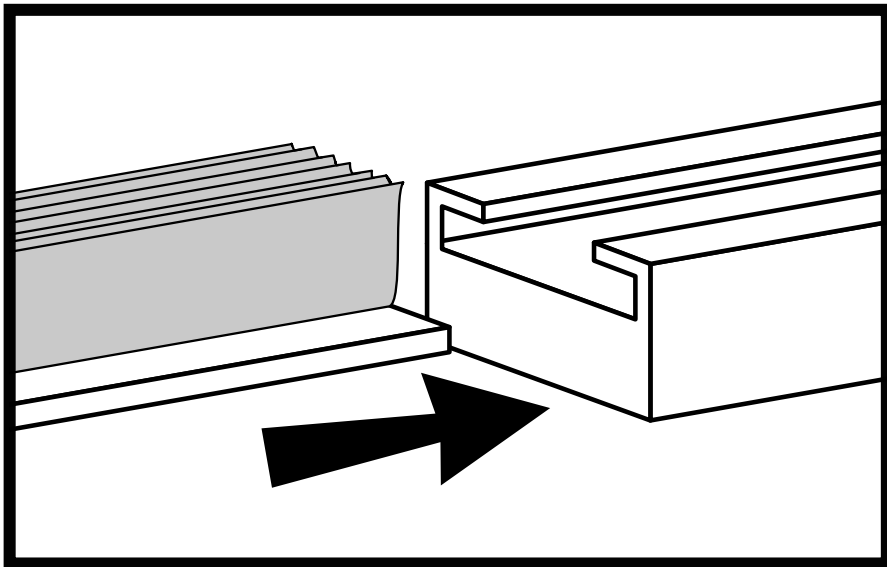
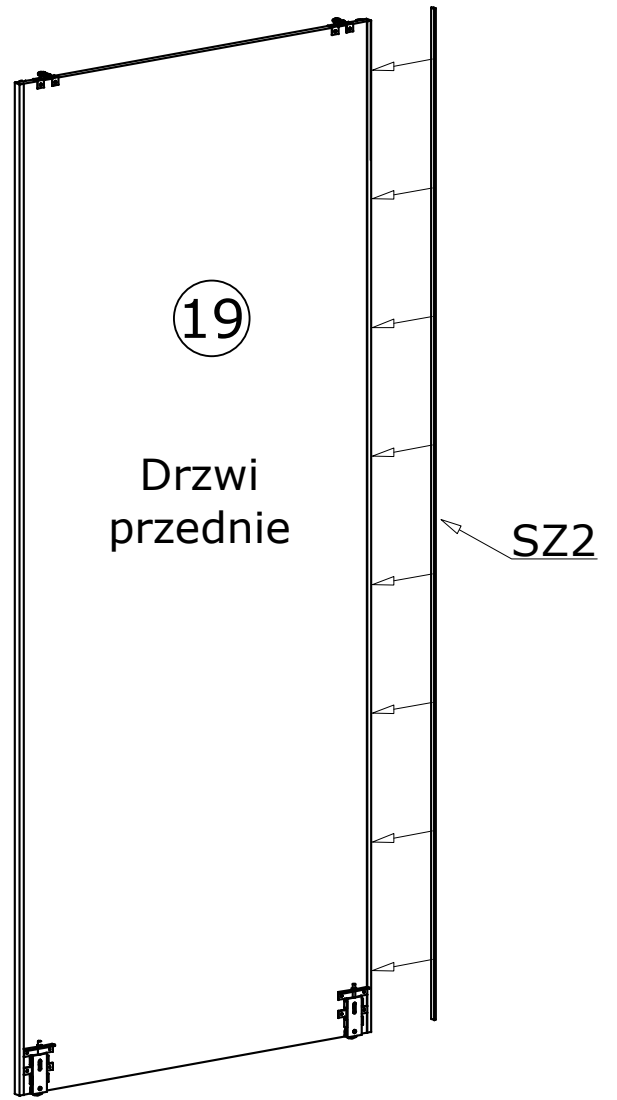
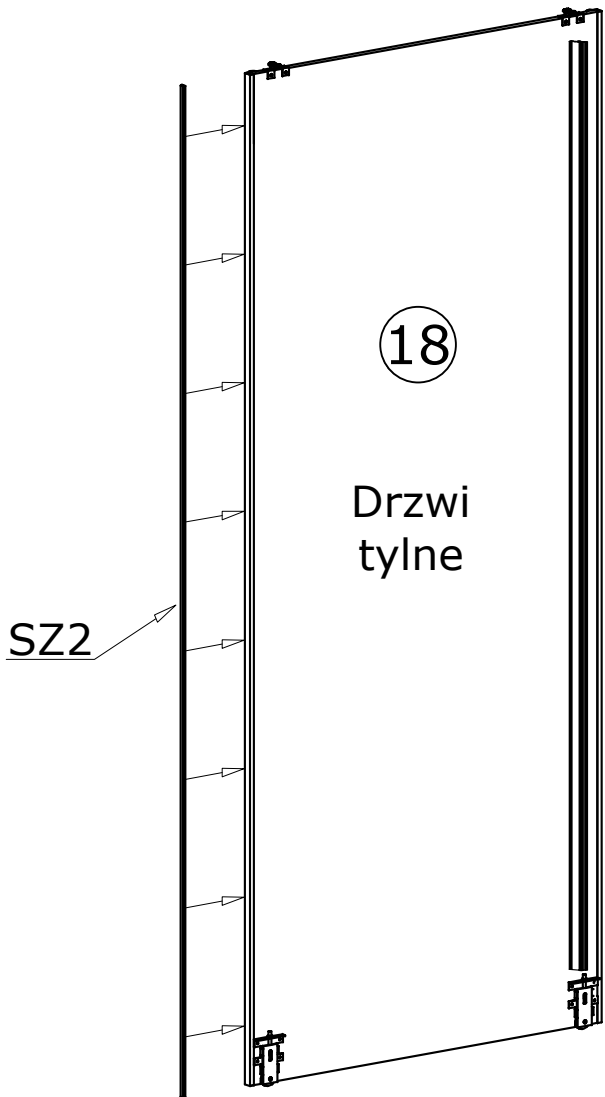



XII

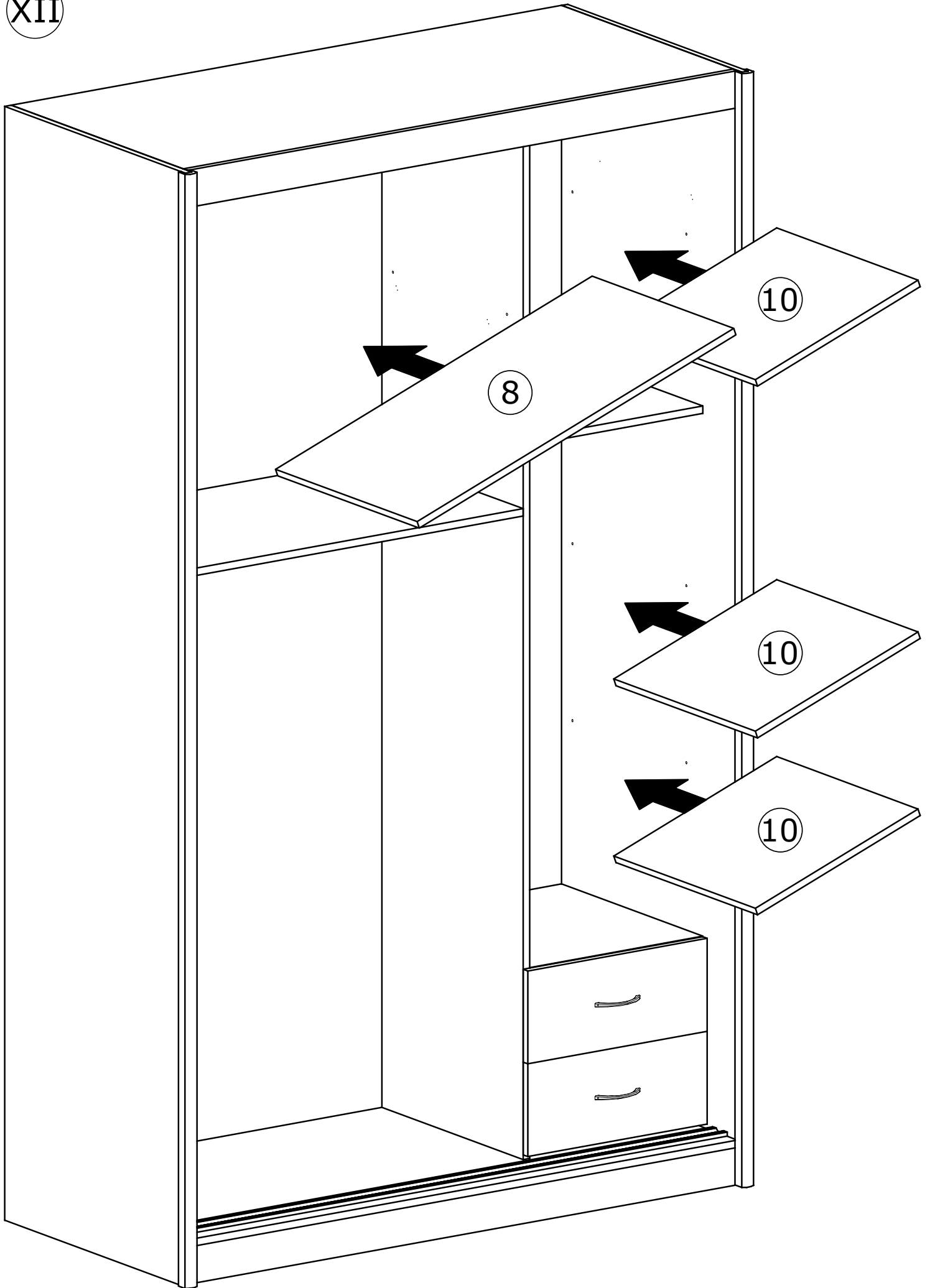

XIII

1

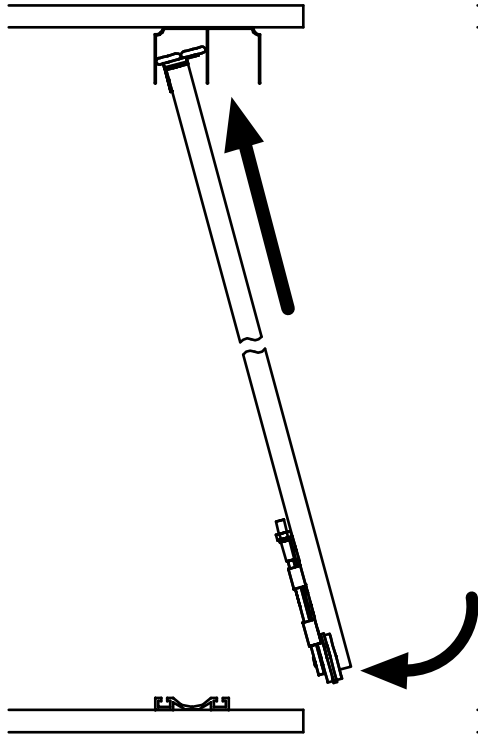

2

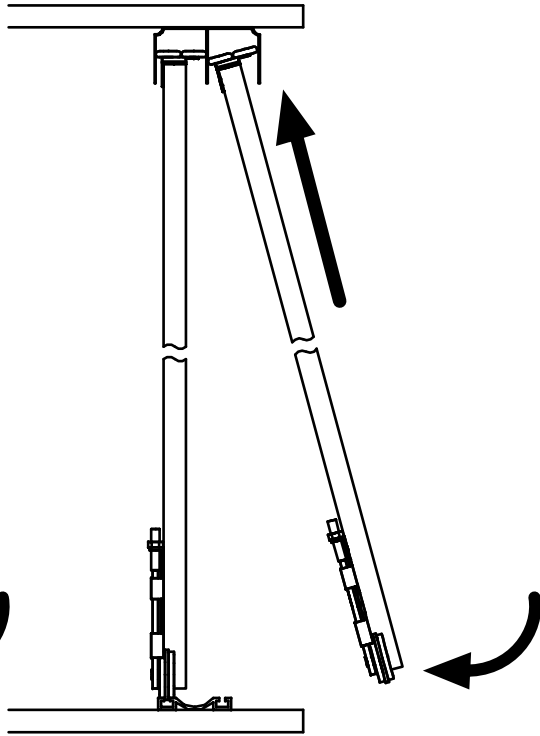

3

