

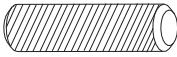









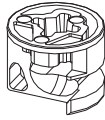
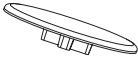
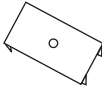

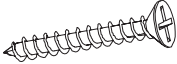
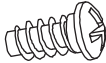
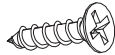
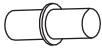
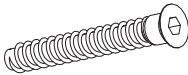
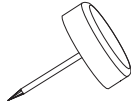

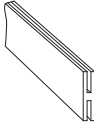

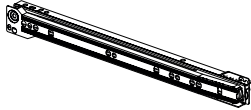

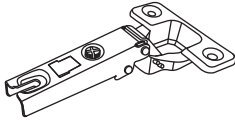
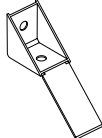
<b>K1</b> x 30 	<b>GW1</b> x 50 	<b>B2</b> x 19 
<b>ZM1</b> x 14 	<b>BR1</b> x 6 	<b>ZJ1</b> x 19 
<b>WT22</b> x 6 4x35 	<b>WE2</b> x 4 6,3x13B 	<b>WT1</b> x 24 3,5x15 
<b>PO2</b> x 8 	<b>KT1</b> x 10 6,3x50 	<b>SG1</b> x 6 
<b>x 1</b> 	<b>LT</b> x 1 	<b>KL</b> x 1 
<b>WS1</b> x 2 	<b>P5</b> x 2 	<b>UIQ</b> x 3 
<b>PK4</b> x 2 H-4 	<b>ZP9</b> x 2 	<b>PO4</b> x 2 
<b>SP</b> x 2 	<b>WT35</b> x 12 3x20 	<b>WT9</b> x 10 3x16 

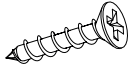
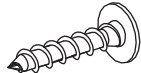
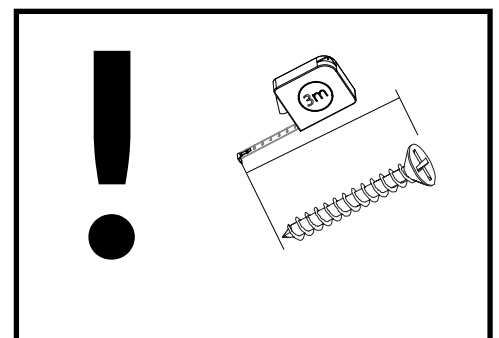

	CODE			
1	IQ09K_13	220	350	2
2	IQ09KHDF_01	851	355	2
3	IQ09K_10	835	458	1
4	IQ09W_02	875,50	353	1
5	IQ09KHDF_02	1373	324	1
6	IQ09KHDF_03	1373	272	2
7	IQ09K_08	398	349	2
8	IQ09K_05	841	382	1
9	IQ09K_14	825	220	1
10	IQ09K_03	917	401	1

	CODE			
11	IQ09K_04	917	401	1
12	IQ09W_01	1343	60	1
13	IQ09K_09	1343	60	1
14	IQ09K_07	524	300	1
15	IQ09K_06	928	381	1
16	IQ09K_02	1343	400	1
17	IQ09K_01	1378	402	1
18	IQ09K_11	124	350	2
19	IQ09K_12	825	124	1
20	IQ09W_03	876	238	1

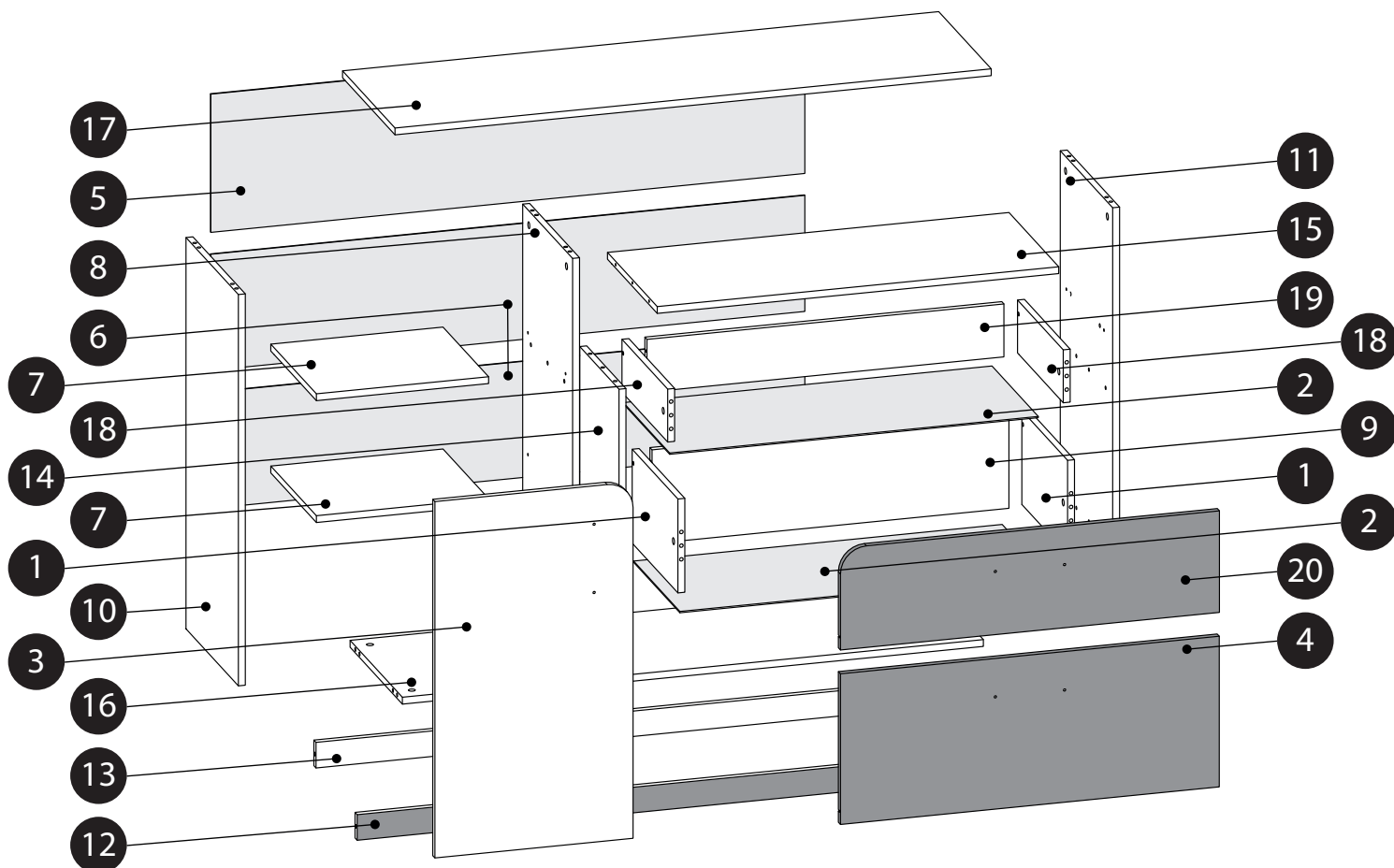
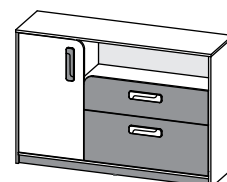

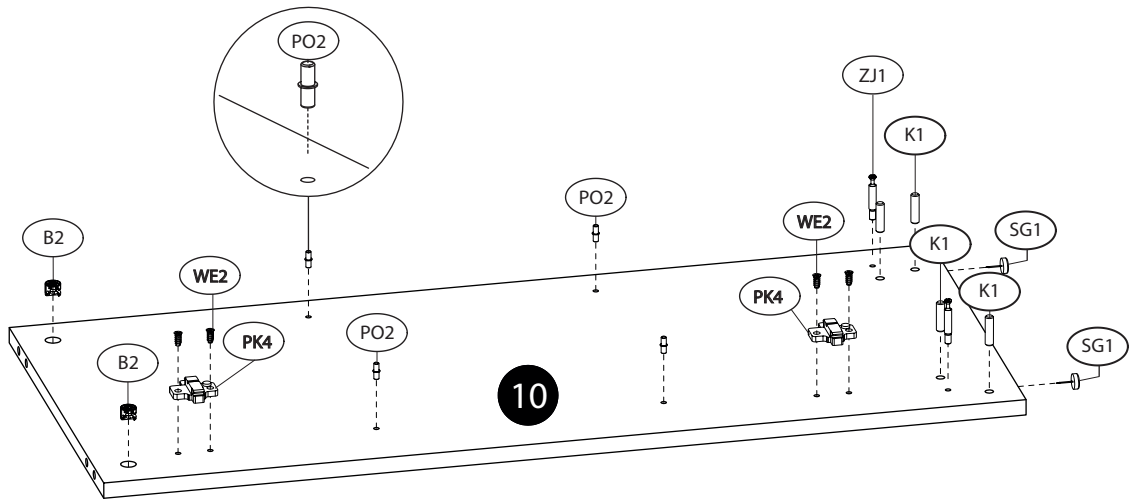
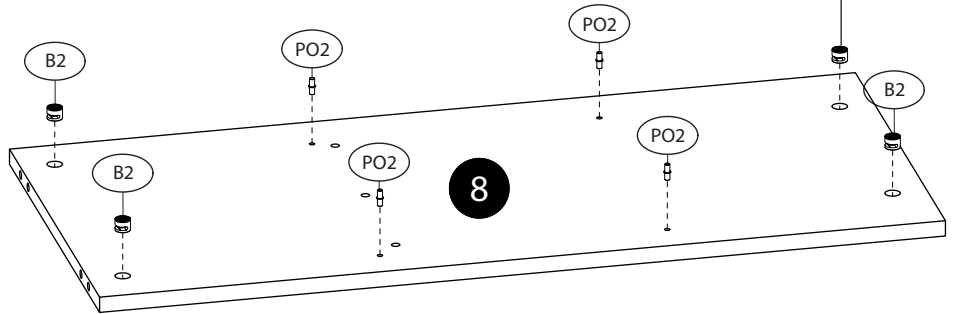
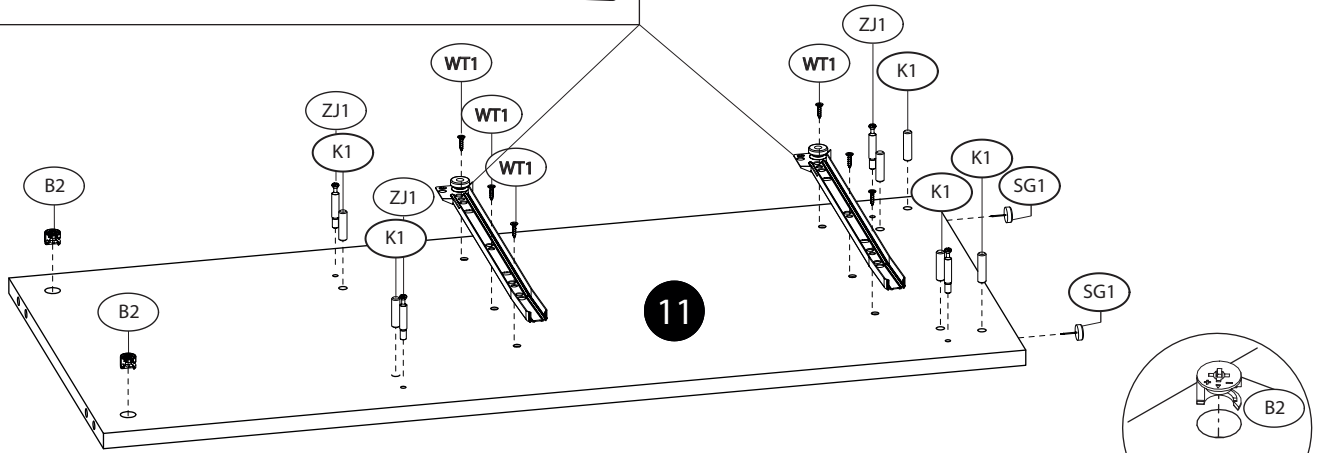
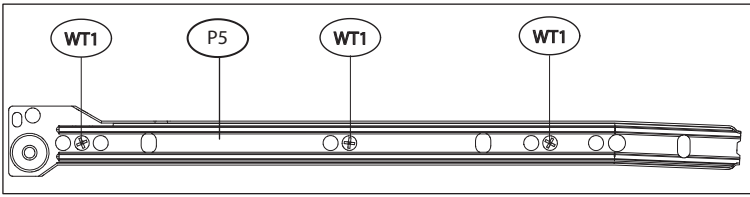
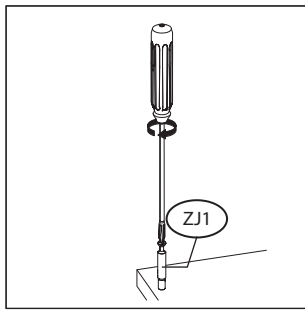
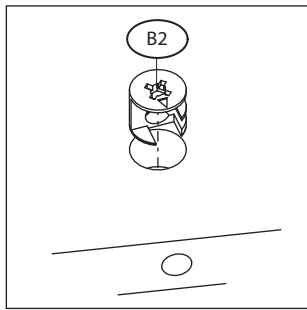
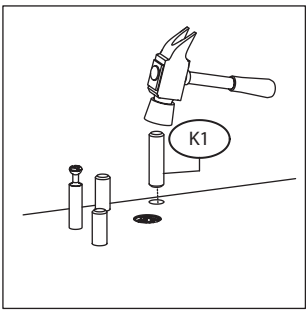

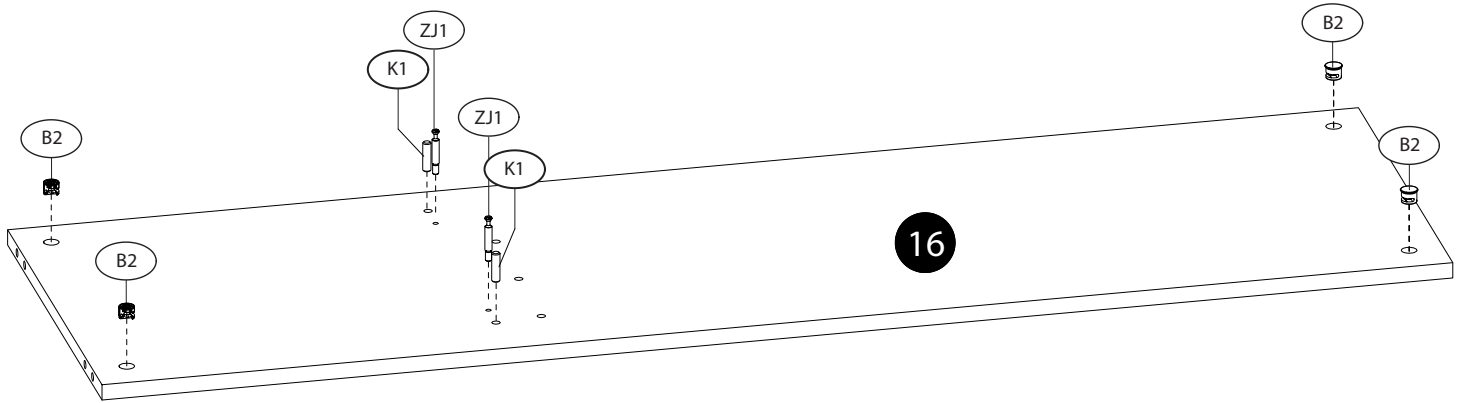
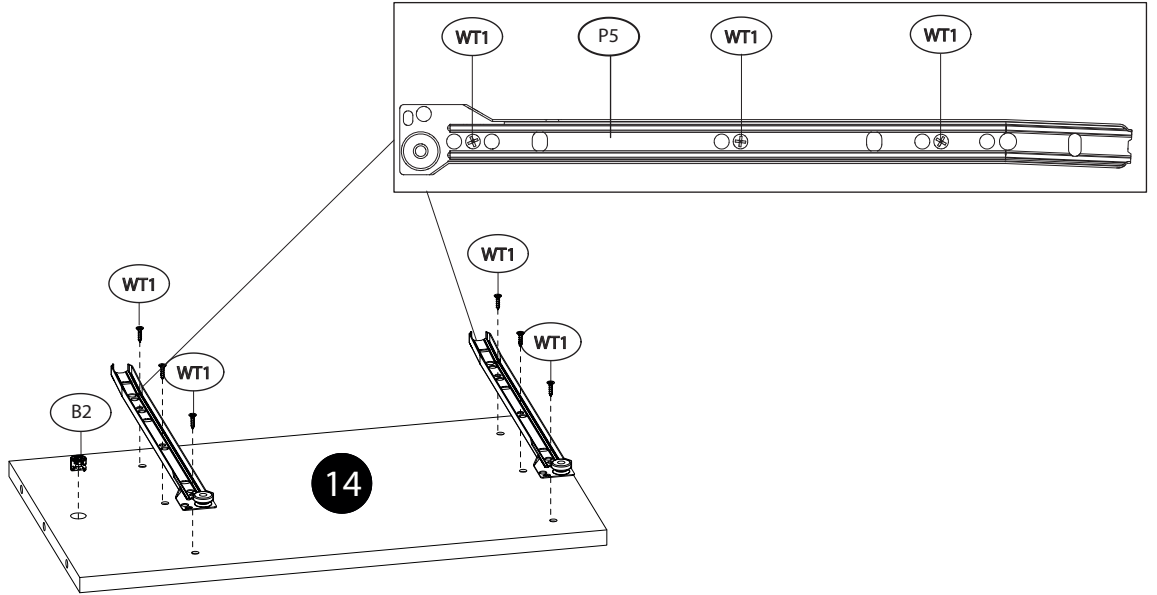
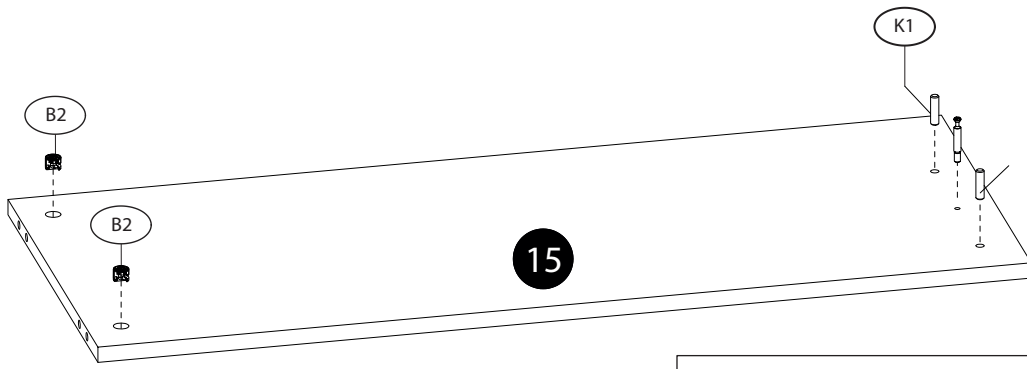

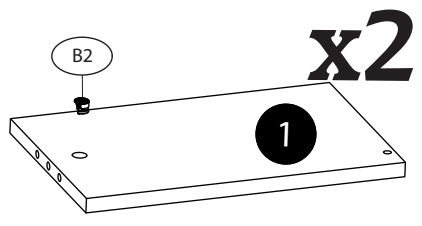
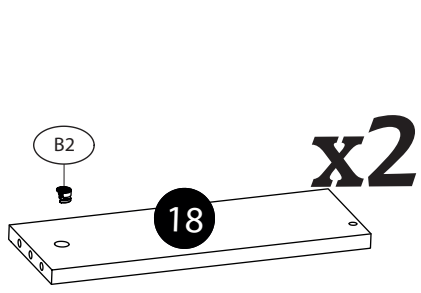
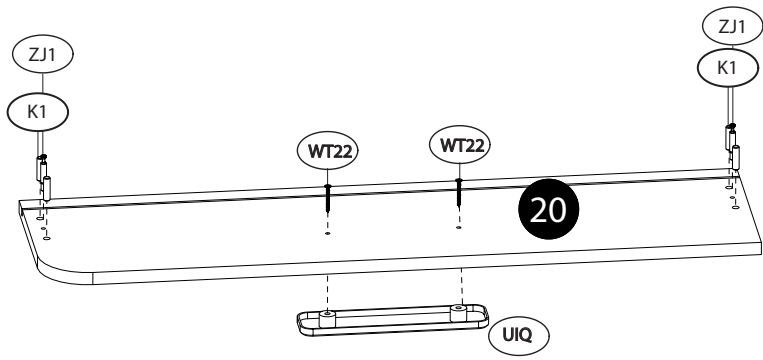
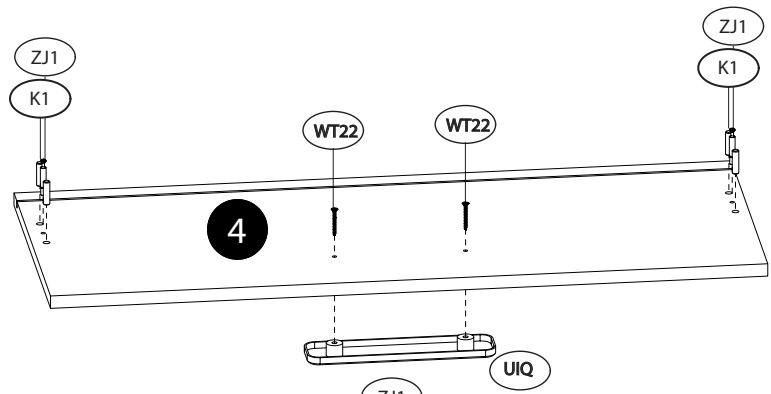
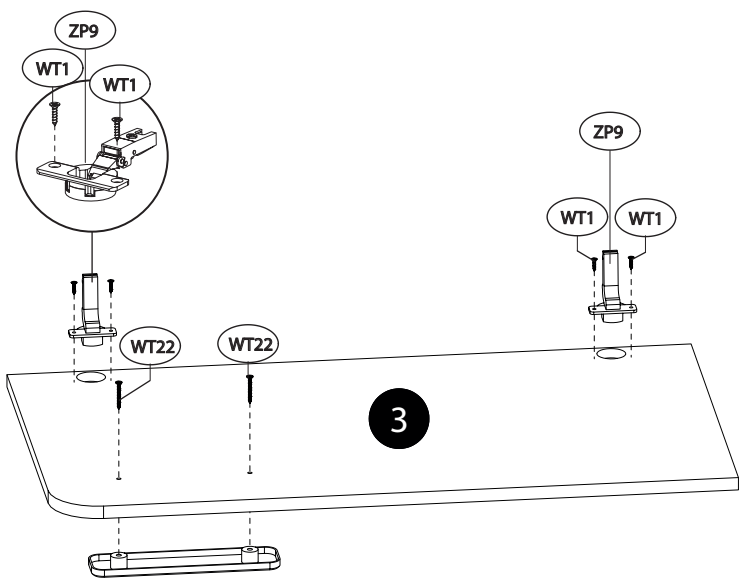
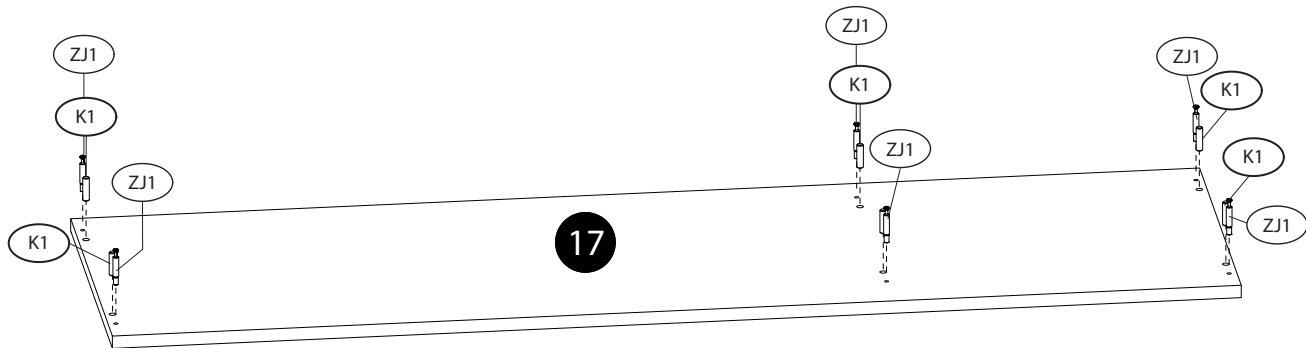

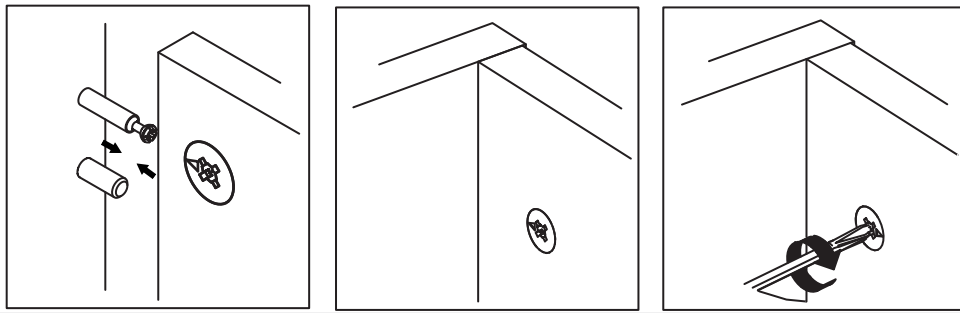

**A ▶**

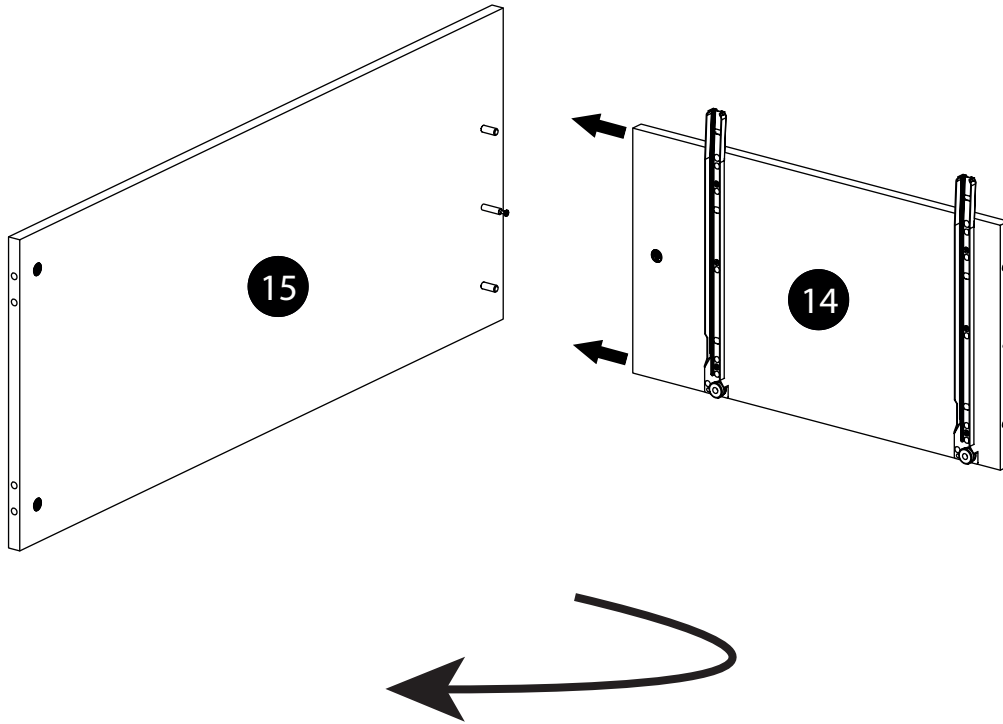

**B ▶**

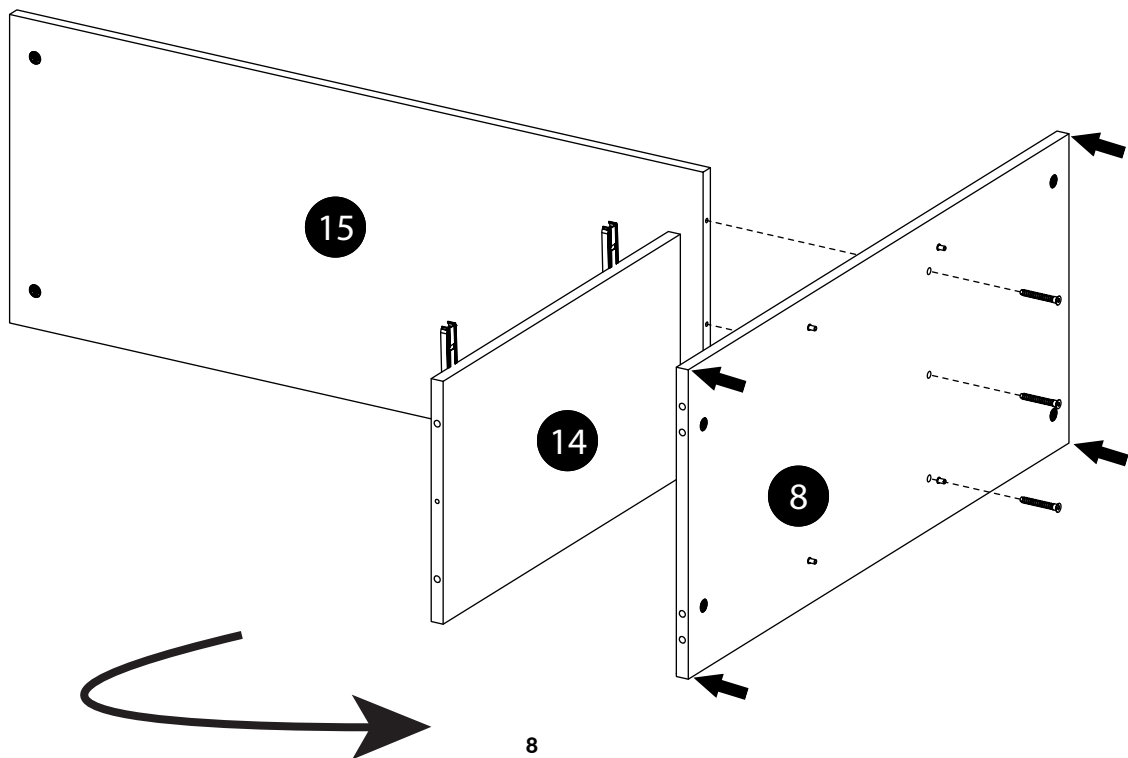



**C ▶**

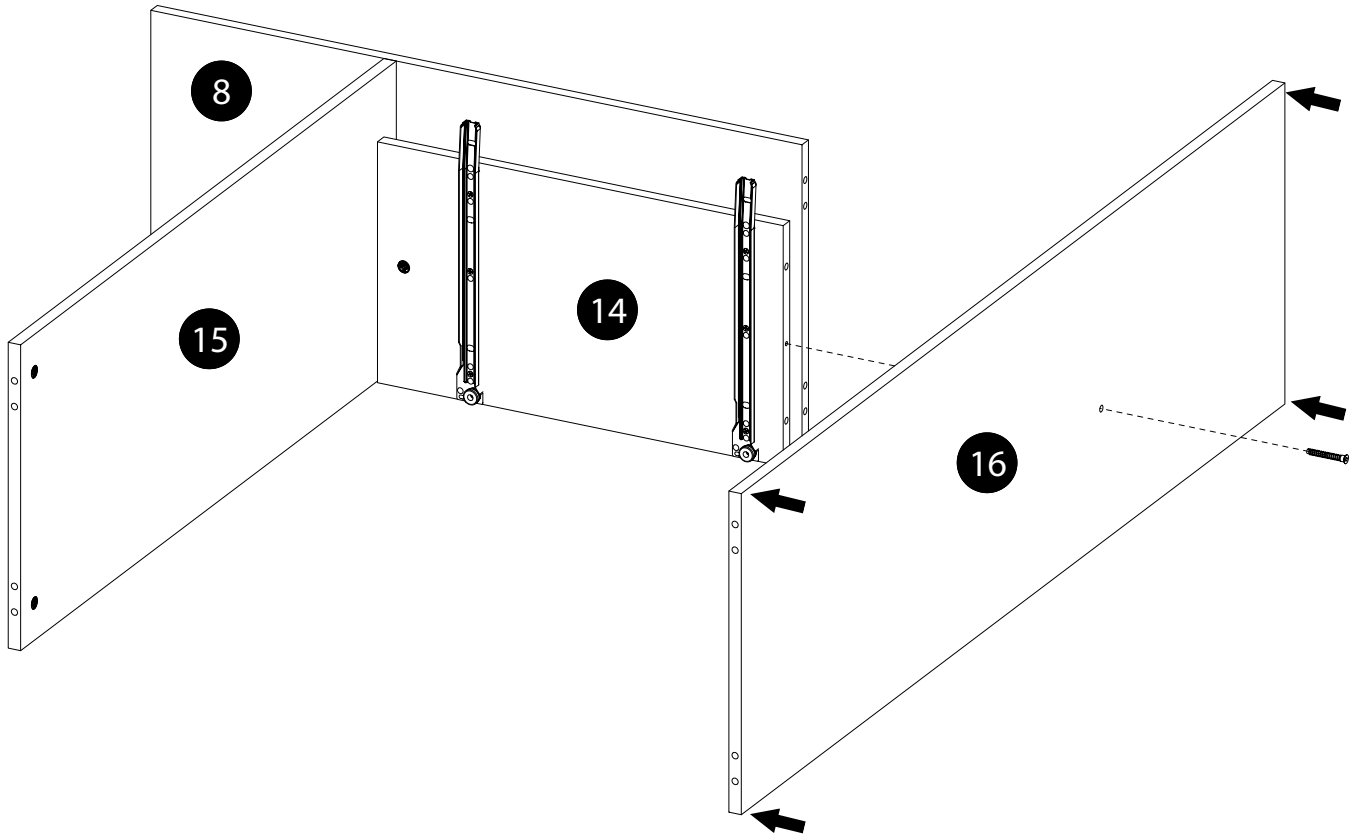

**D ▶**

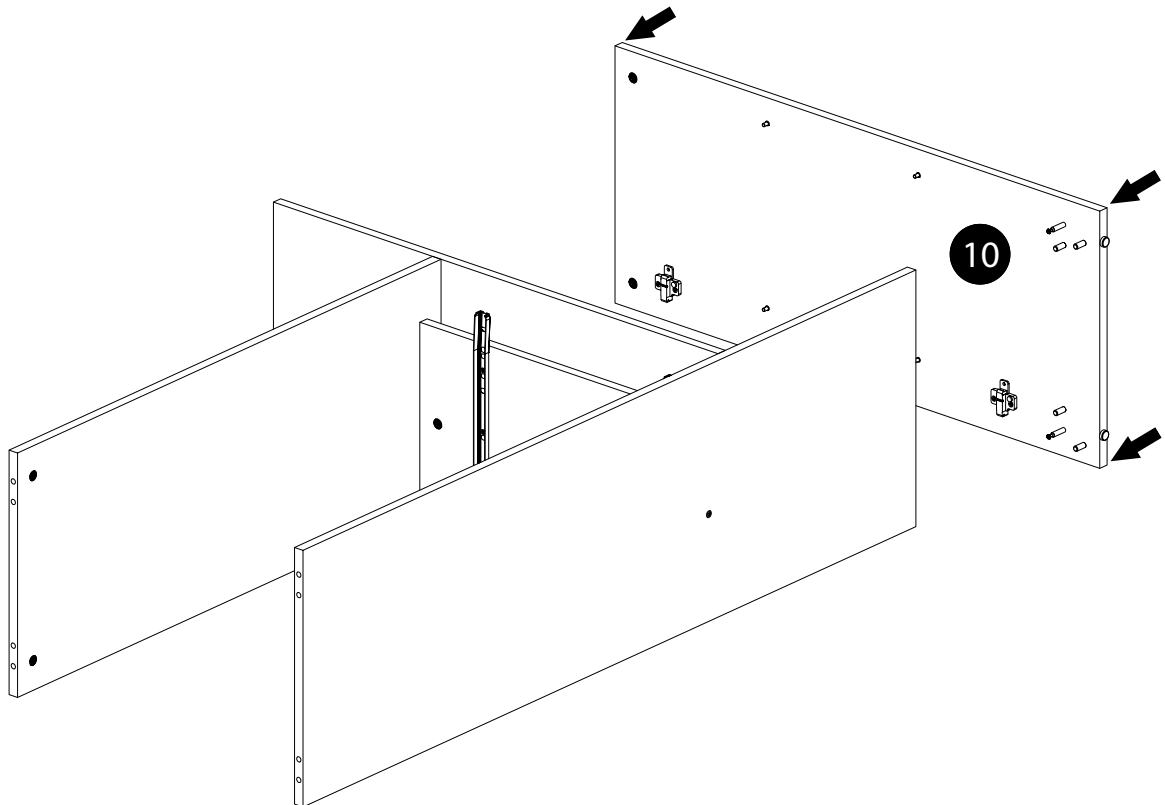

**E** ▶

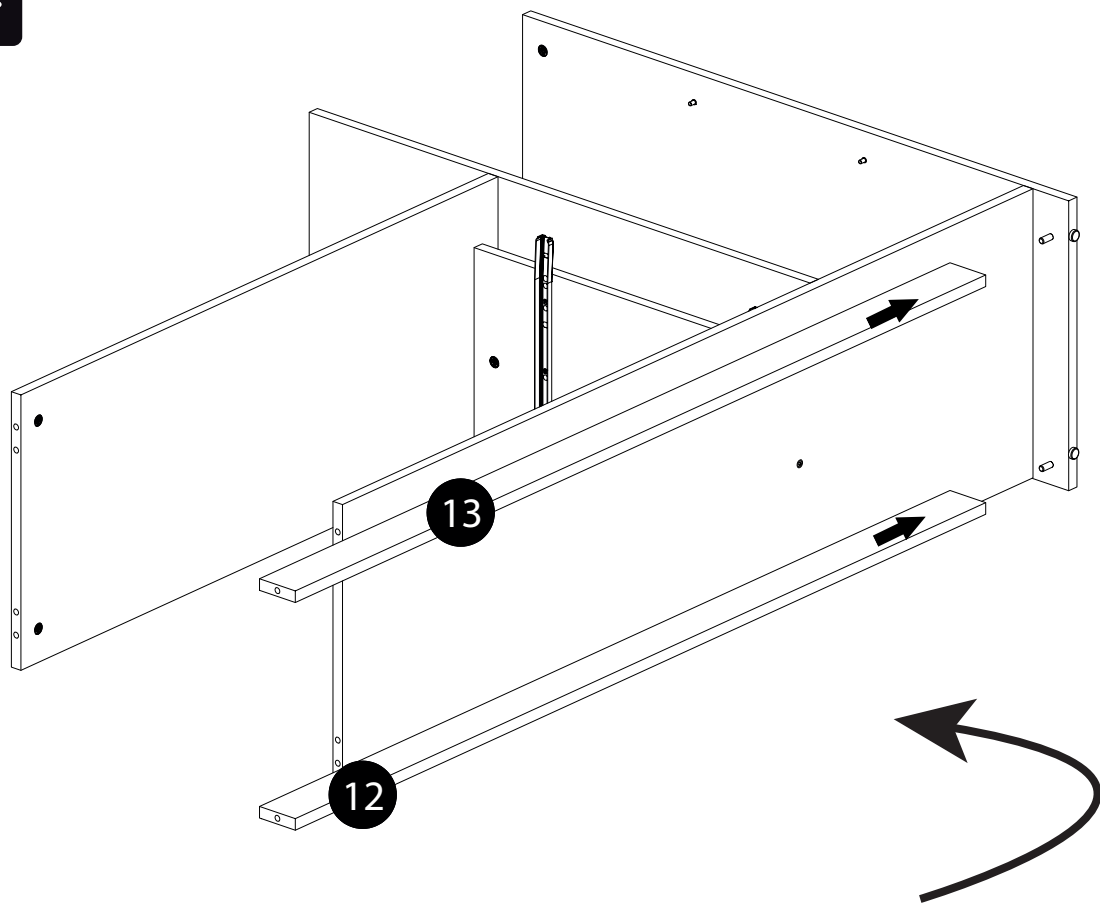

**F** ▶

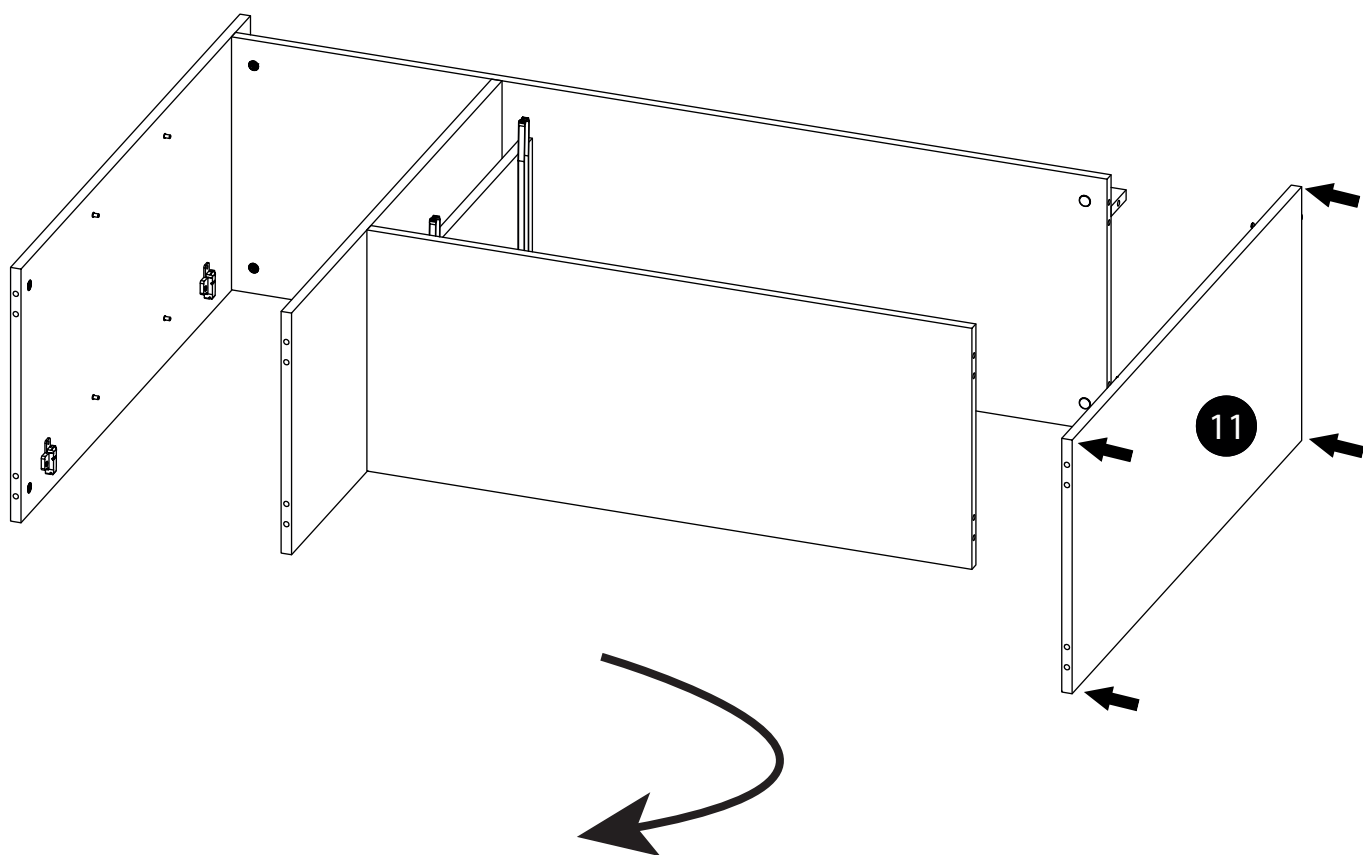

**G ▶**

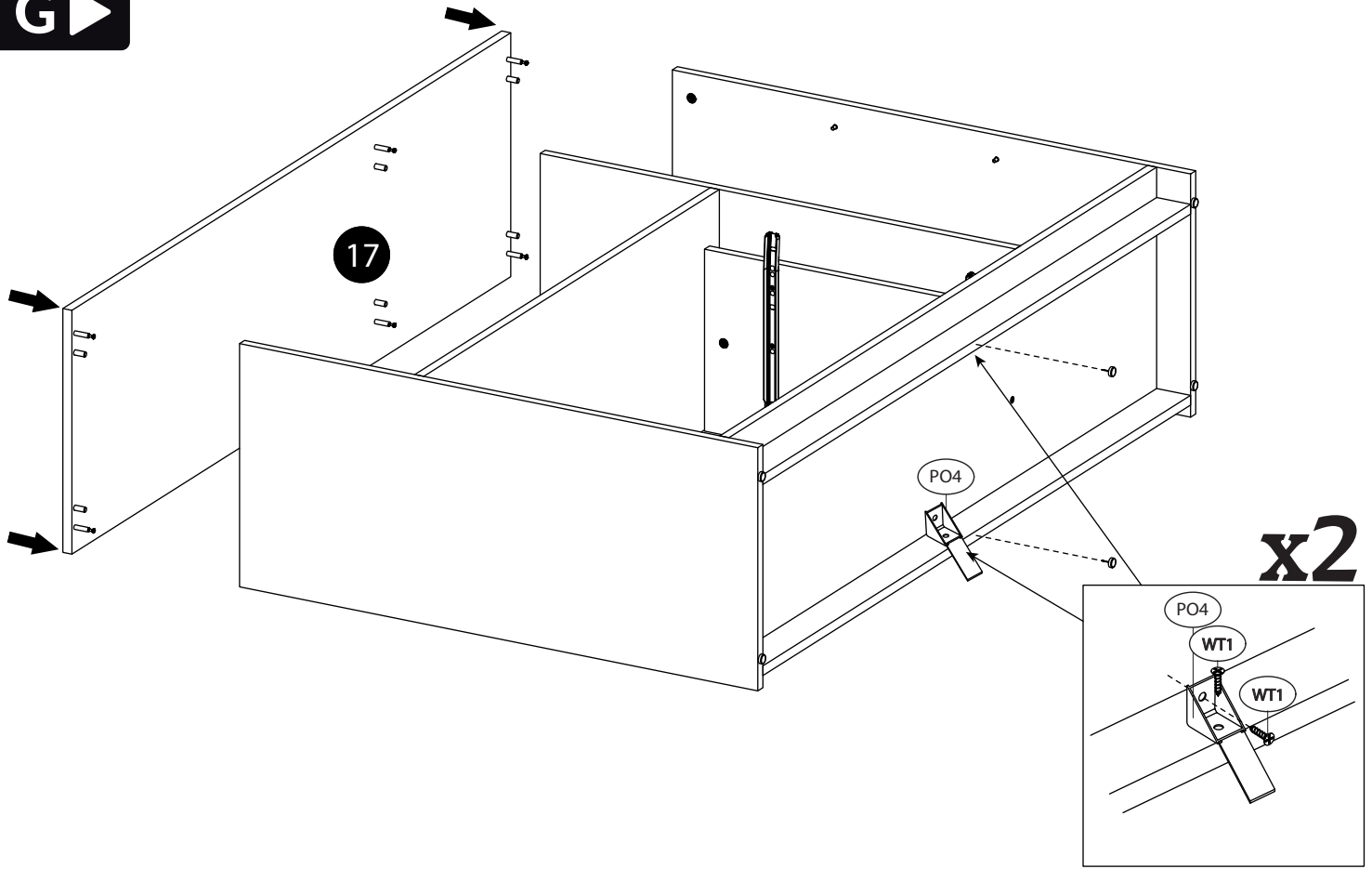

**H ▶**

