

GRANT 06

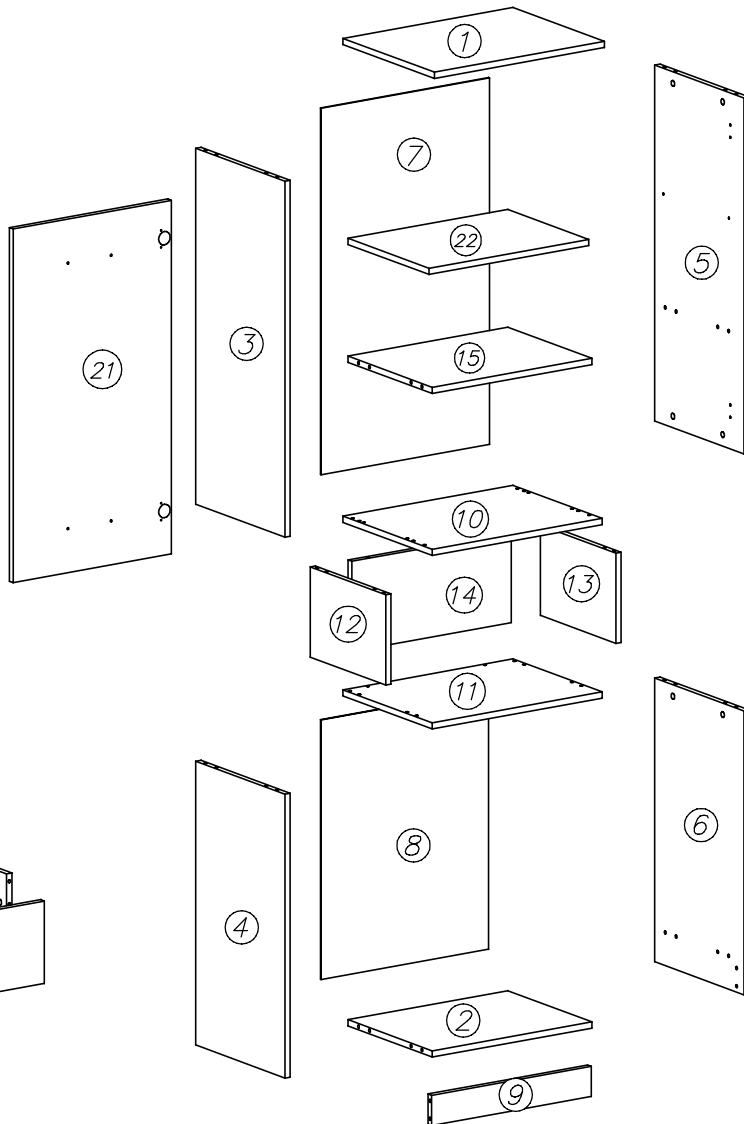

nr	L[mm]	B[mm]	T[mm]	Menge	Colli
1	520	400	16	1	3/3
2	488	368	16	1	3/3
3	923	390	16	1	2/3
4	736	390	16	1	2/3
5	923	390	16	1	2/3
6	736	390	16	1	2/3
7	947	512	2,5	1	1/3
8	673	512	2,5	1	1/3
9	488	78	16	1	1/3
10	520	390	16	1	2/3
11	520	390	16	1	2/3
12	234	330	16	1	2/3
13	234	330	16	1	2/3
14	234	486	16	1	1/3
15	488	368	16	1	3/3
16	484	214	16	3	1/3
17	350	170	16	3	1/3
18	350	170	16	3	1/3
19	430	150	16	3	1/3
20	443	358	2,5	3	1/3
21	918	484	16	1	1/3
22	488	360	16	1	1/3

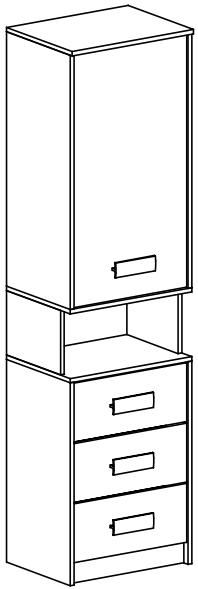
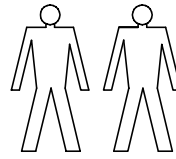
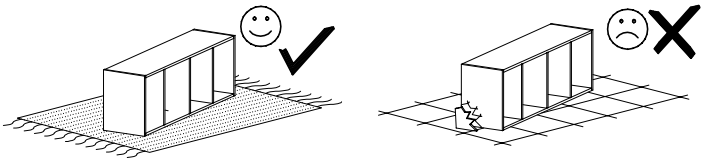
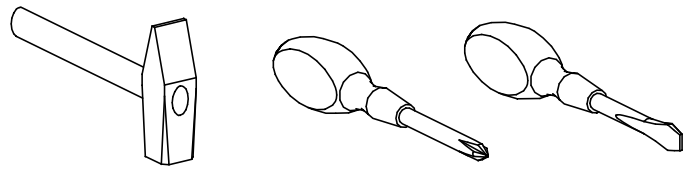
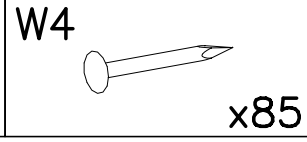
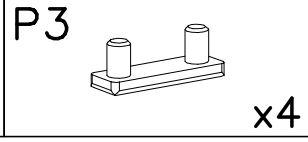
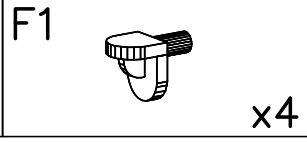
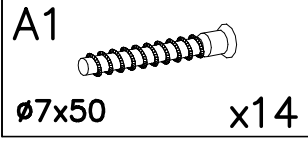
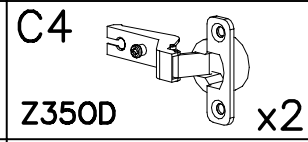
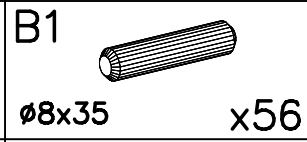
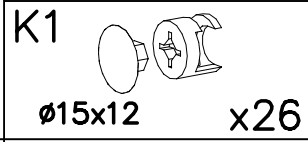
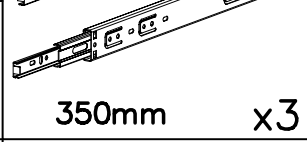
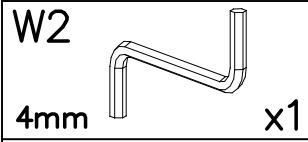
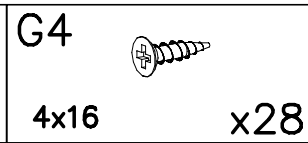
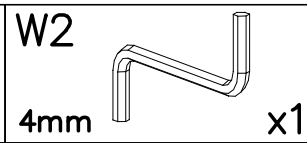
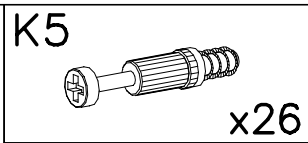
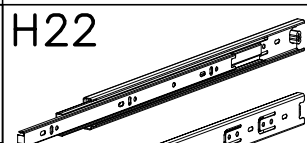
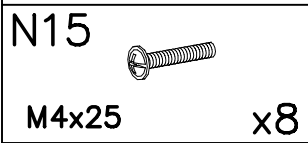
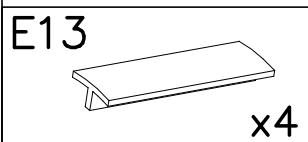

1

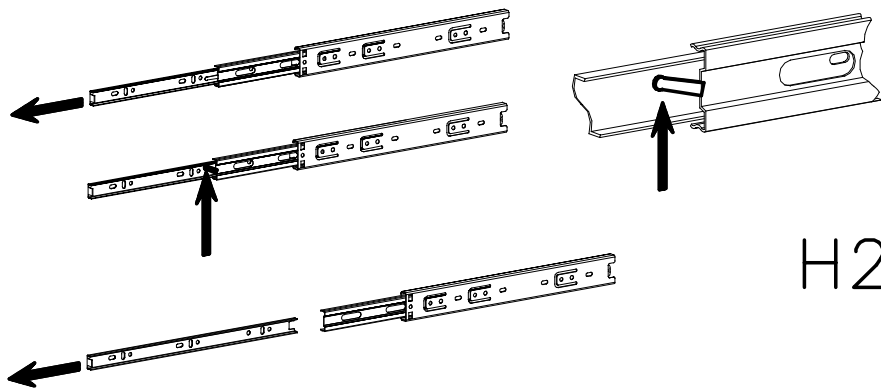
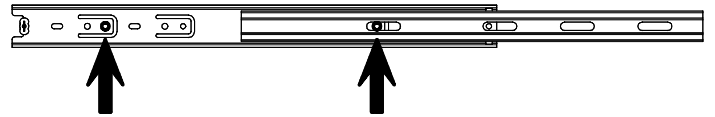
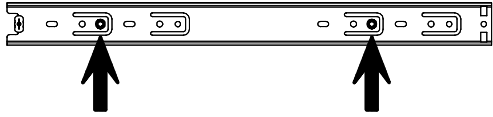
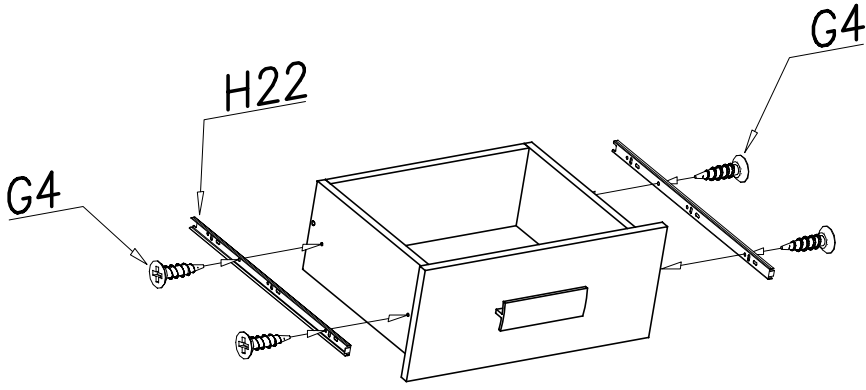
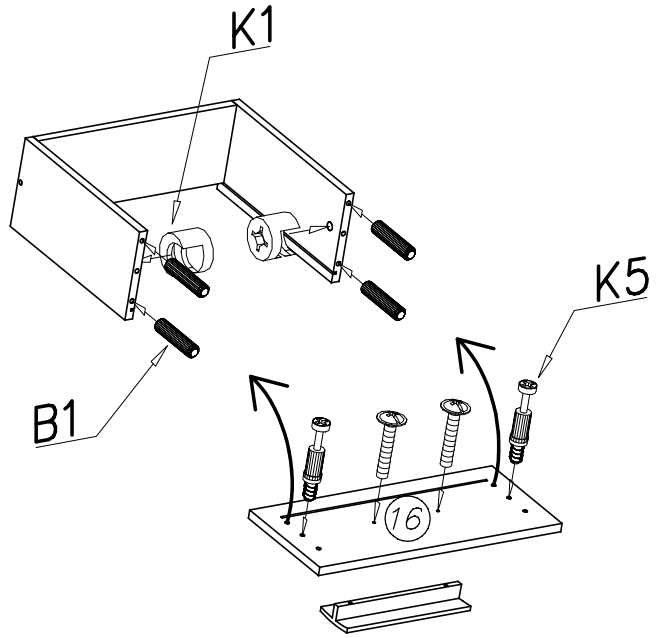
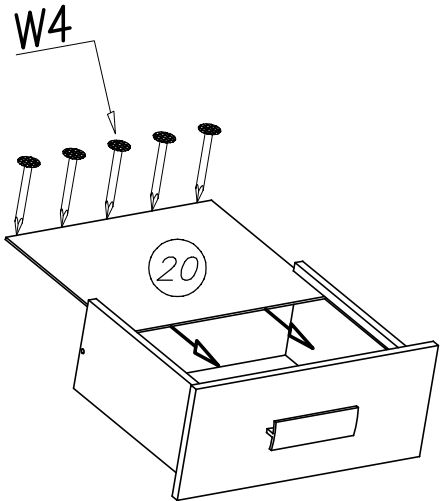
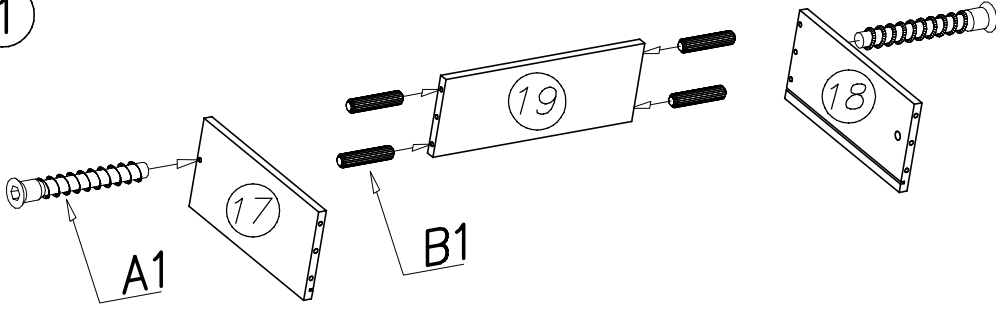

H22

2

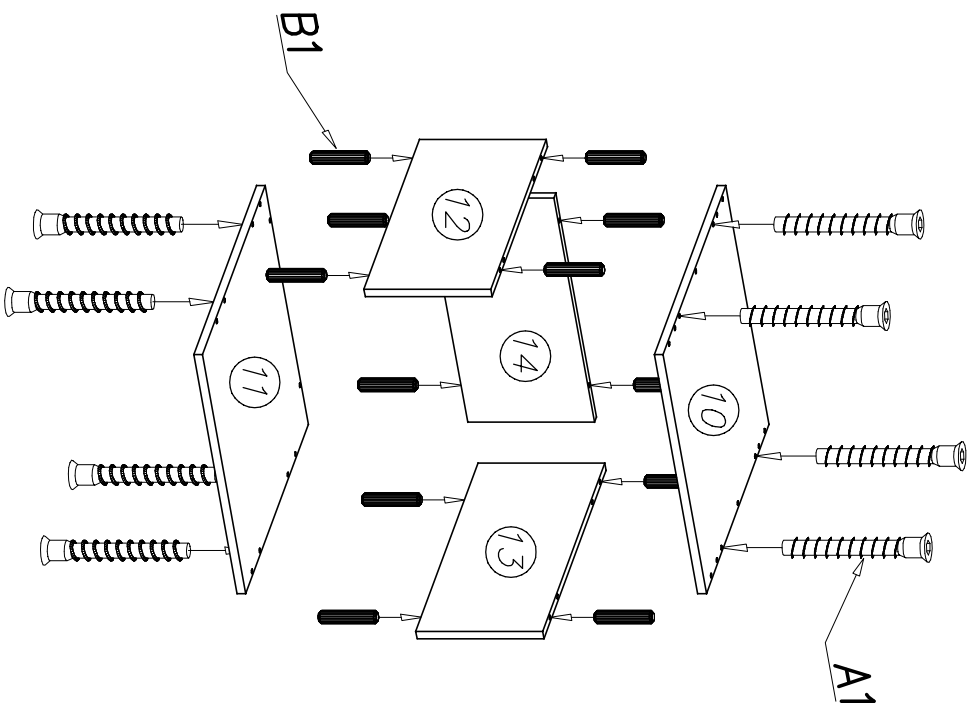

3

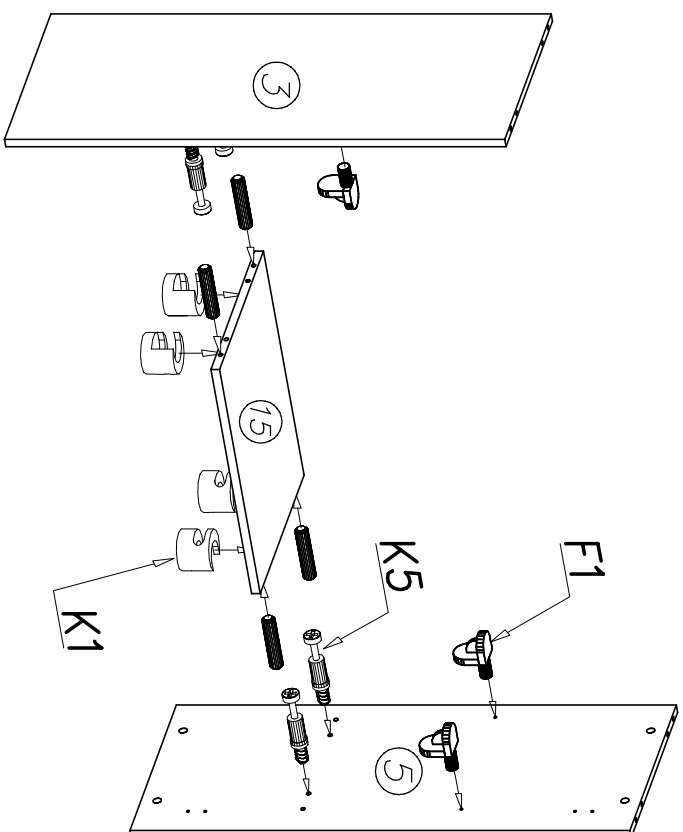

4

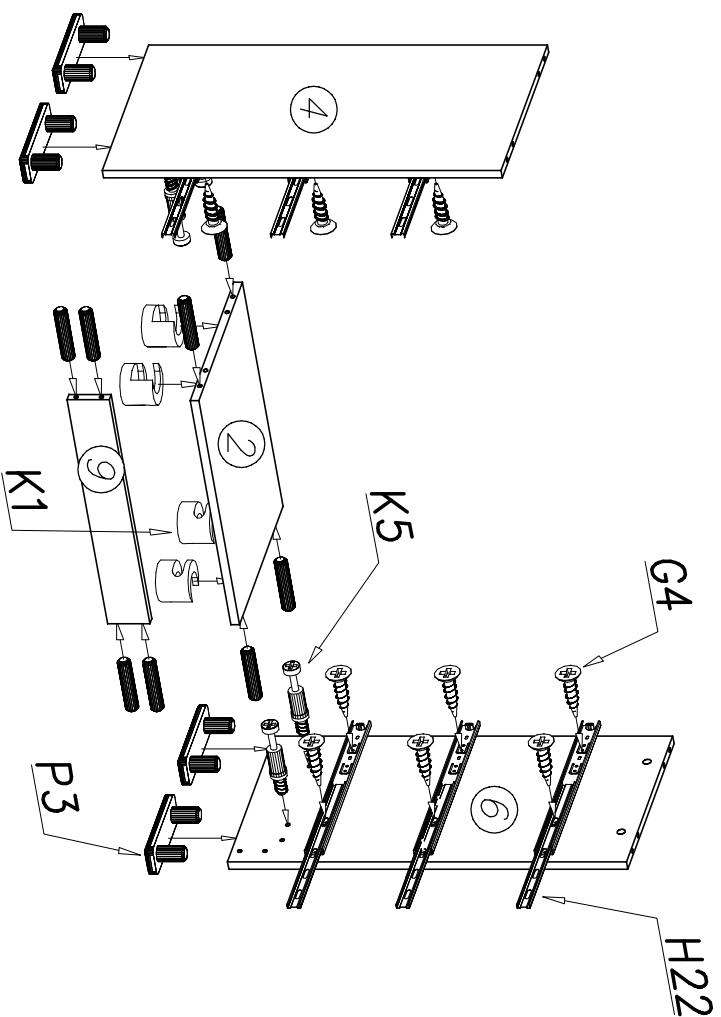

5

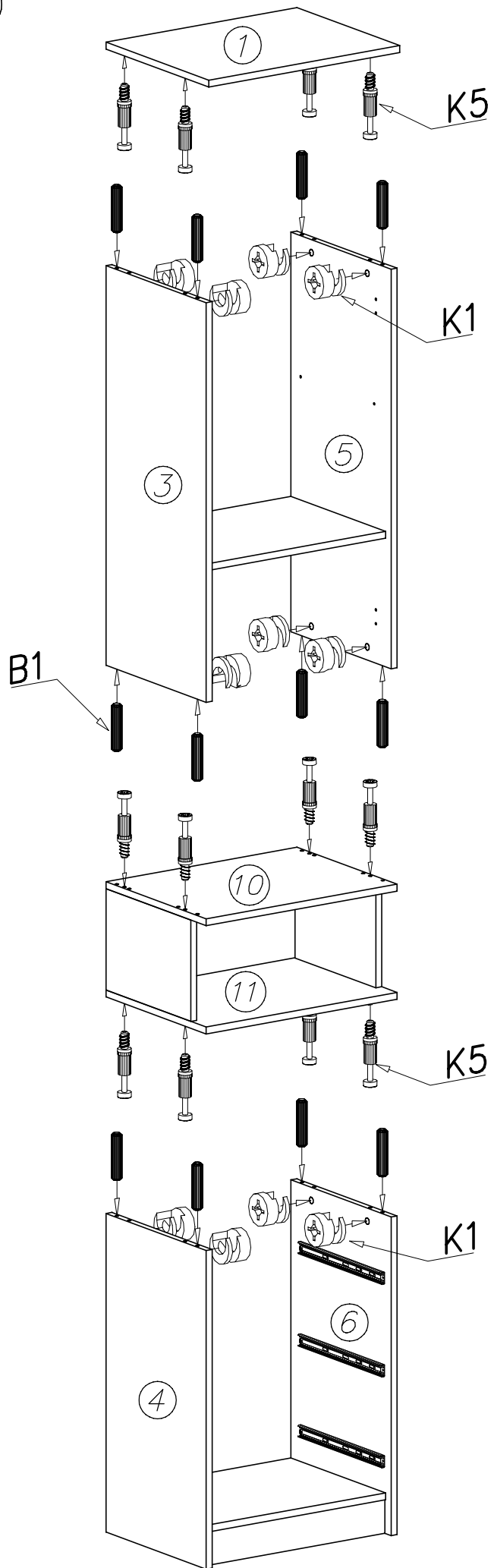

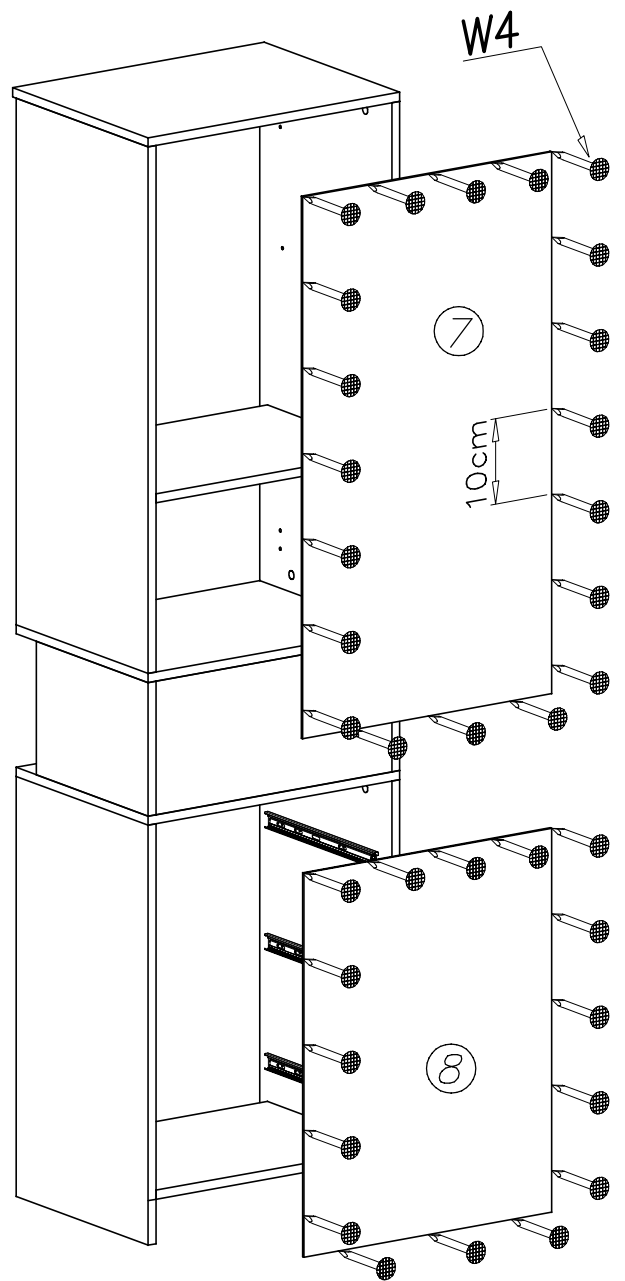

6

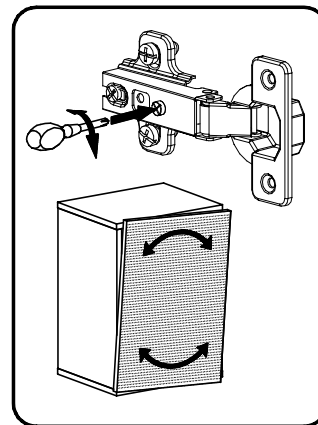
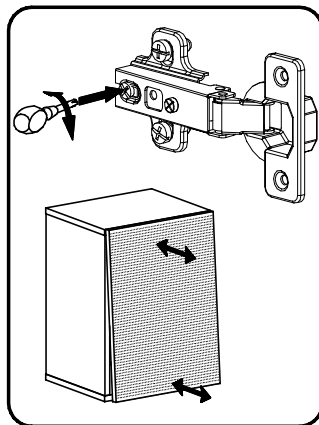
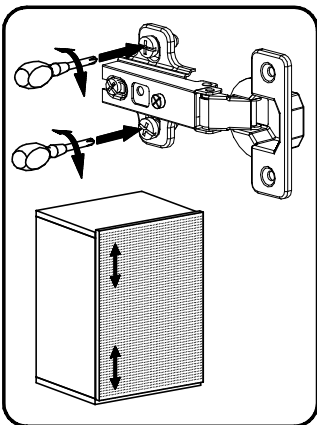
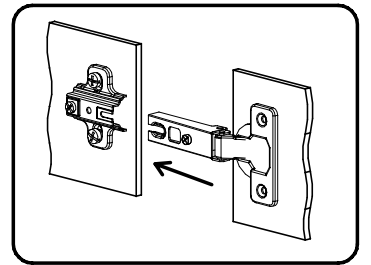
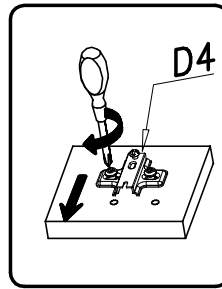
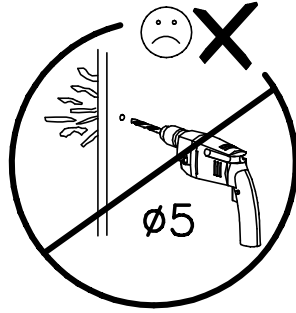
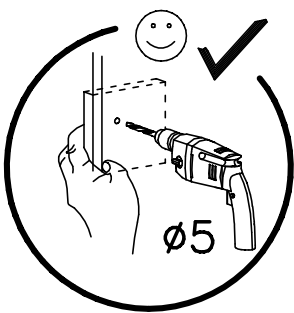
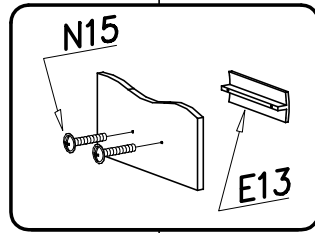
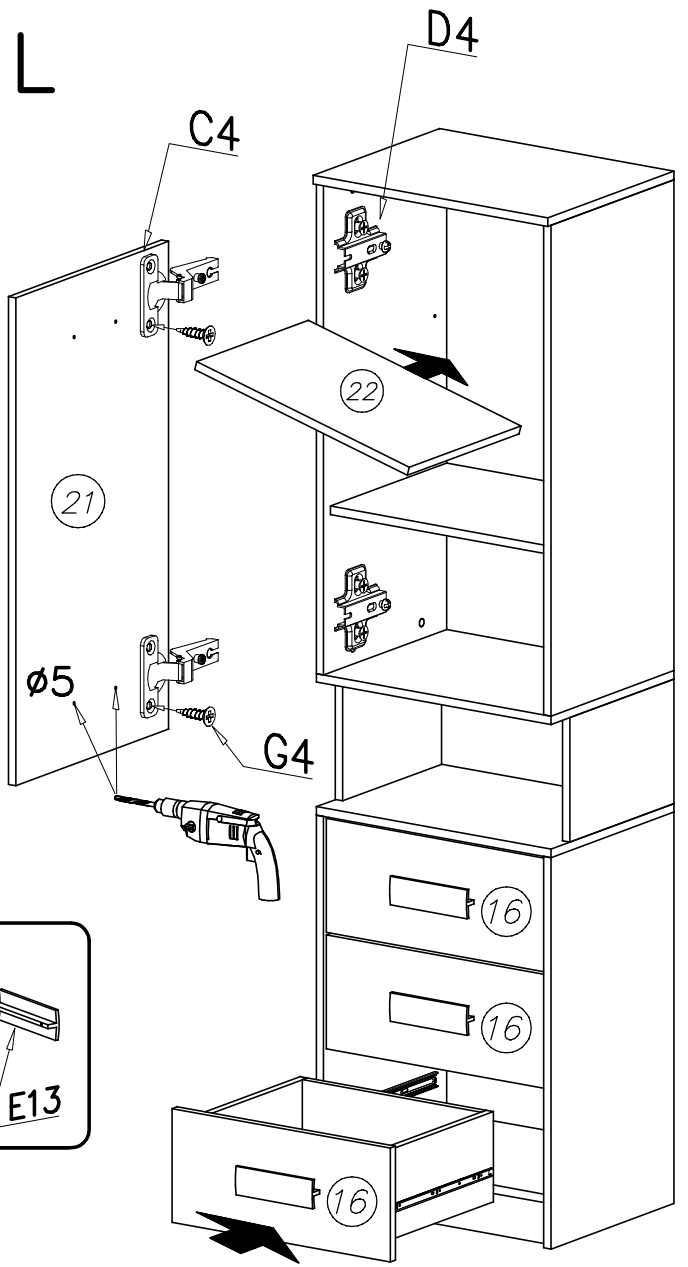
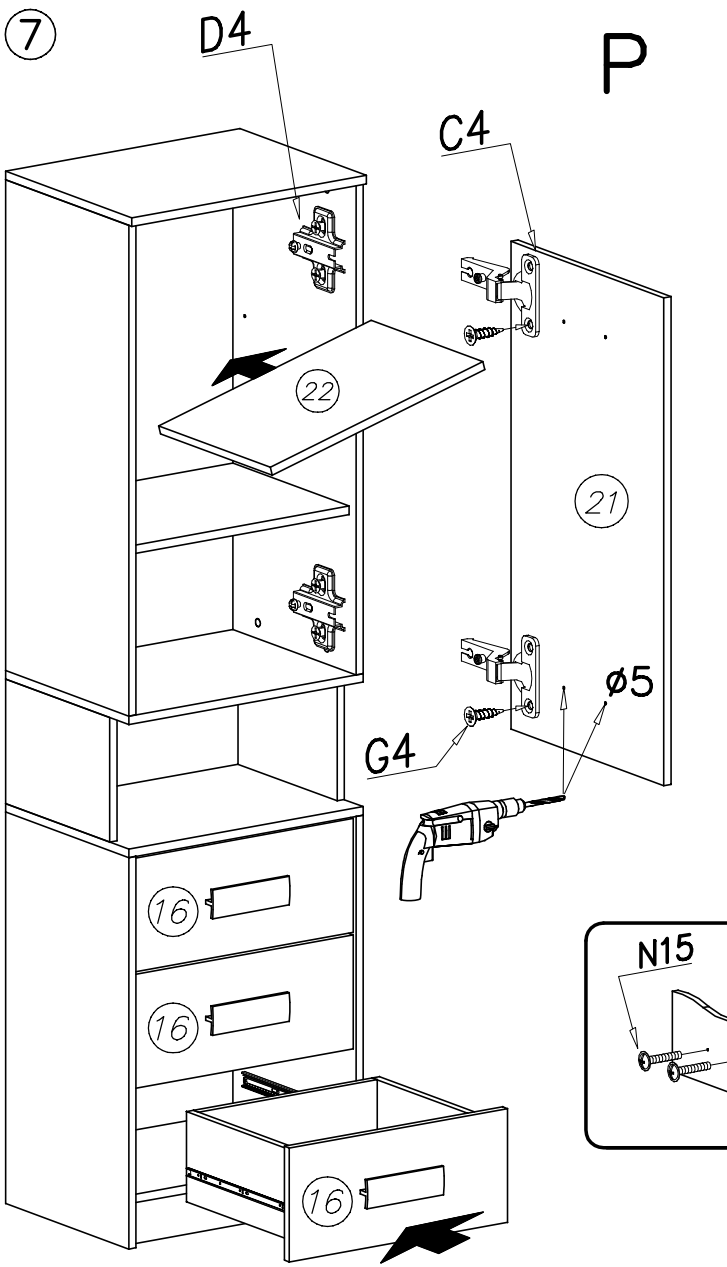

7

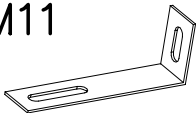

M11  x1	G22 4x16  x2
--	---

PL – Mocowanie mebla do ściany
 DE – Befestigung der Moebel an der Wand
 EN – Fixing the furniture to the wall

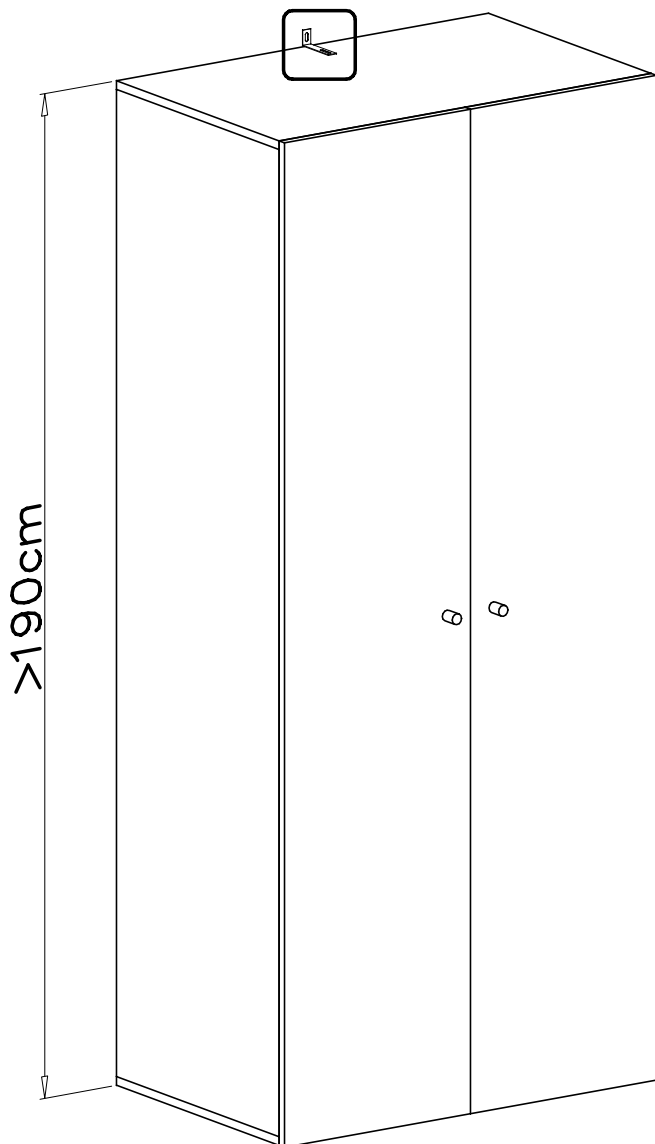
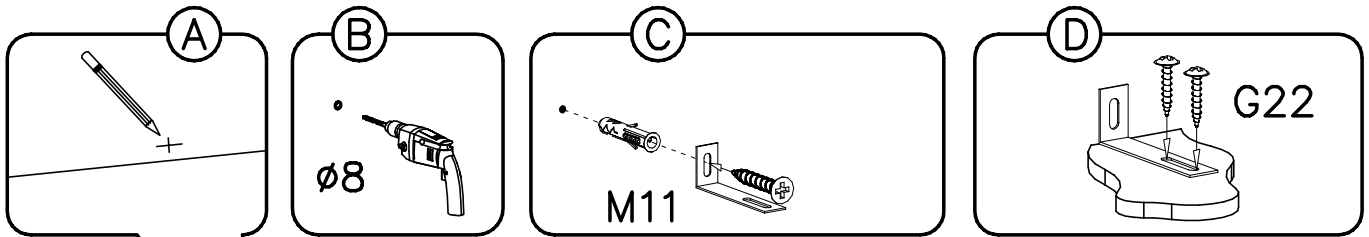

PL –
 Przed zawieszeniem mebla, lub przymocowaniem do ściany, sprawdź wcześniej rodzaj i wytrzymałość ściany. Dobierz odpowiednie kołki i wkręty do rodzaju ściany. W przypadku wątpliwości skontaktuj się ze specjalistą. Montaż musi zostać wykonany przez osobę kompetentną. Instalacja powinna być przeprowadzona zgodnie z instrukcjami producenta – w przeciwnym razie może pojawić się niebezpieczeństwo, że instalacja będzie nieprawidłowa, co może spowodować poważnie lub śmiertelne obrażenia ciała skutkiem przycięcia.

OSTRZEŻENIE !!! W celu uniknięcia przewrócenia się tego produktu należy używać go z dołączonym urządzeniem mocowania do ściany. Podczas użytkowania umieszczaj ciężkie przedmioty w dolnej części mebla, nie stawiaj na nim telewizora ani innych ciężkich przedmiotów oraz nigdy nie pozwalaj dzieciom spinać się na szuflady, dzwiczki i półki.

DE
 Bevor Sie die Moebel aufhaengen oder an der Wand befestigen, ueberpruefen Sie vorher den Wandtyp und die Staerke. Waehlen Sie die geeigneten Duebel und Schrauben fuer den Schrauben fuer den Wandtyp. Wenden Sie sich im Zweifelsfall an einen Spezialisten. Die Installation muss von einer konetenten Person durch gefuehrt werden. Die Installation sollte gemaess den Anweisungen des Herstellers durchgefuehrt werden. Andernfalls besteht die Gefahr, dass die Installation falsch ist, was zu schweren oder toedlichen Verletzungen durch Quetschen fuehewn kann.
 ACHTUNG !!! Verwenden Sie das mitgelieferte Wandbefestigungsgeraet, um ein Umkippen des Produkts zu verhindern, Stellen Sie beim Gebrauch schwere Gegenstaende in den Boden der Moebel, stellen Sie den Fernseher oder andere schwere Gegenstaende nicht darauf und lassen Sie Kinder niemals auf Schubladen, Tueren und Regale klettern.

EN
 Before hanging the furniture or attaching it to the wall, check the wall type and strength beforehand. Choose the appropriate dowels and screws for the wall type. If in doubt, contact a specialist. Installation should be carried out in accordance with the manufacturer's instructions – otherwise there may be a danger that the installation will be incorrect, which can cause serious or fatal injury due to crushing.
 WARNING!!! To prevent the product from tipping over, use it with the wall attachment device included. when using, place heavy objects one the bottom of the furniture, do not place the TV or other heavy objects on it, and never allow children to climb on drawers, doors and shelves.

