

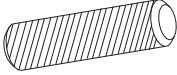









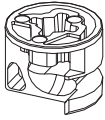
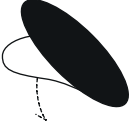

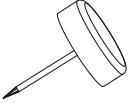
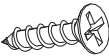
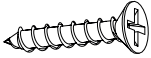
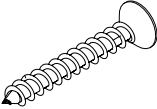
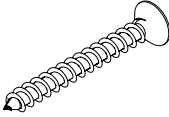
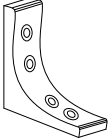
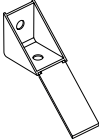
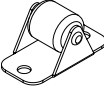
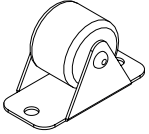
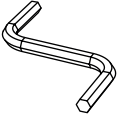
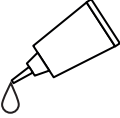
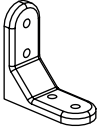
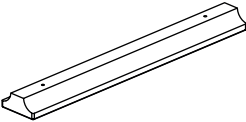
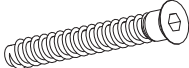
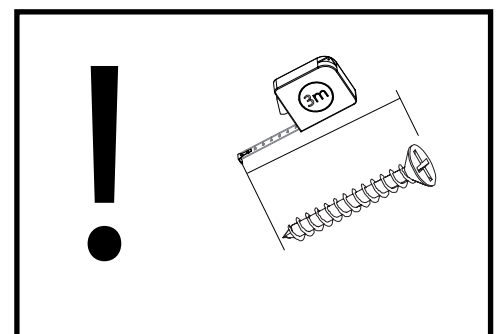
# DROP 17

<p><b>K1</b> x 24 8x32</p> 	<p><b>ZJ1</b> x 30 L-43</p> 	<p><b>B2</b> x 30 h-12</p> 
<p><b>ZS2</b> x 8 Ø20</p> 	<p><b>ZS1</b> x 14 Ø13</p> 	<p><b>WT7</b> x 4 3x10</p> 
<p><b>SG1</b> x 6</p> 	<p><b>WT1</b> x 32 3,5x15</p> 	<p><b>WT4</b> x 8 3,5x20</p> 
<p><b>WT18</b> x 48 4x30</p> 	<p><b>WT22</b> x 26 4x35</p> 	<p><b>KW9</b> x 2 75x75x20</p> 
<p><b>PO4</b> x 2</p> 	<p><b>RP-22</b> x 8</p> 	<p><b>RP-33/G</b> x 8</p> 
<p>x 1</p> 	<p><b>KL</b> x 1</p> 	<p><b>KW7</b> x 4 50x50</p> 
<p><b>UDR</b> x 2 L- 800</p> 	<p><b>KT1</b> x 8 6,3x50</p> 	



# DROP 17

	CODE				
1	Drop17K_08	1000	400	1	1/4K
2	Drop17K_04	2002	168	2	3/4K
3	Drop17K_05	900	108	2	1/4K
4	Drop17K_06	990	80	2	2/4K
5	Drop17K_12	758	168	2	2/4K
6	Drop17K_13	914	168	2	1/4K
7	Drop17K_07	1000	400	1	1/4K
8	Drop17K_09	997	397	1	1/4K
9	Drop17K_11	758	168	2	2/4K
10	Drop17K_10	946	758	2	2/4K

	CODE				
11	Drop17K_14	882	50	4	1/4K
12	Drop17K_01	807	970	1	2/4K
13	Drop17K_02	970	403	1	1/4K
14	Drop17K_03	932	284	1	1/4K
15	Drop17W_01	997	397	1	1/1W
16					
17					
18					
19					
20					

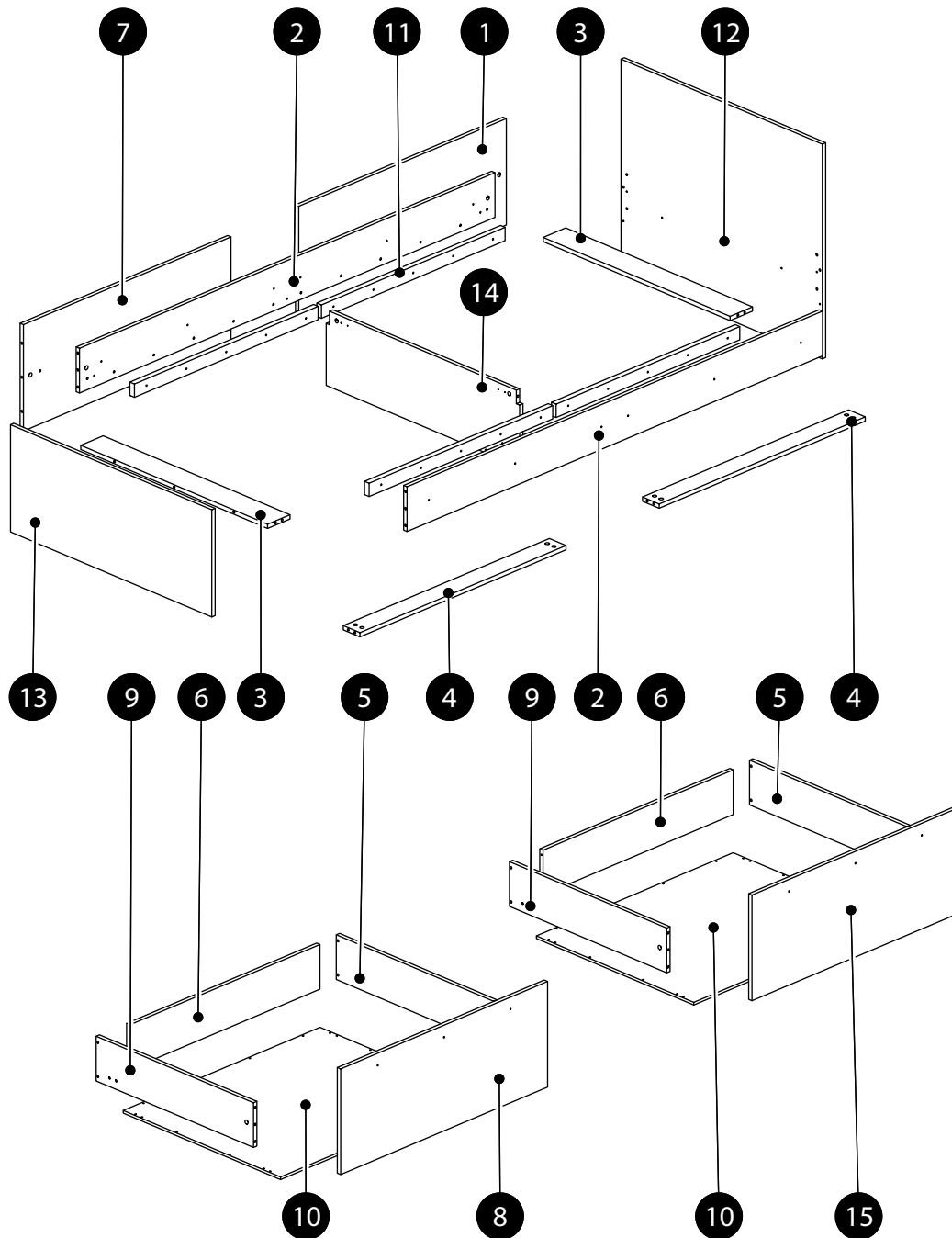

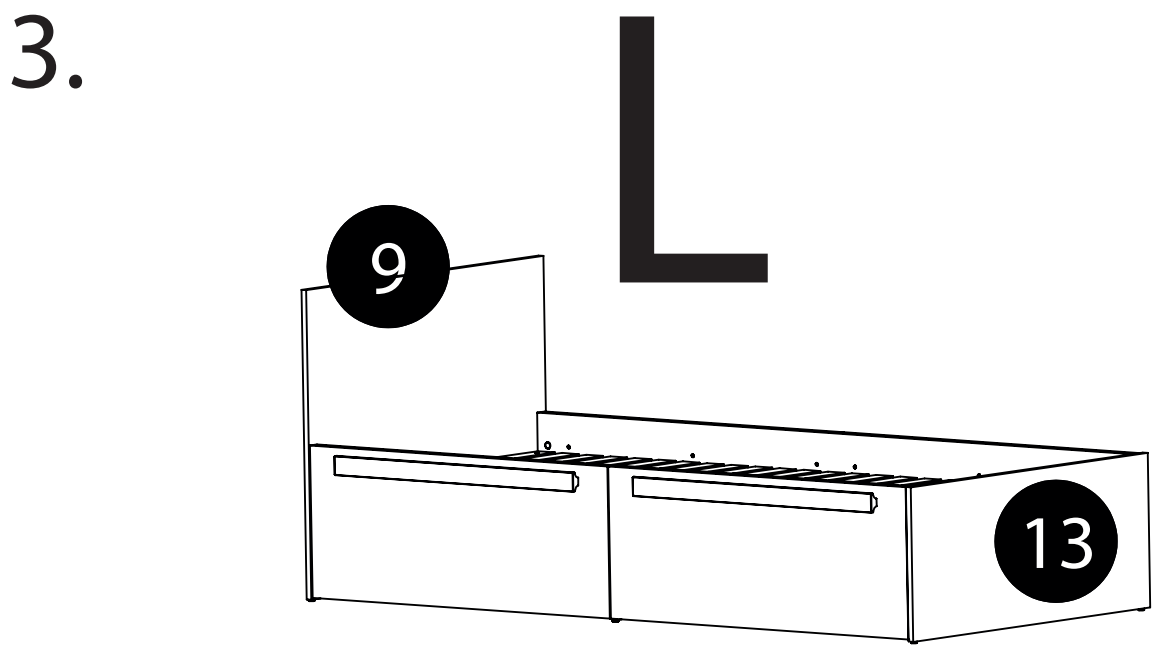
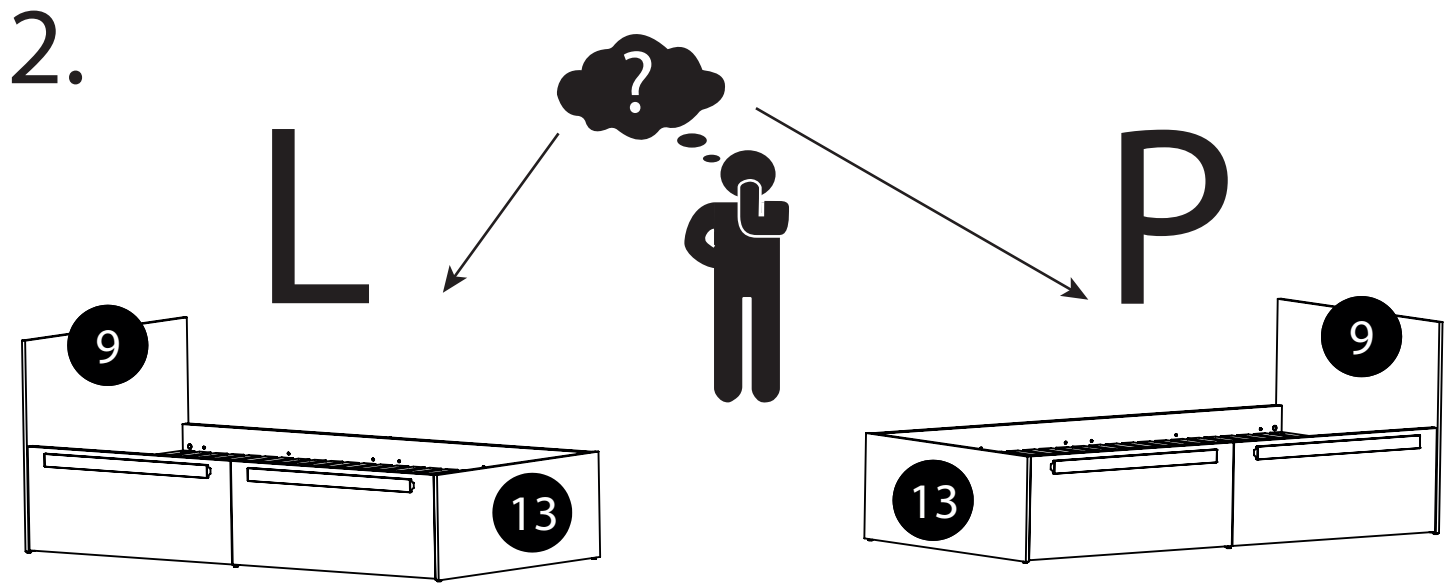
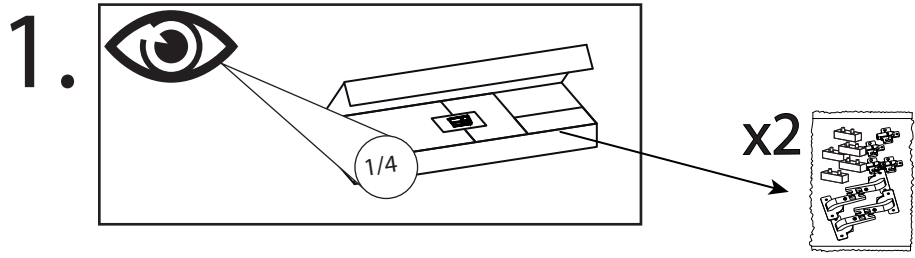

# 4.

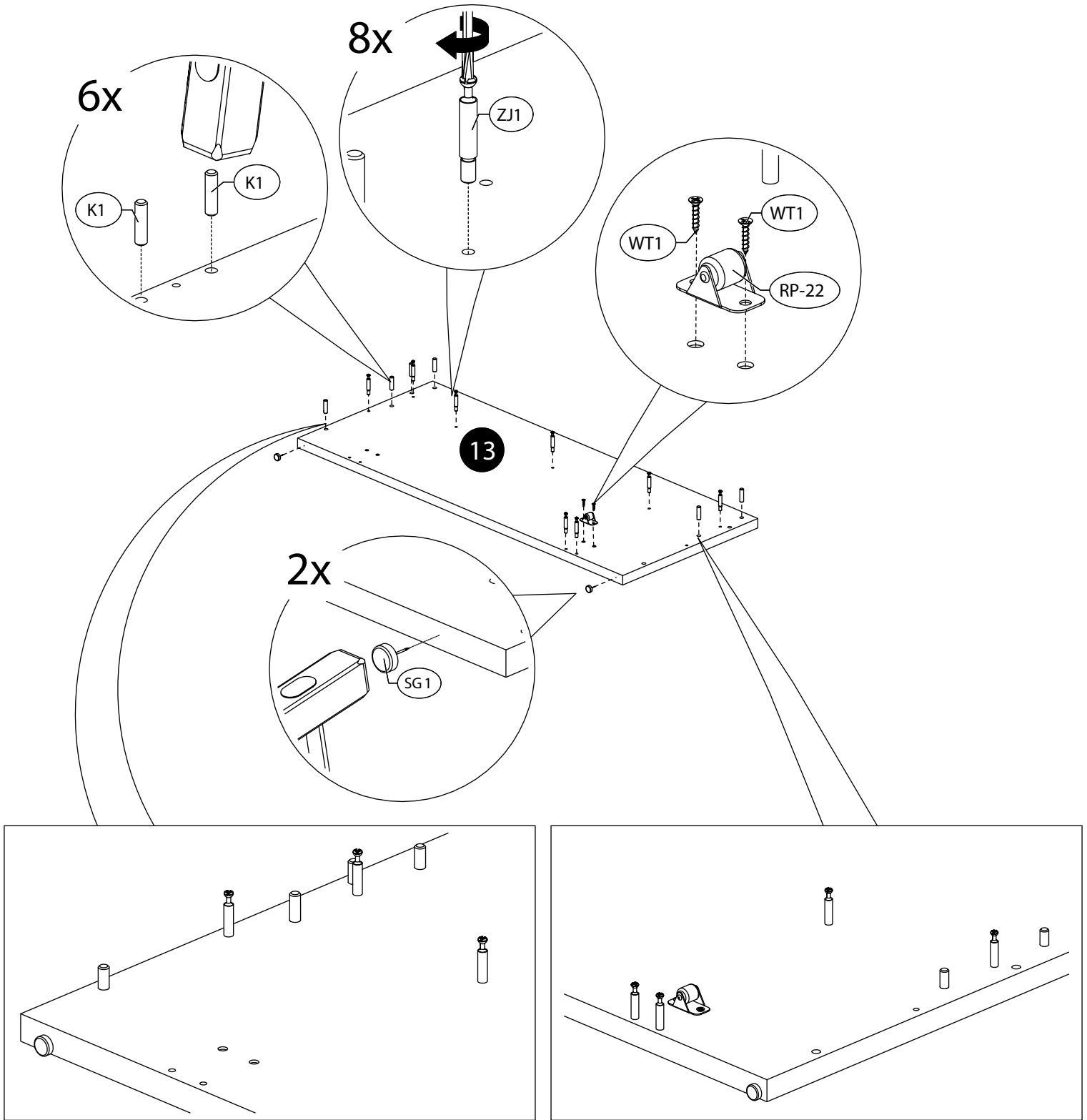

5.

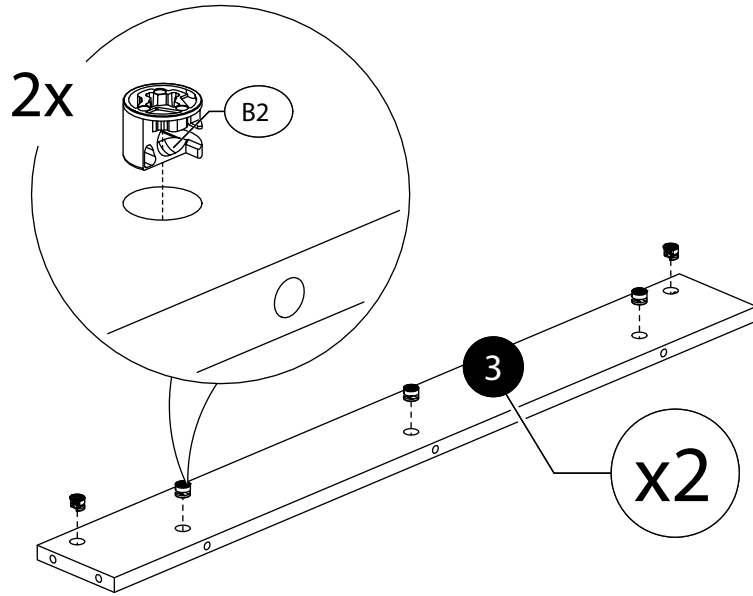

6a.

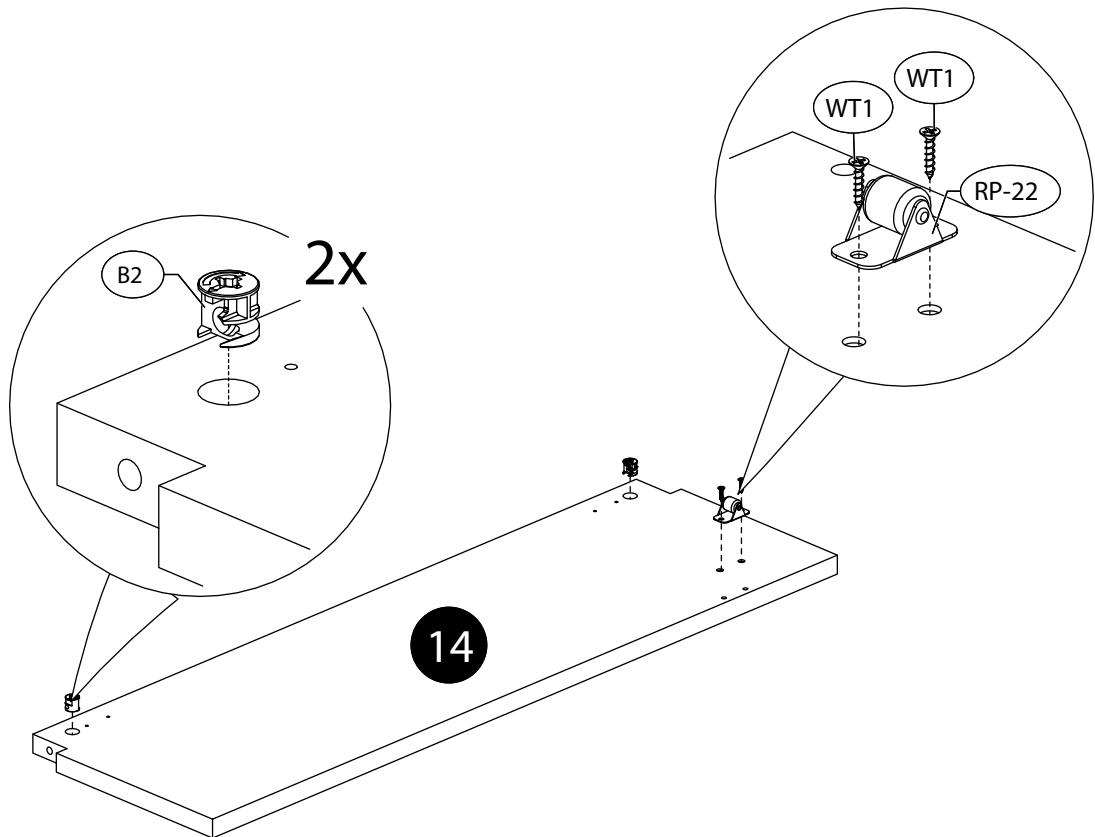

6b.

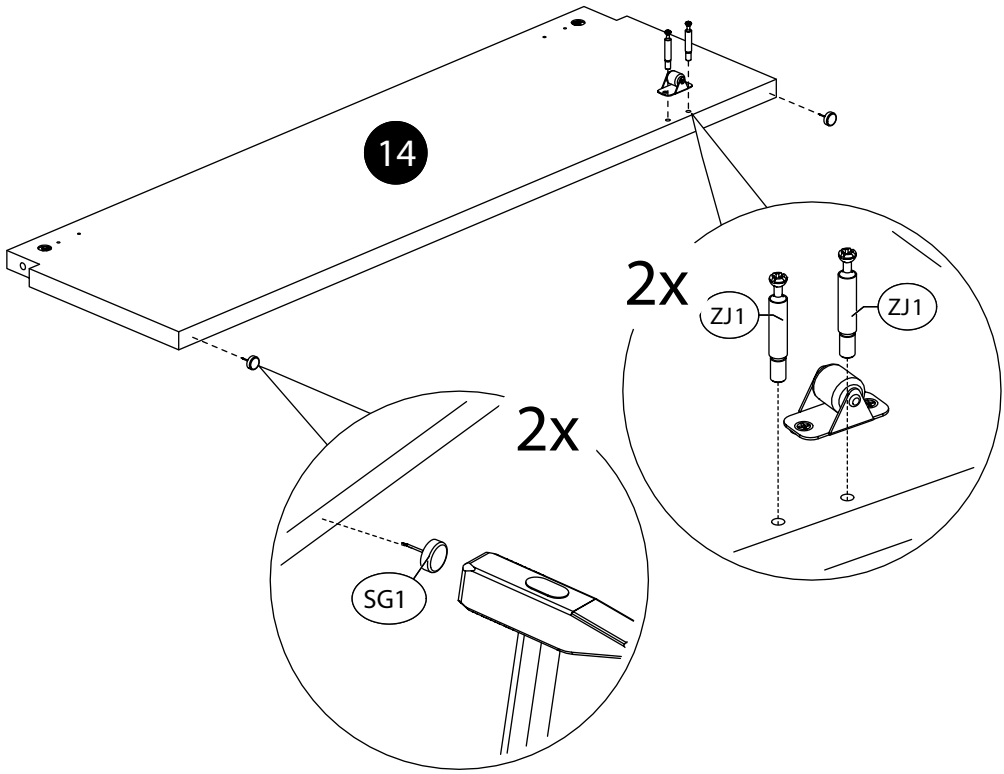

7.

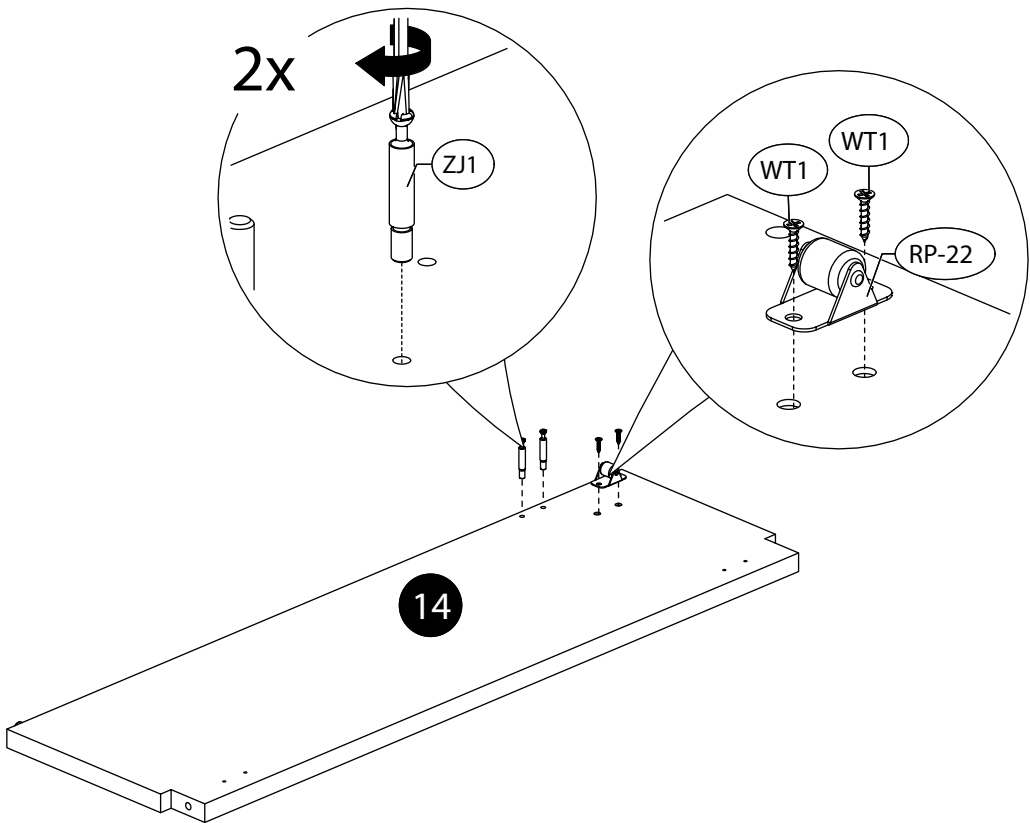
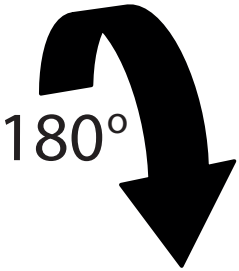



8.

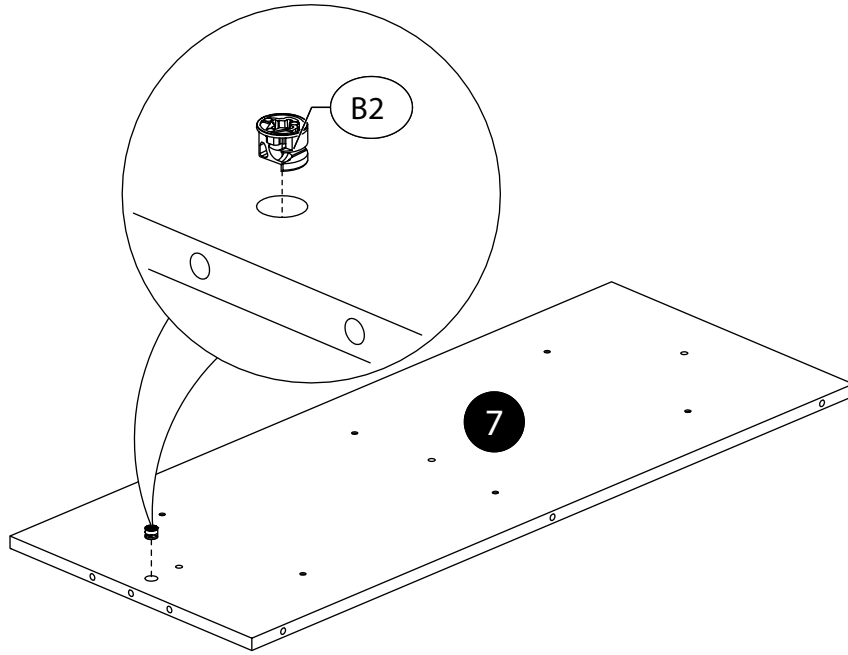

9.

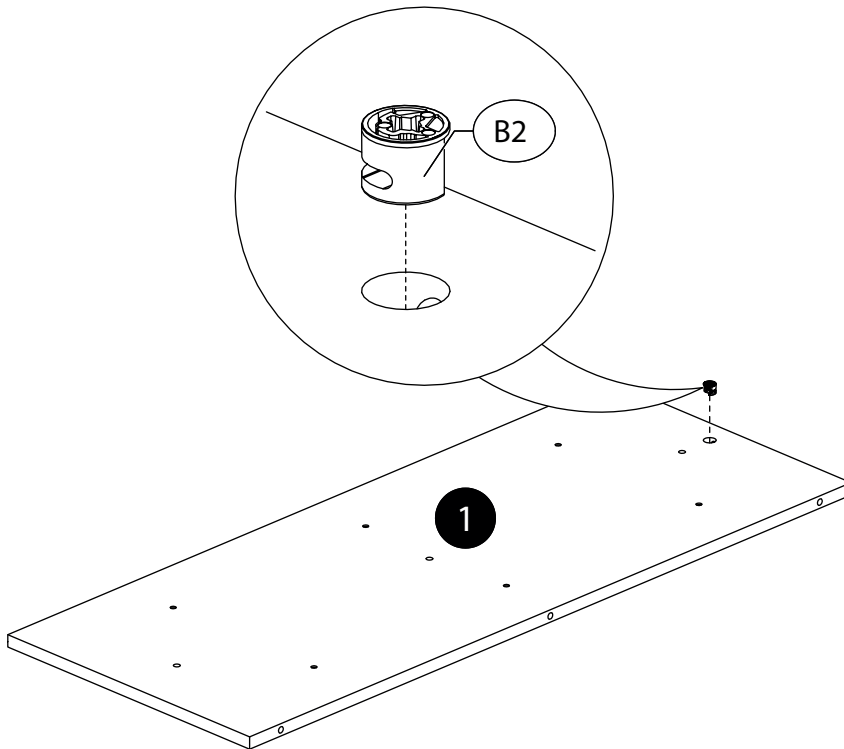

10.

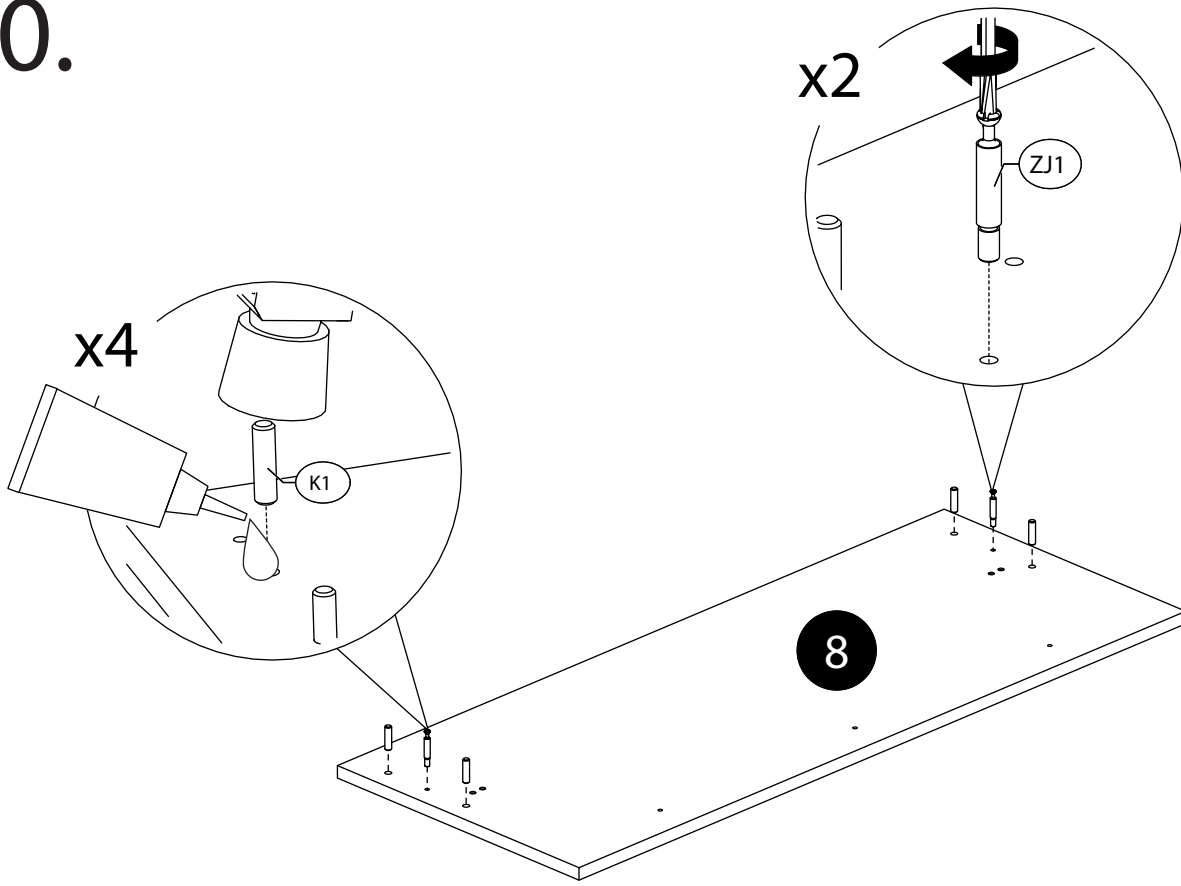

11.

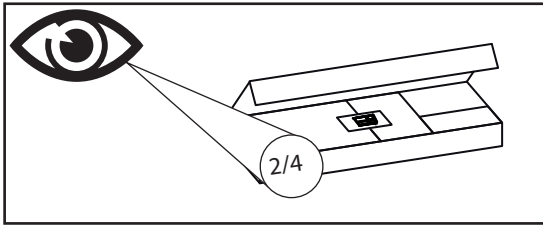

12.

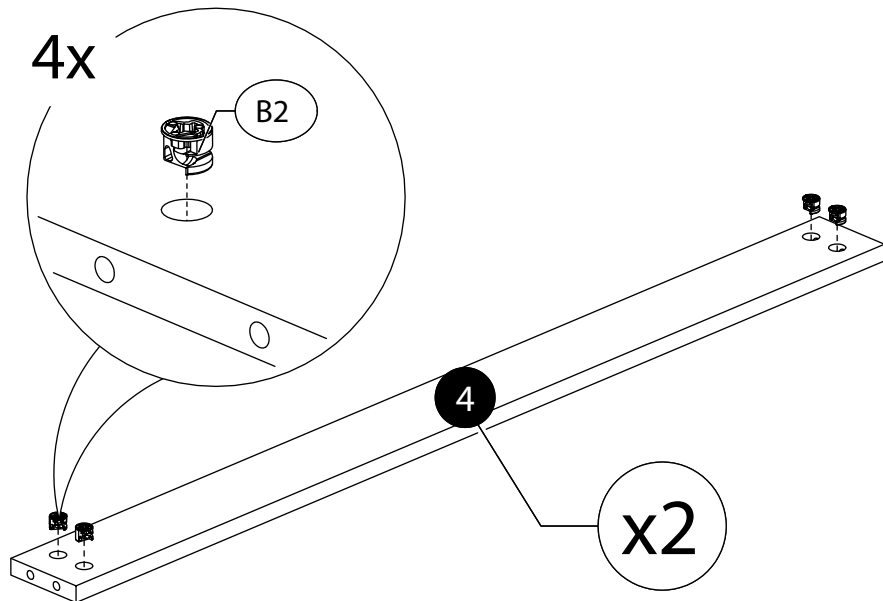

13.

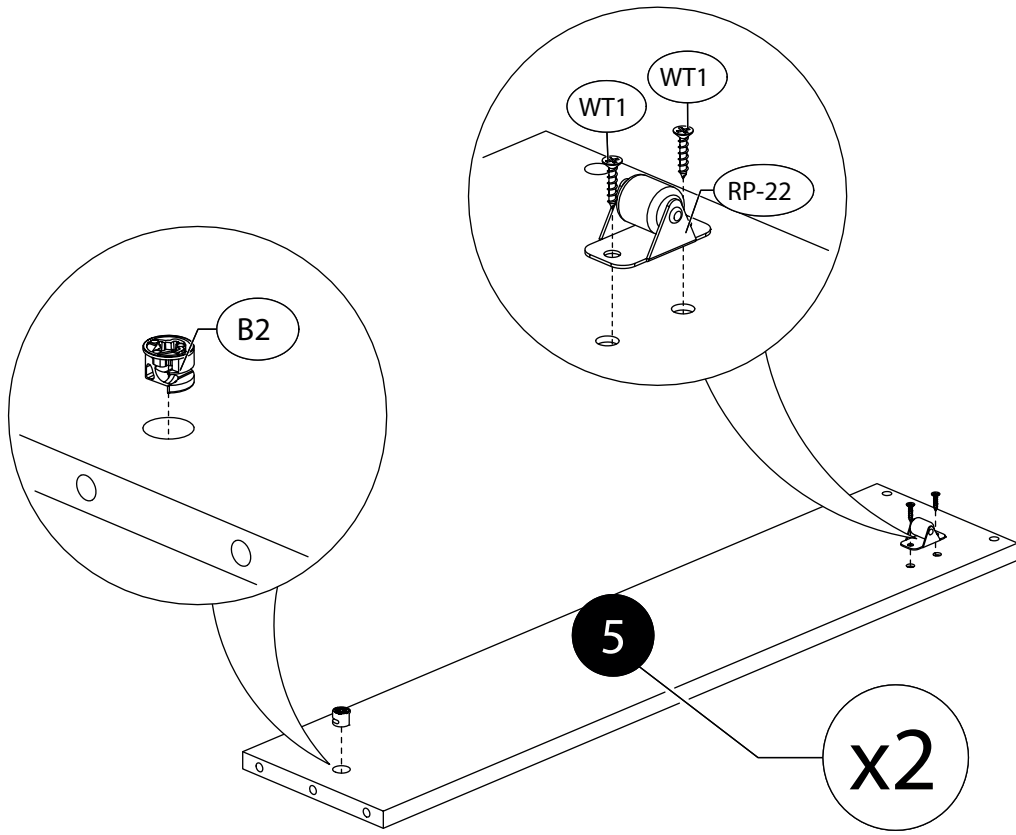

14.

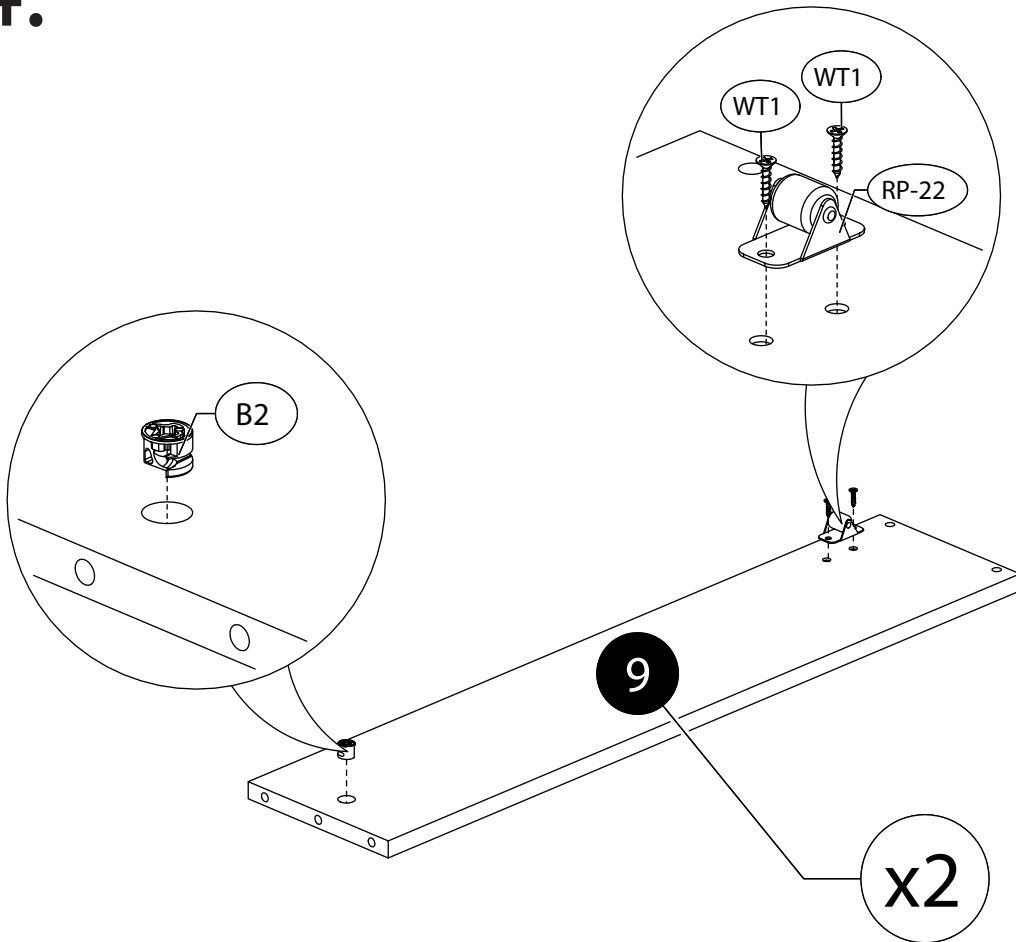

# 15.

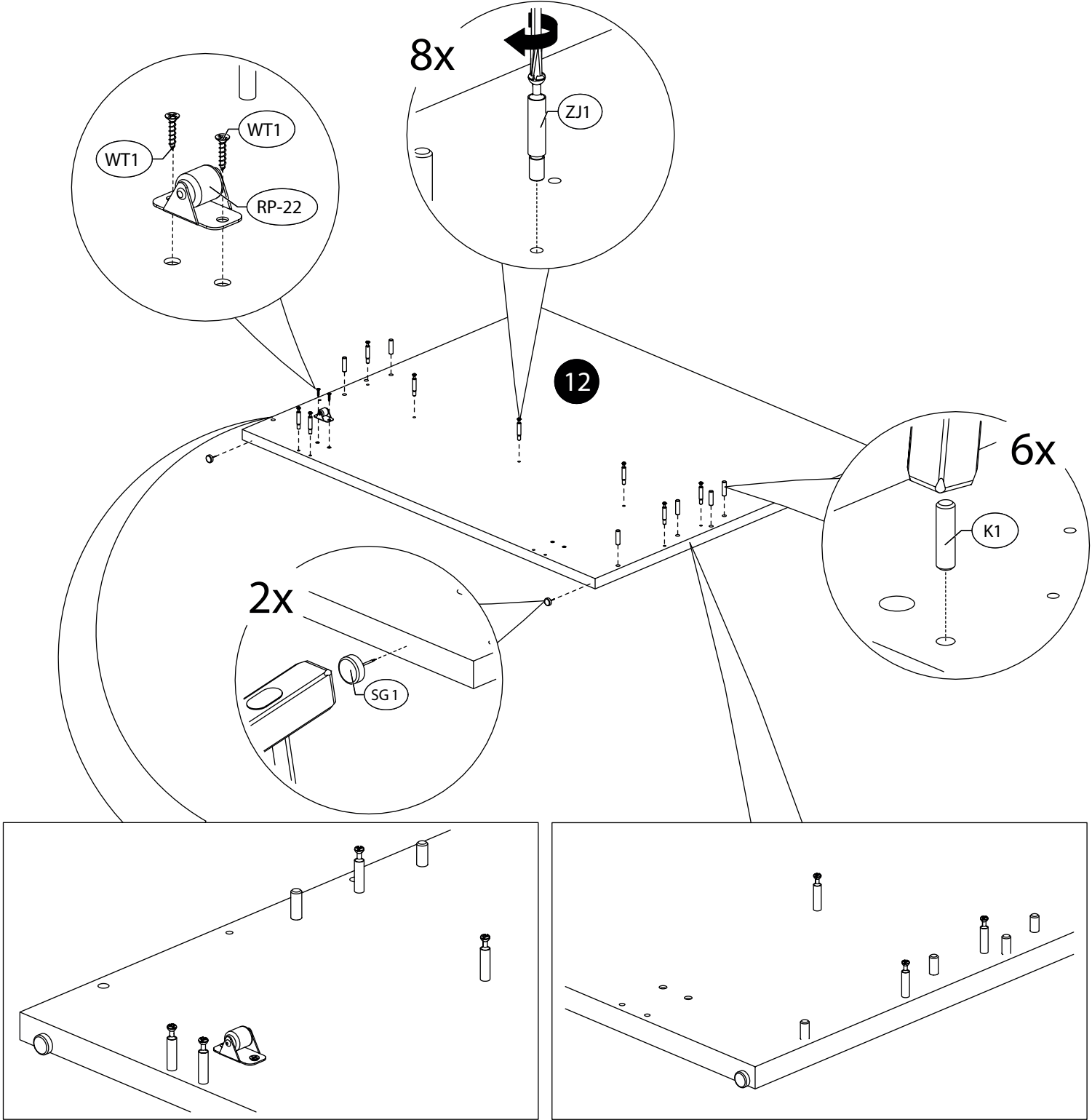

16.

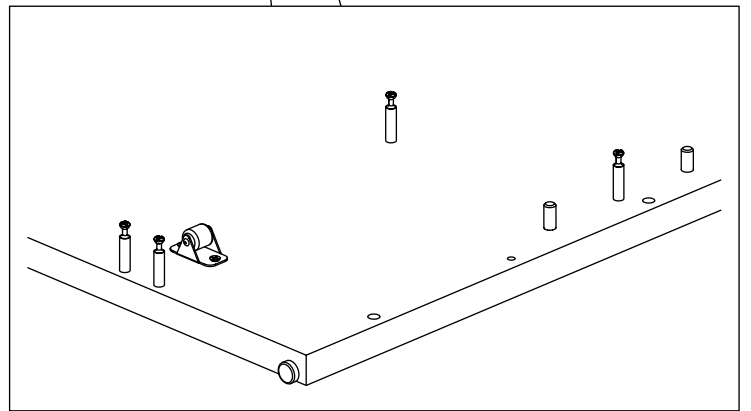
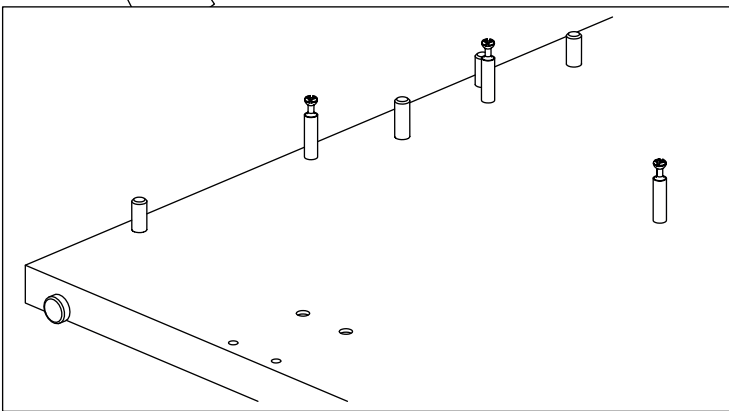
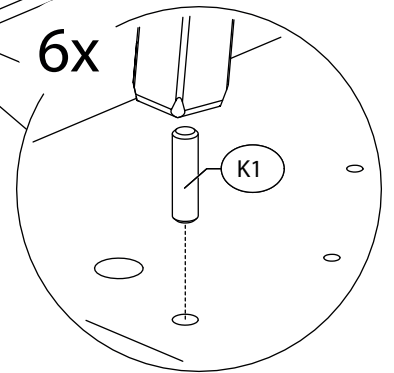
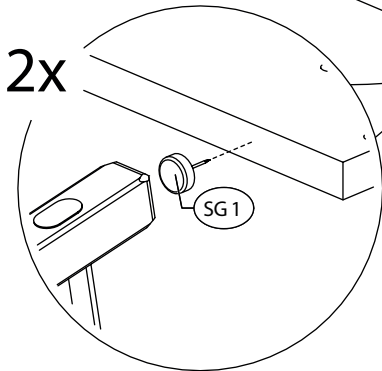
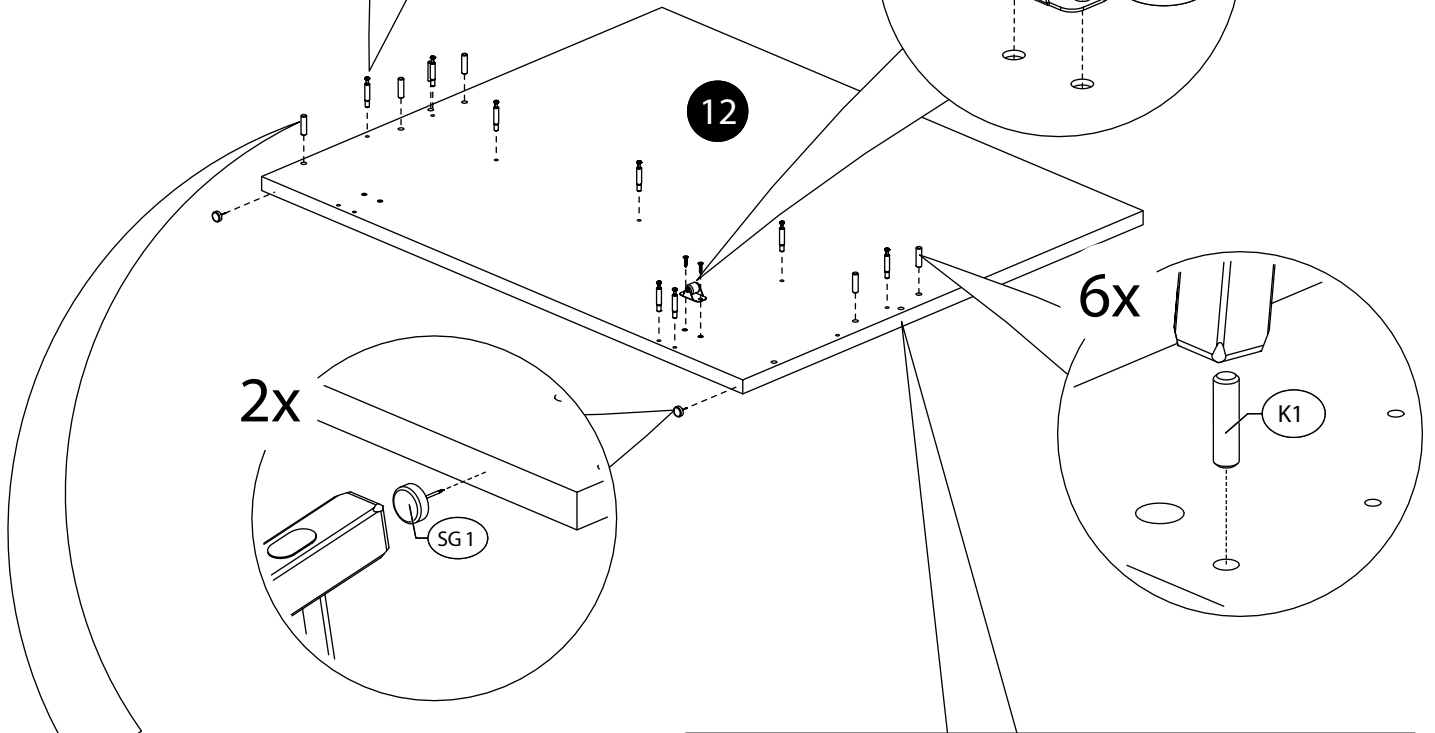
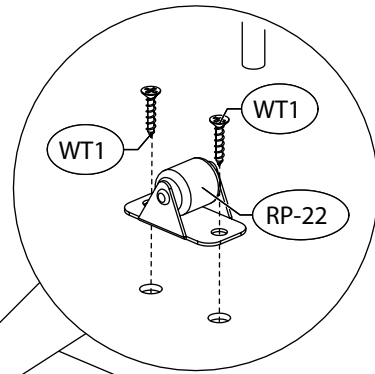
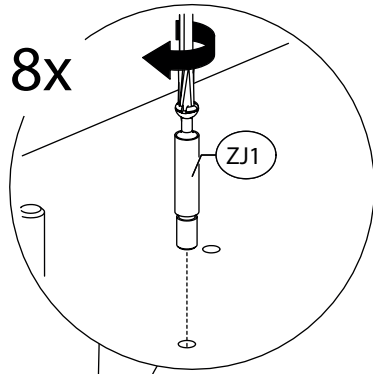
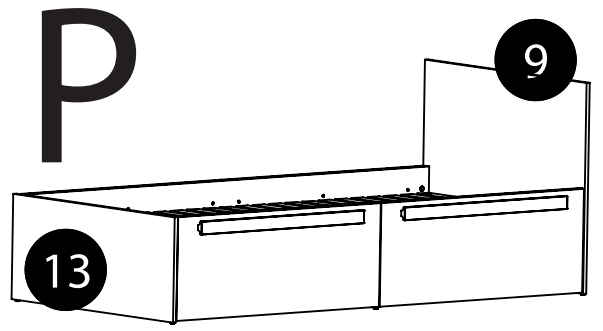

# 17.

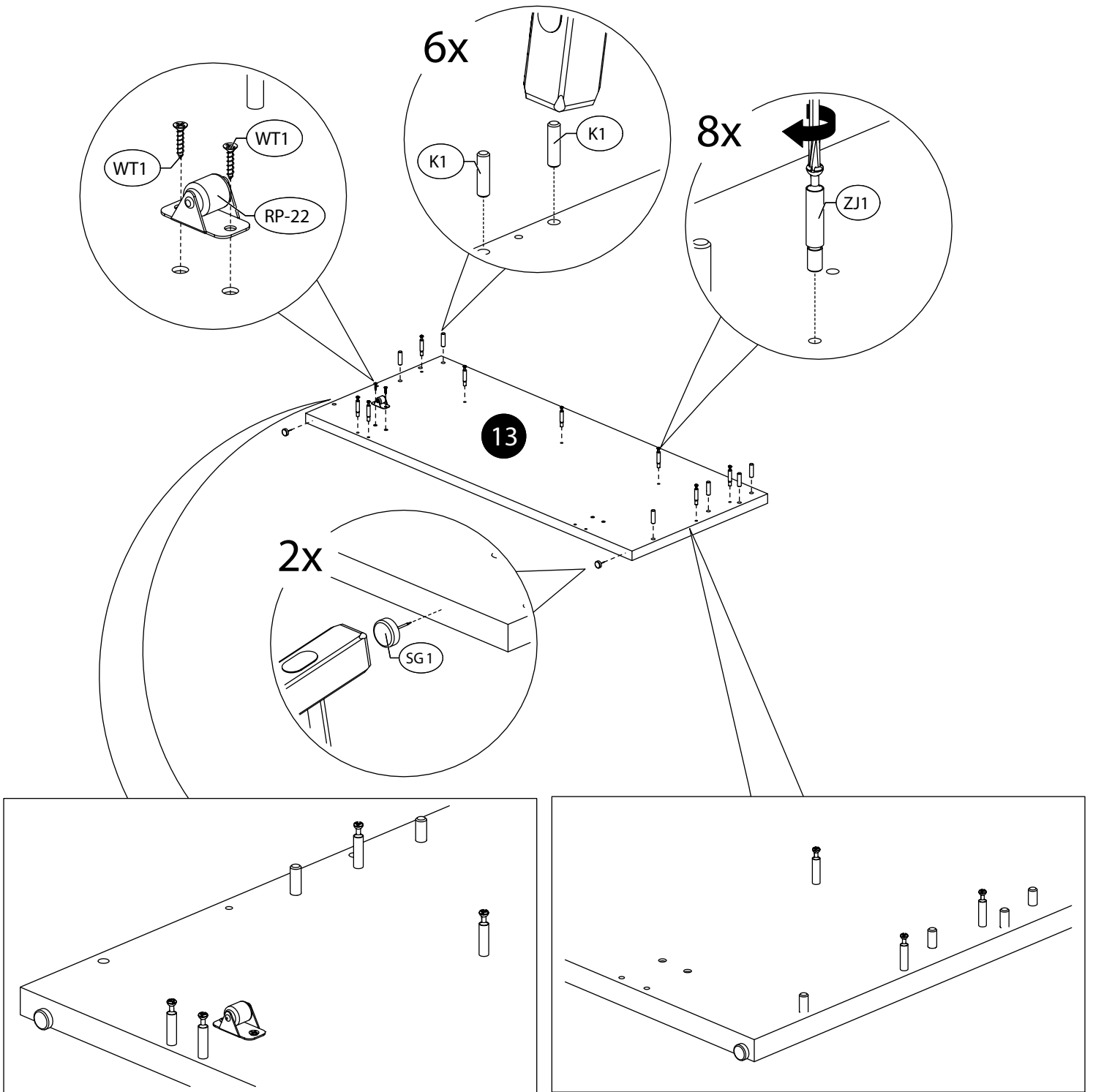

18.

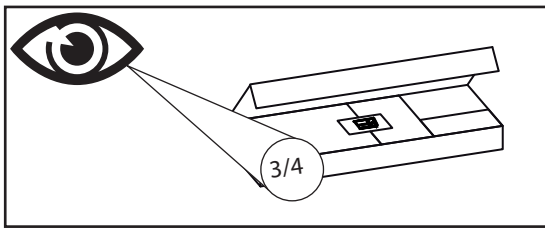

19.

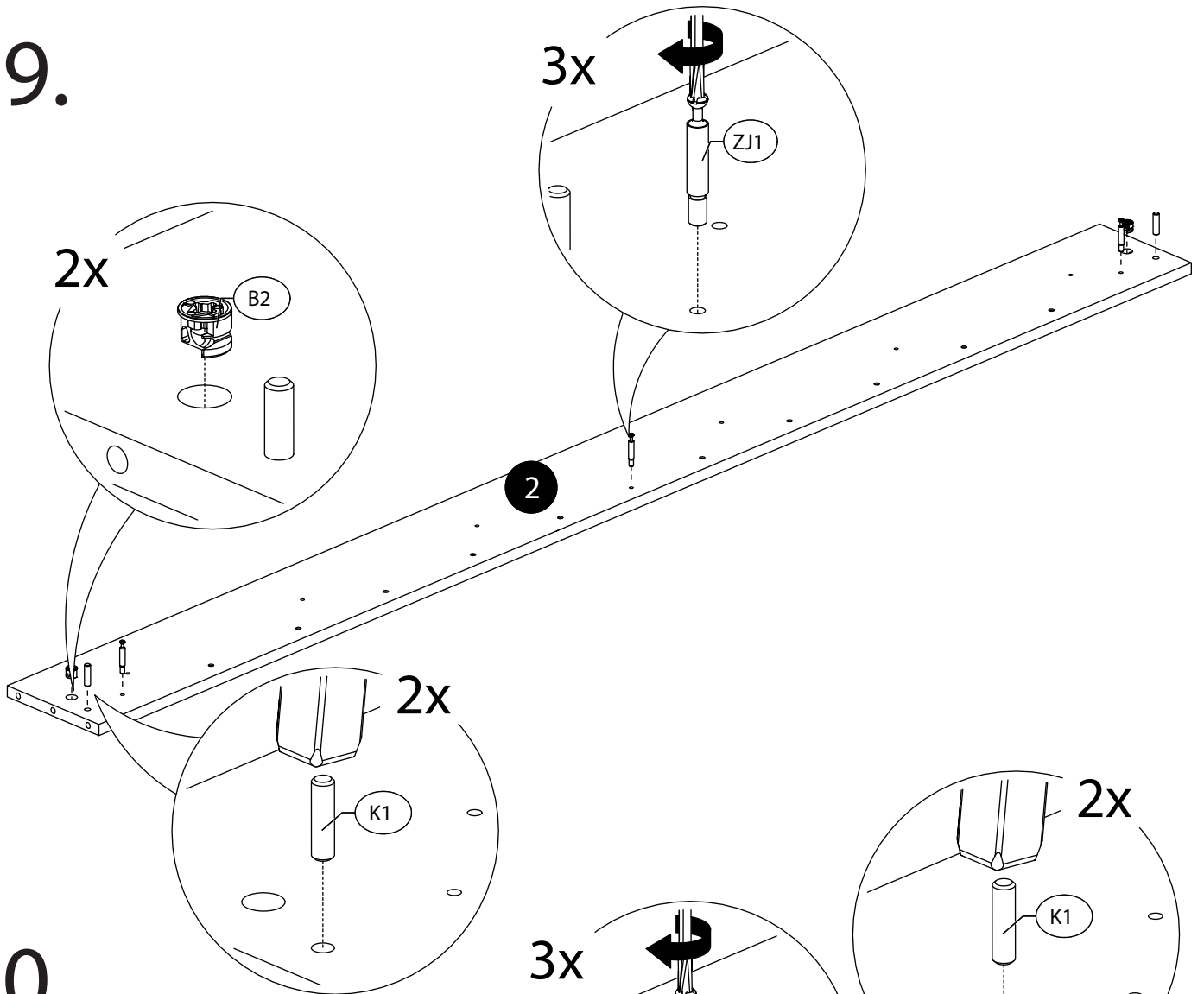

20.

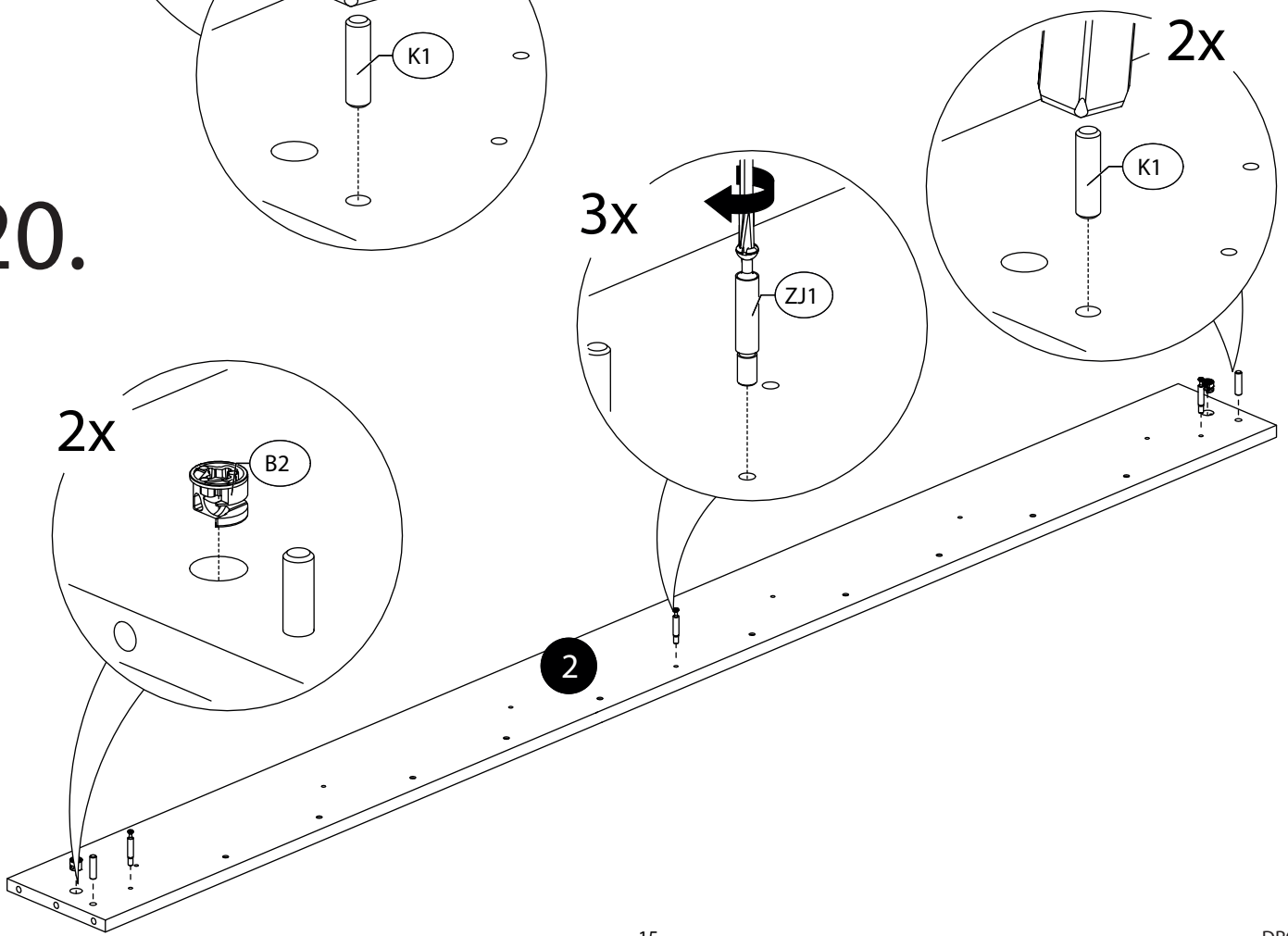

# 21.

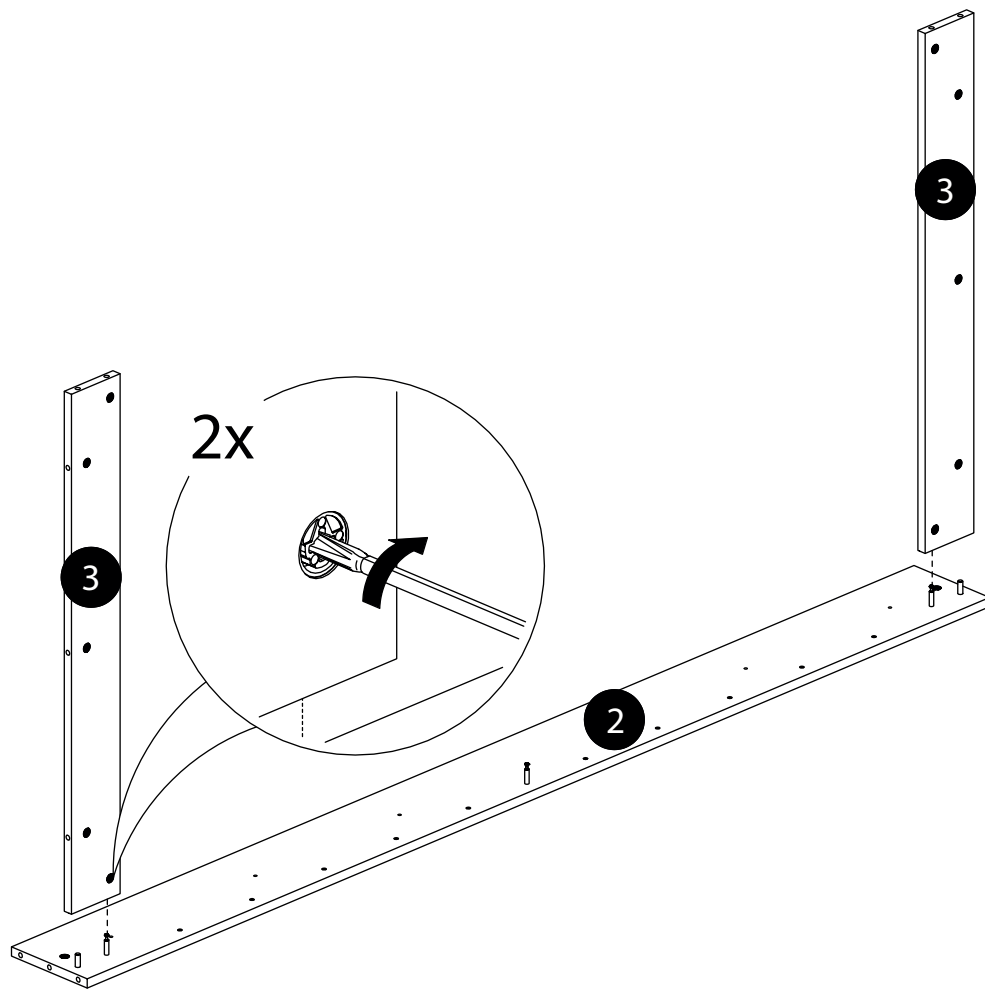

# 22.

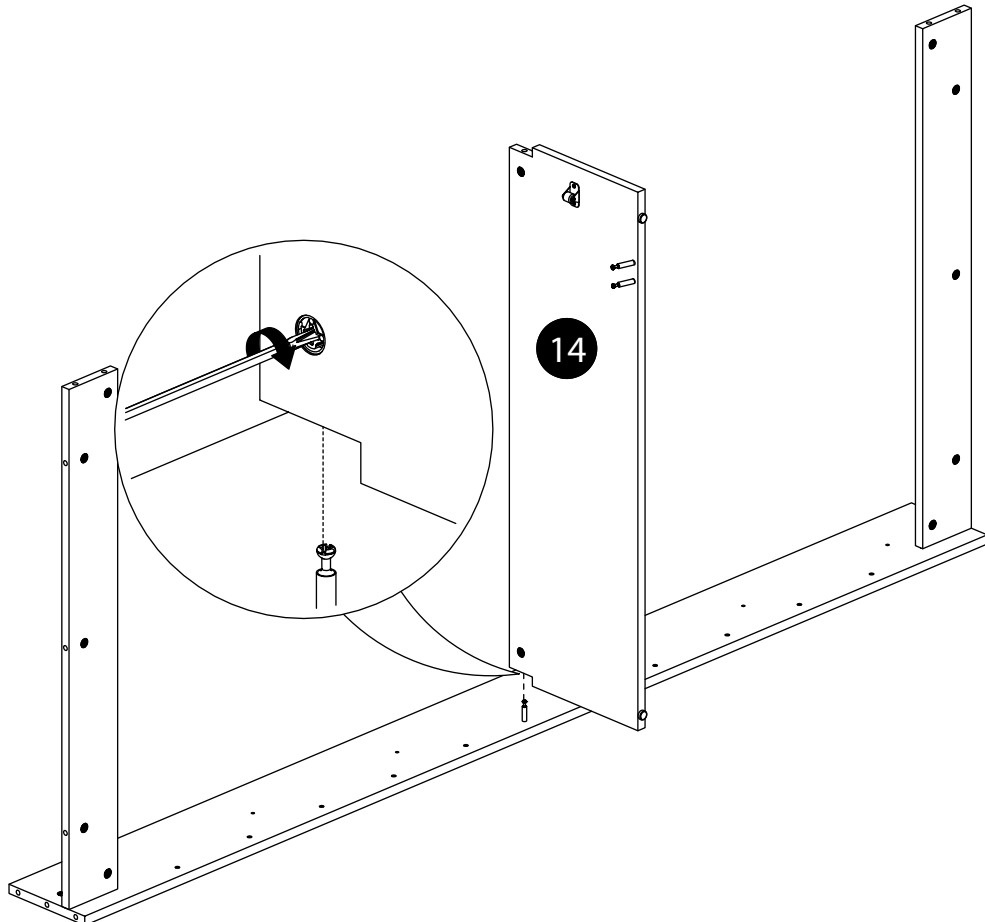



23.

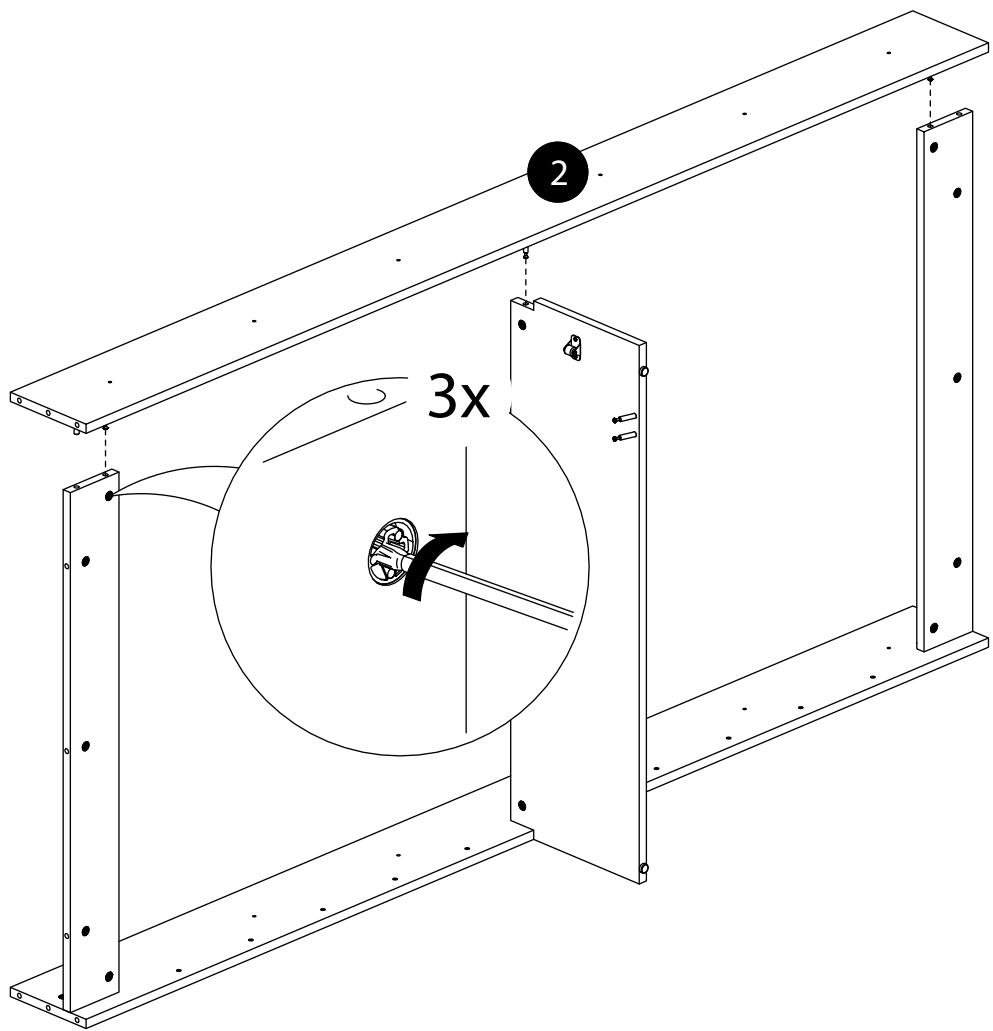

24.

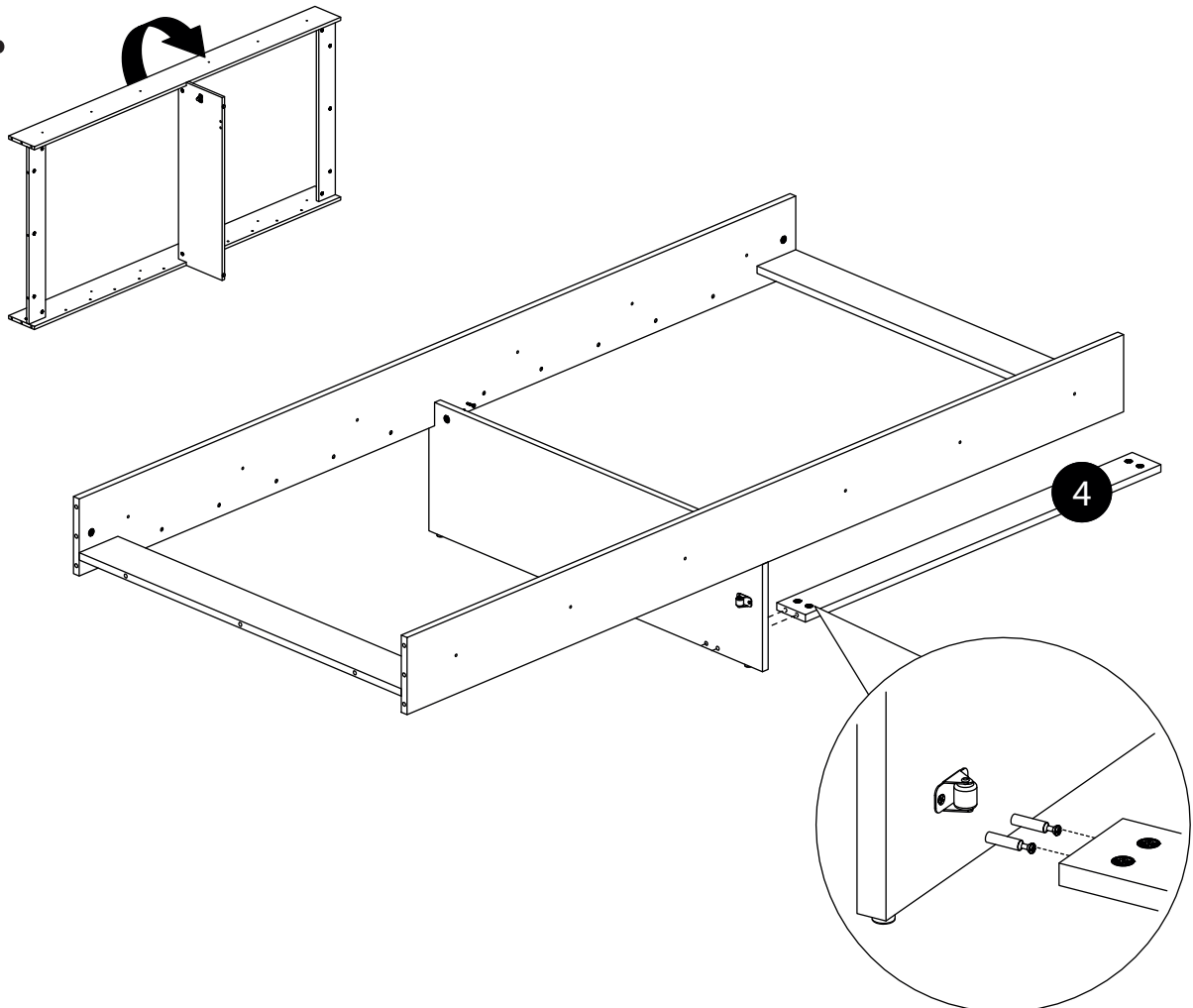

25.

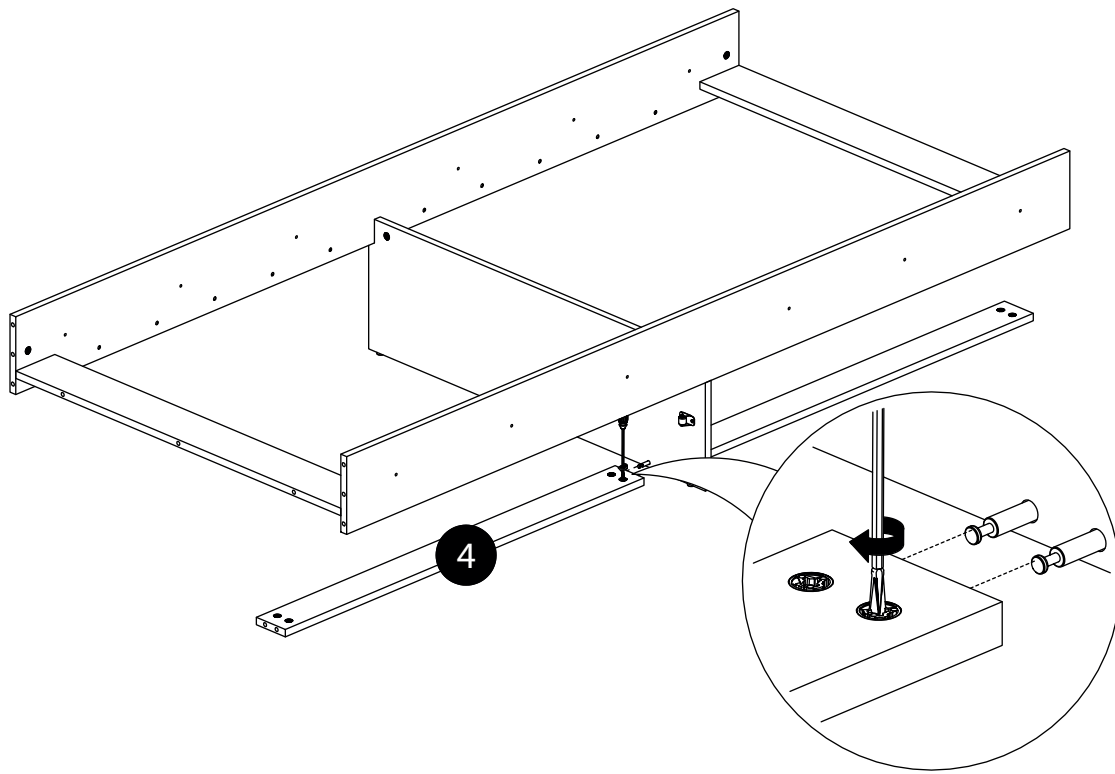

26.

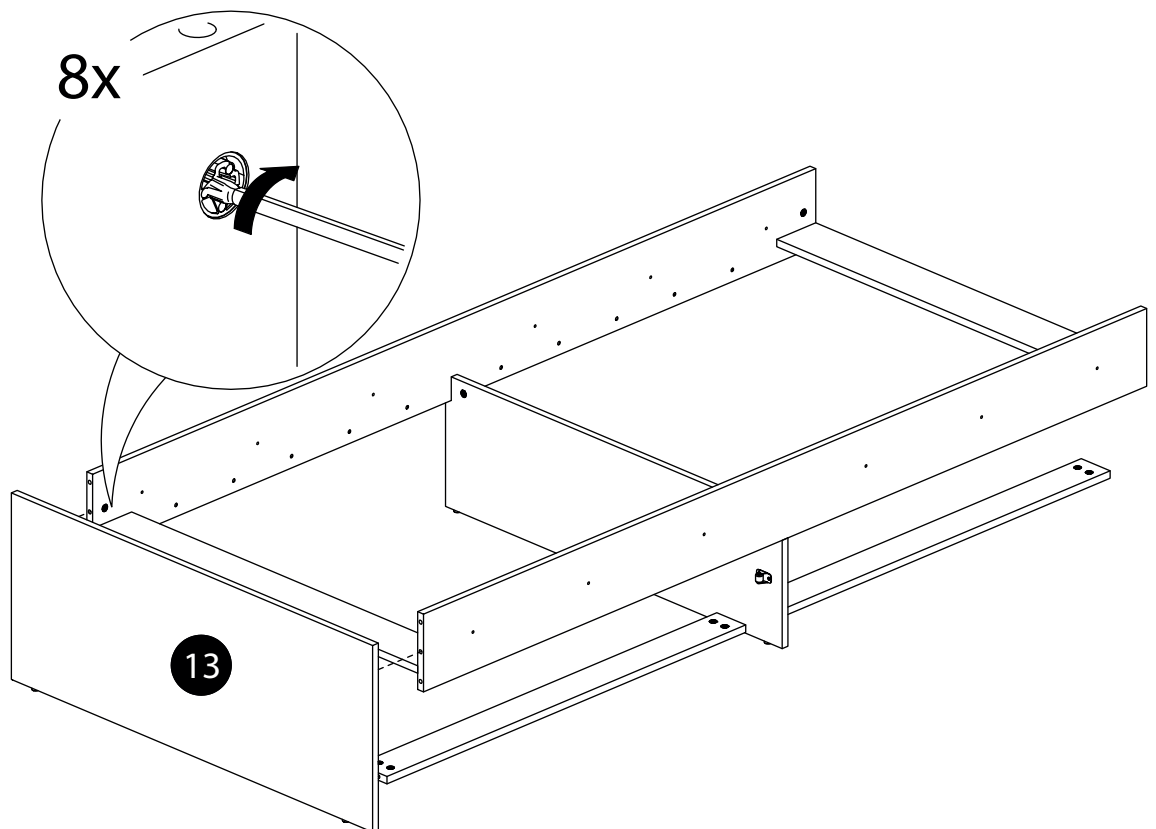

27.

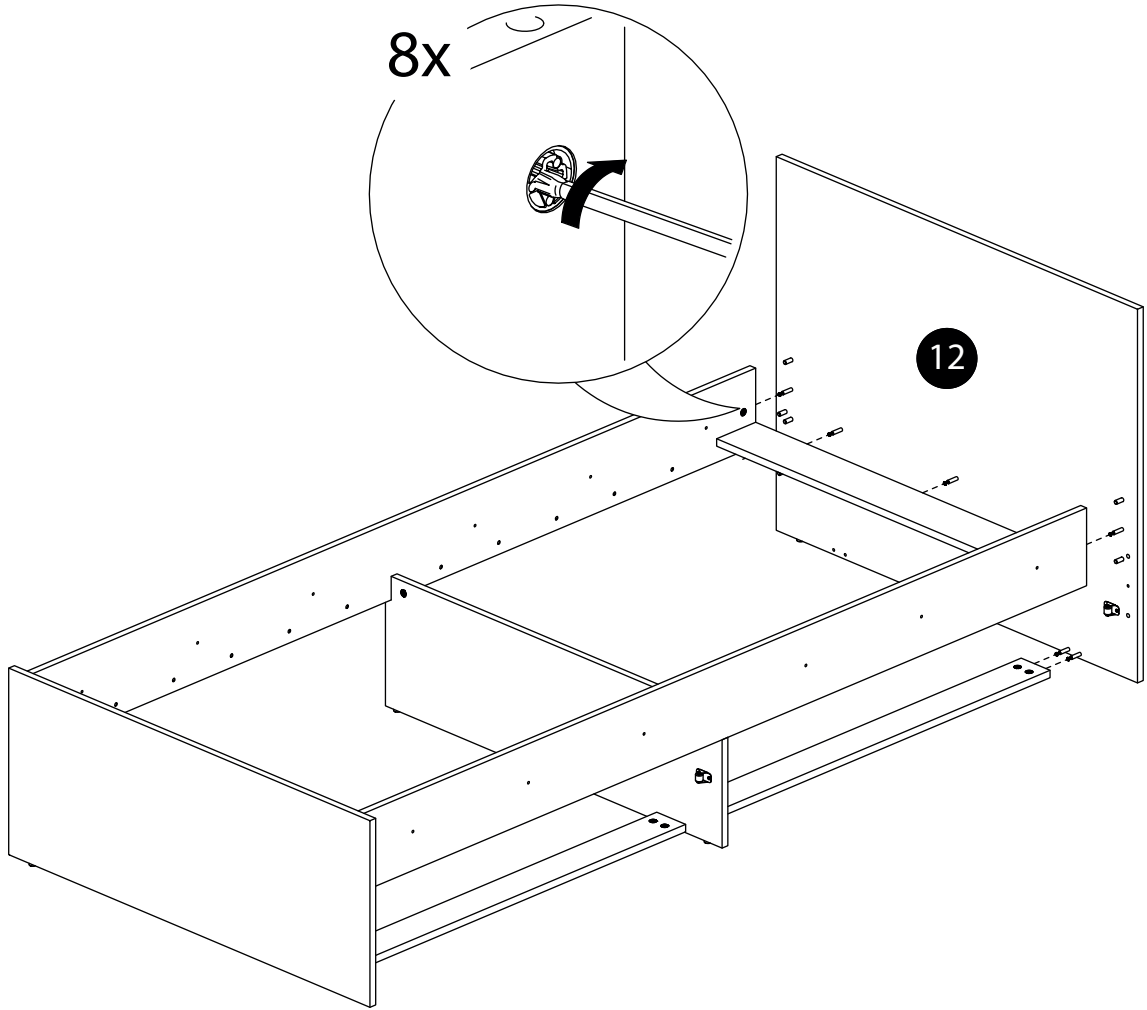

28.

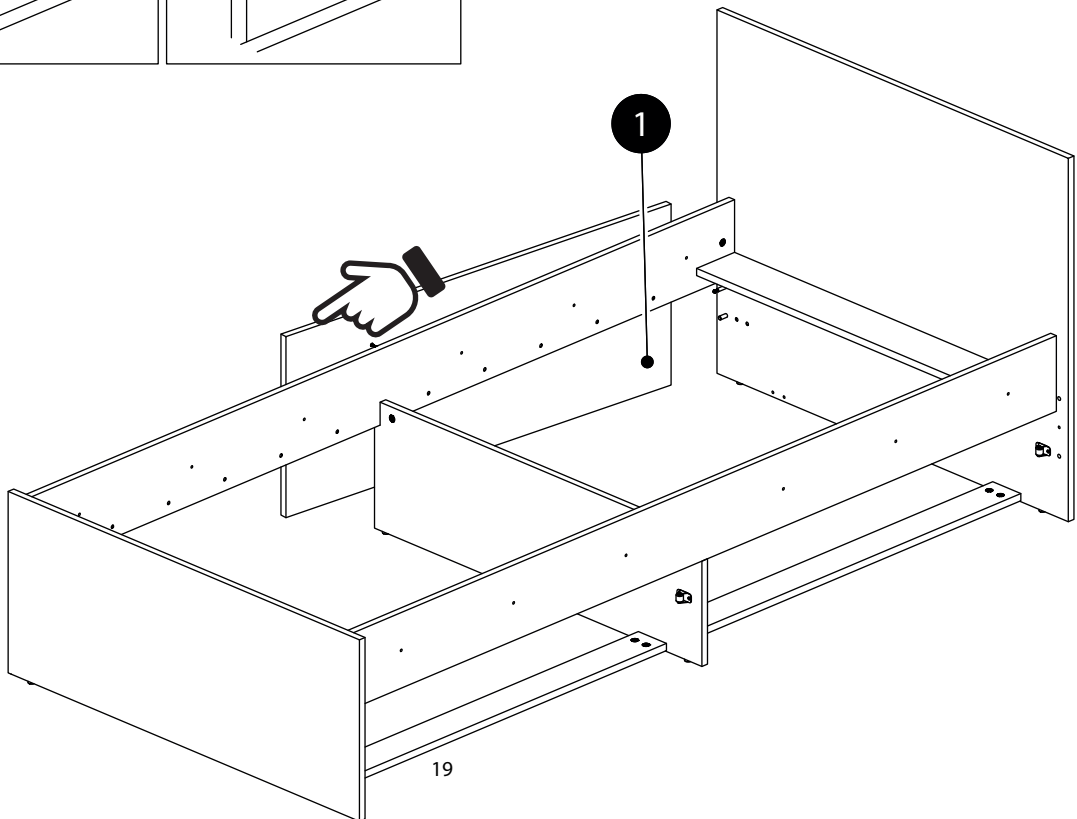
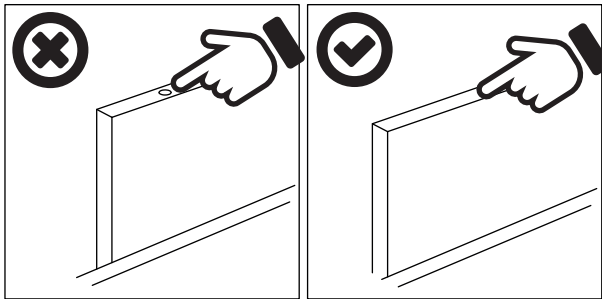

29.

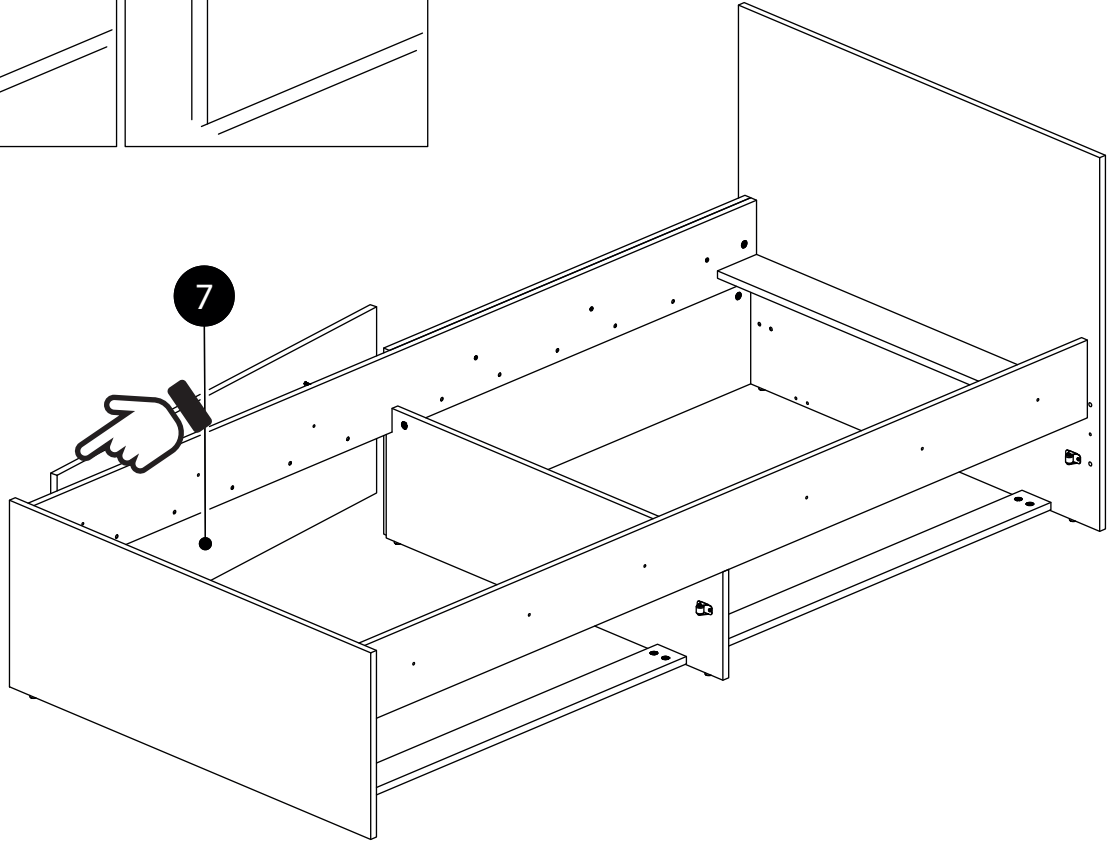
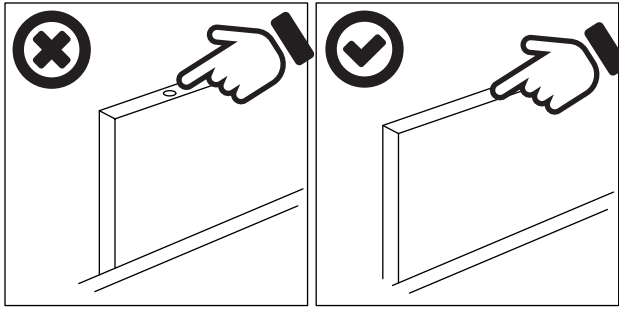

30.

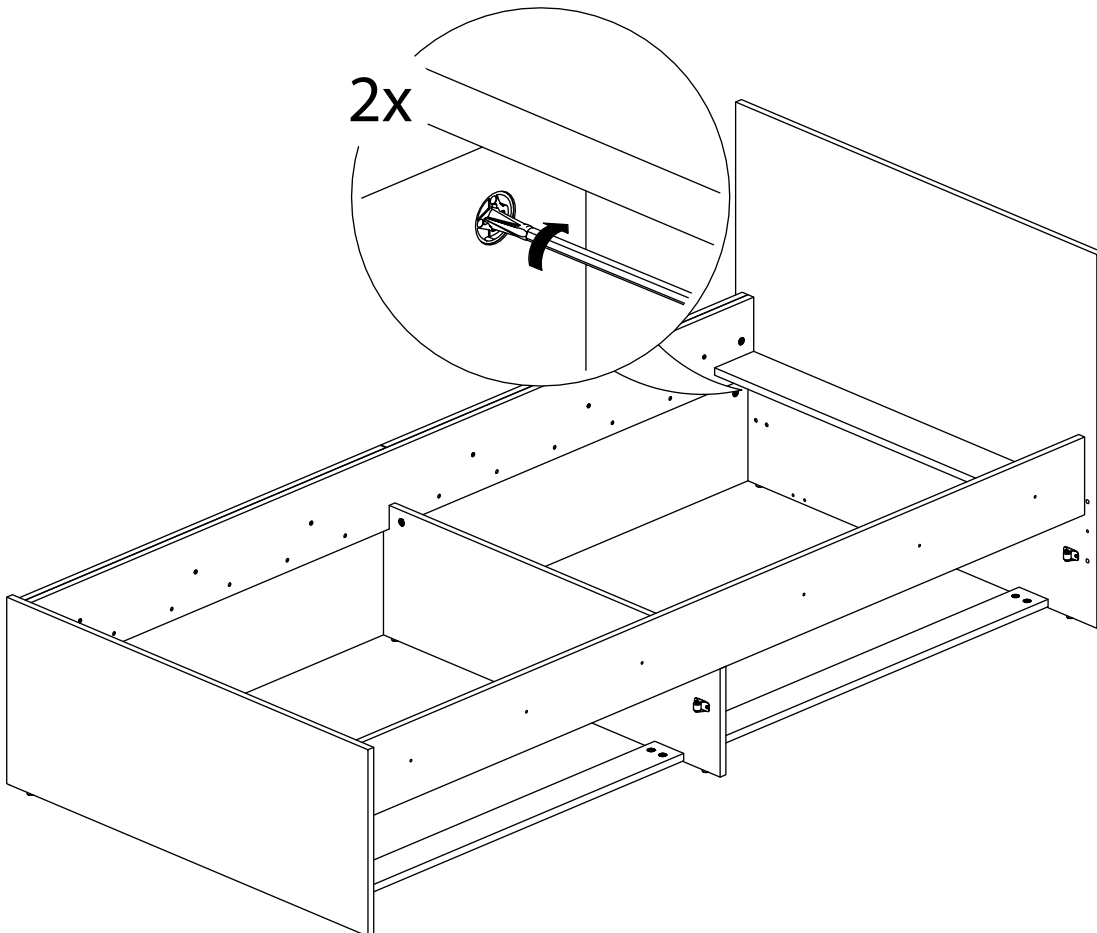

# 31.

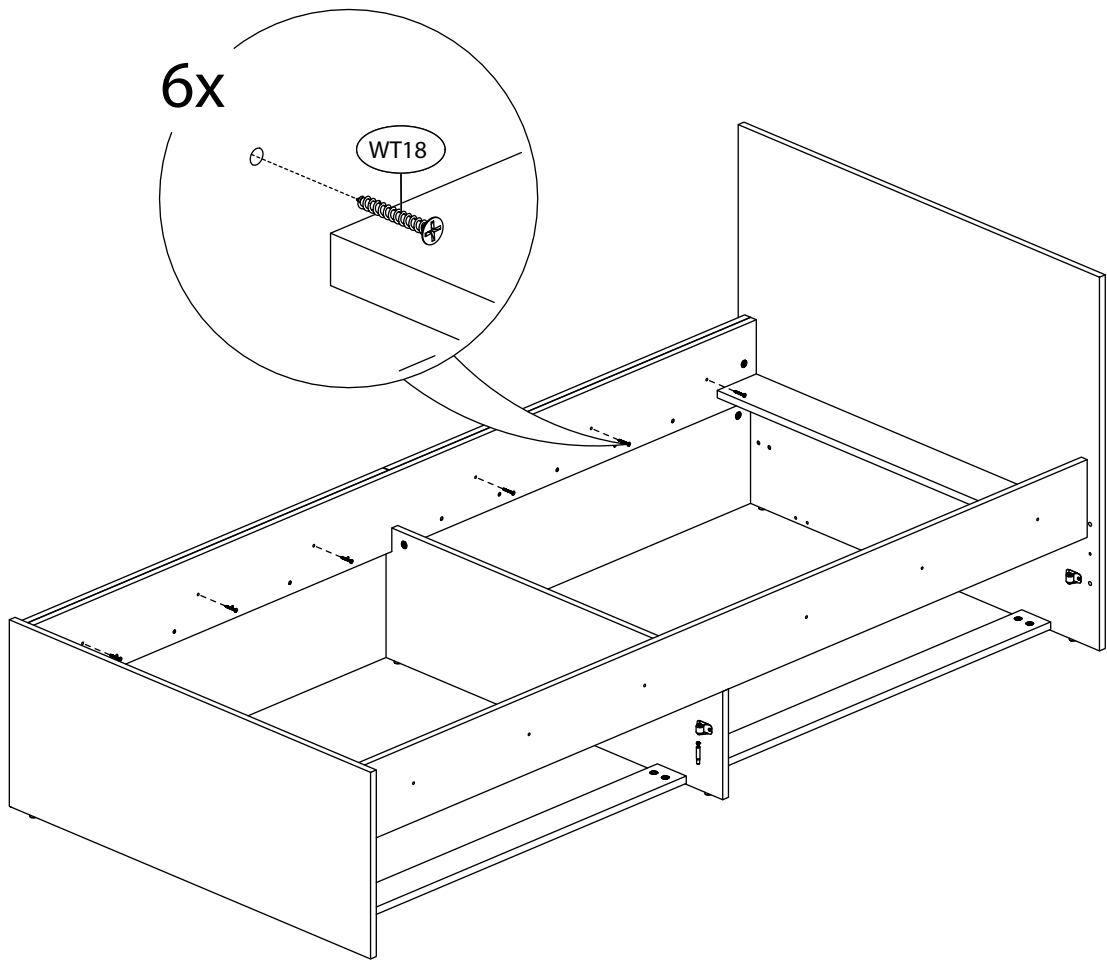

# 32.

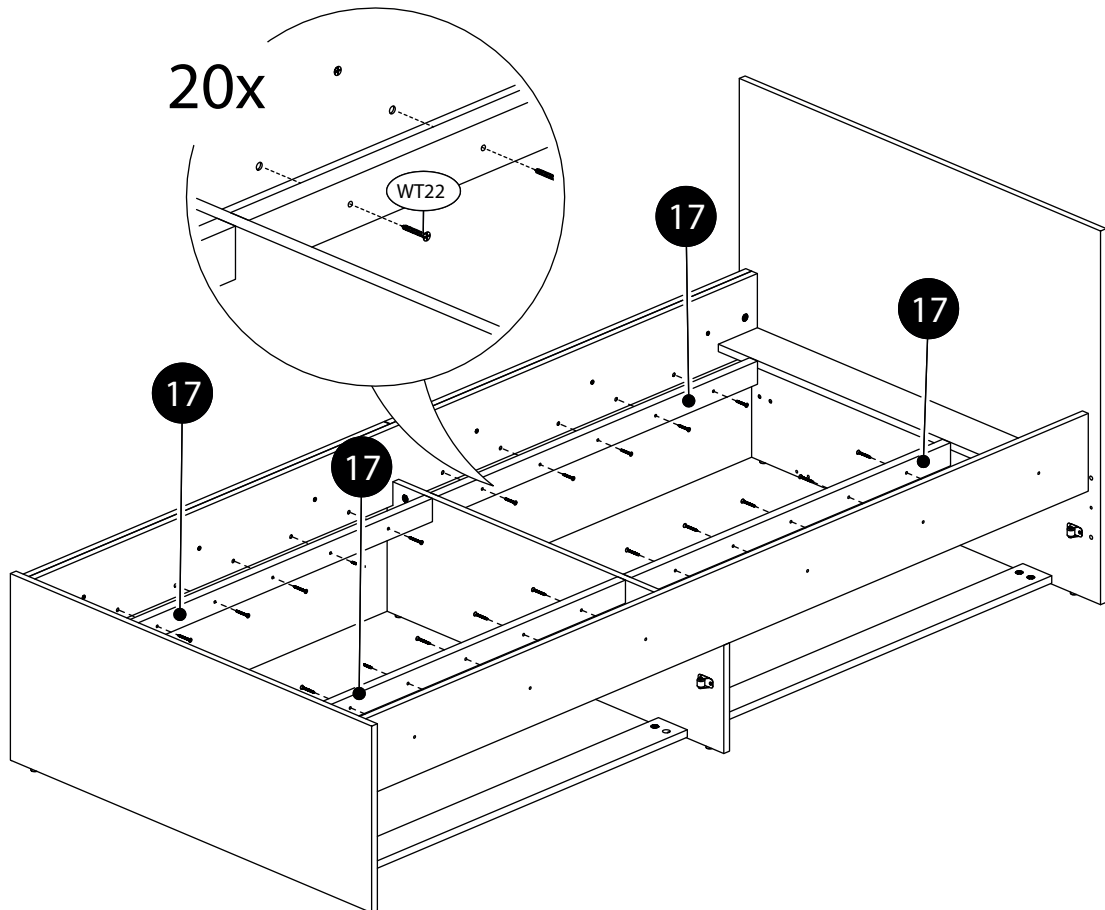

33.

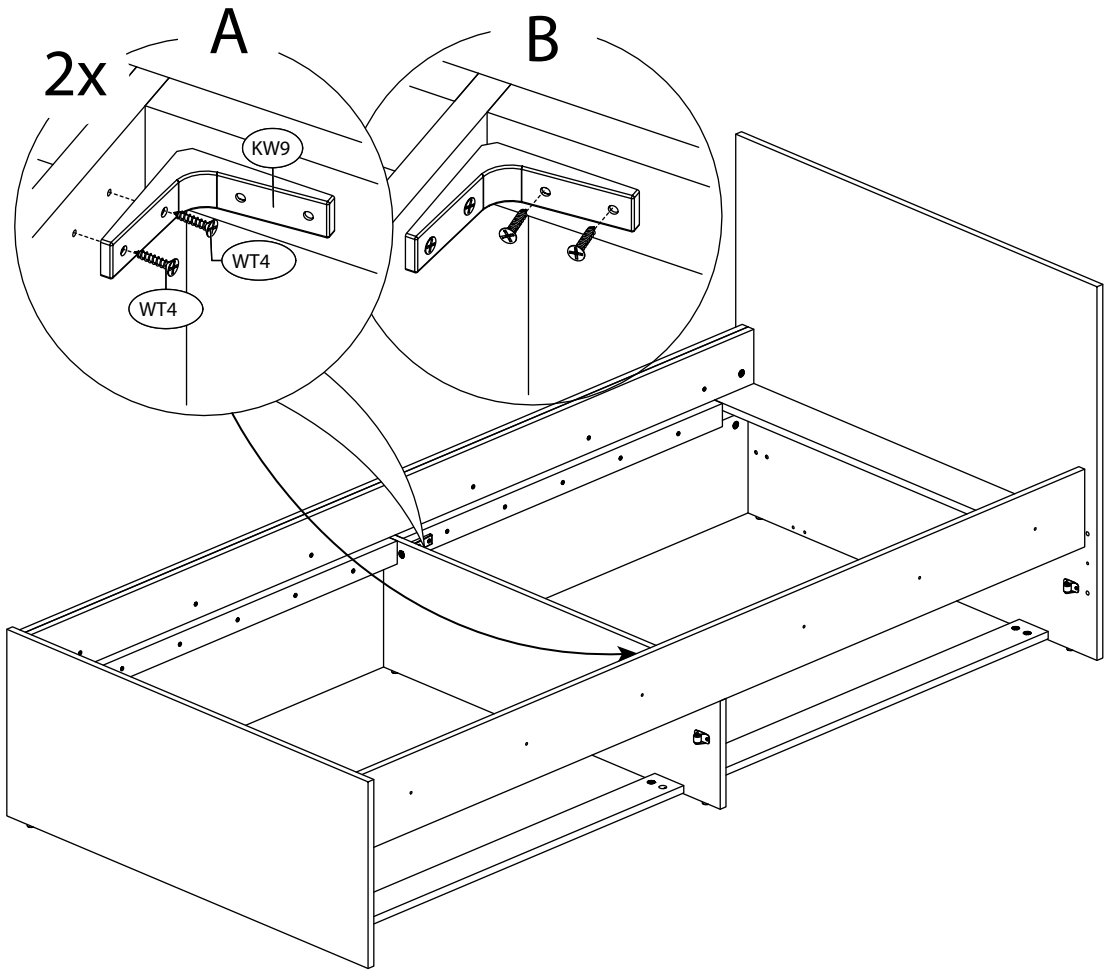

34.

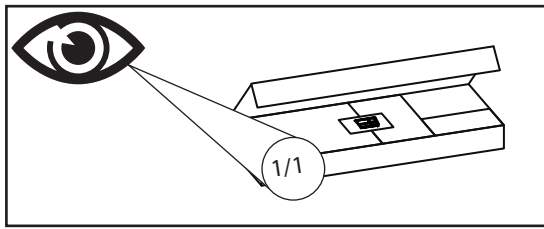

35.

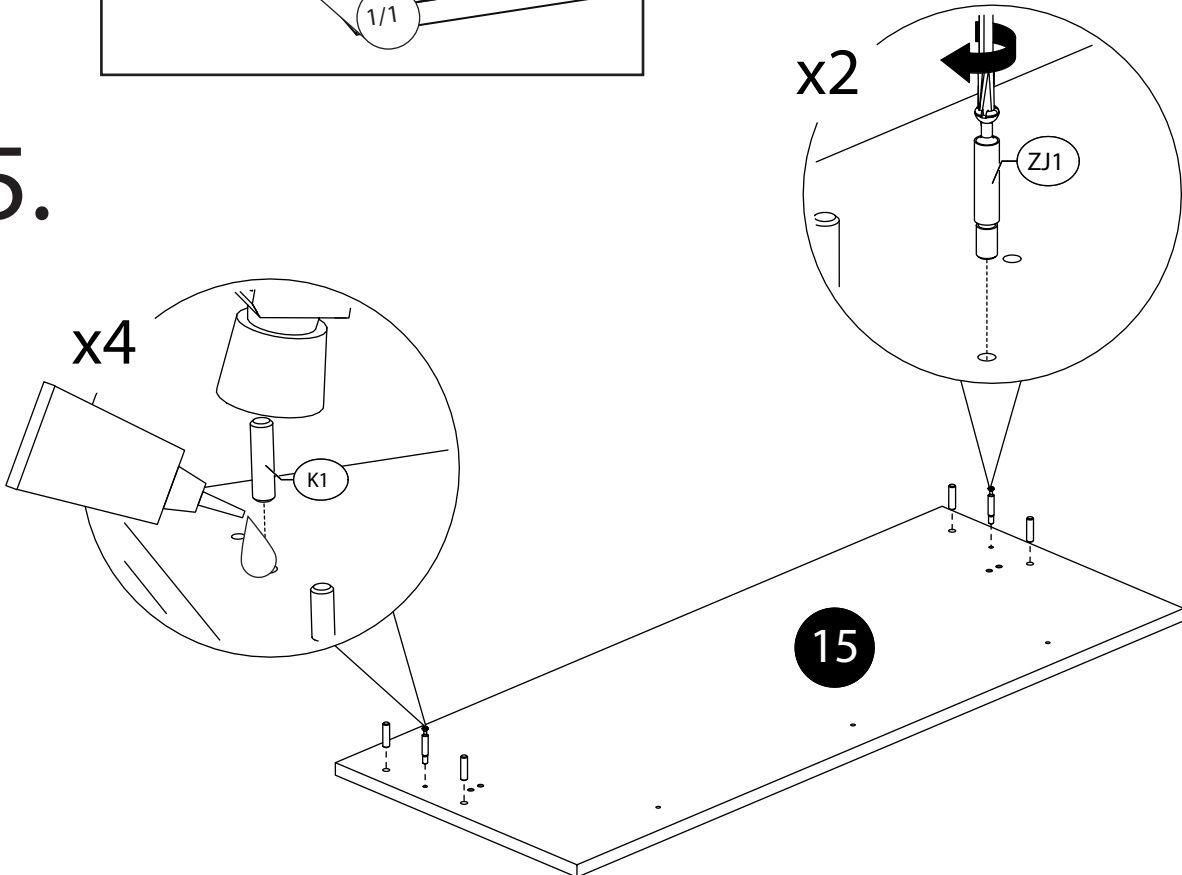

# 36.

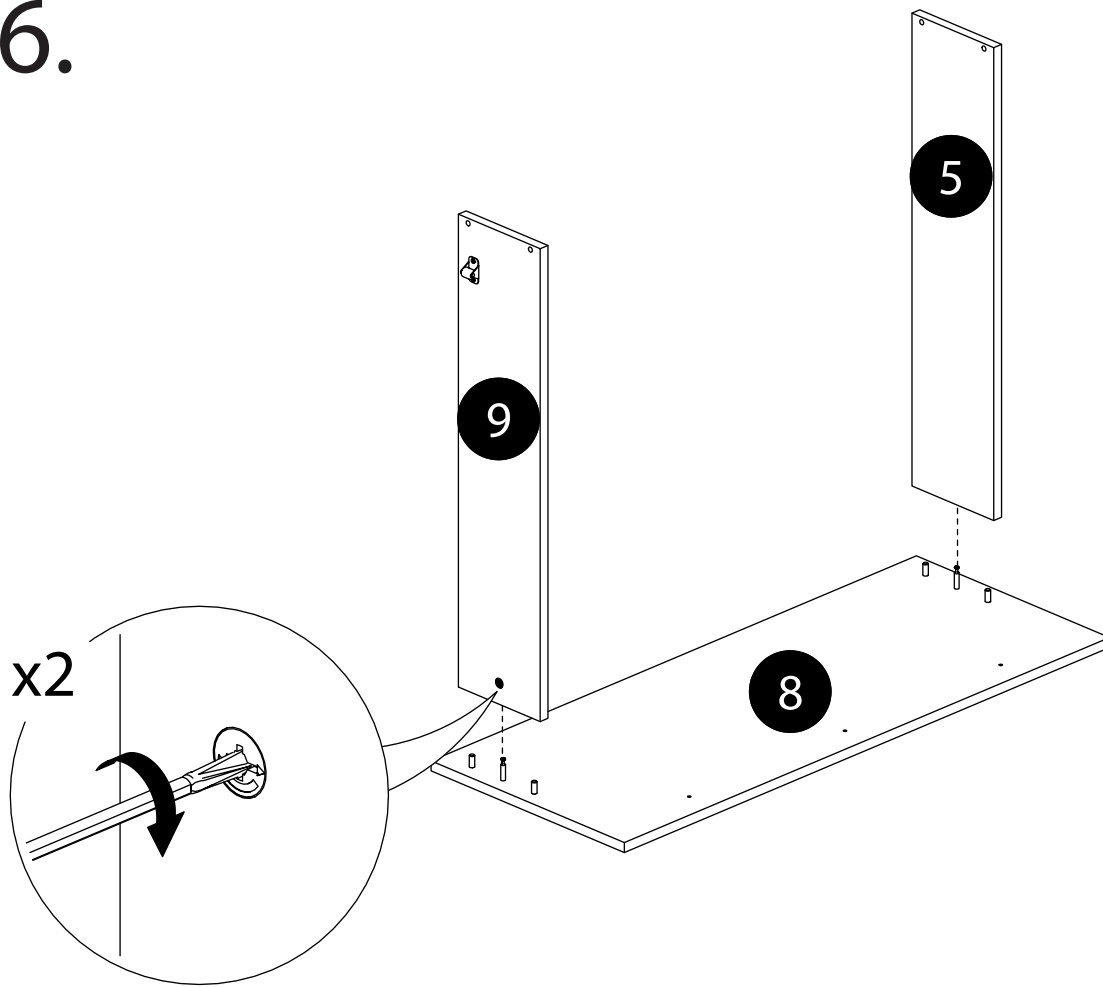

# 37.

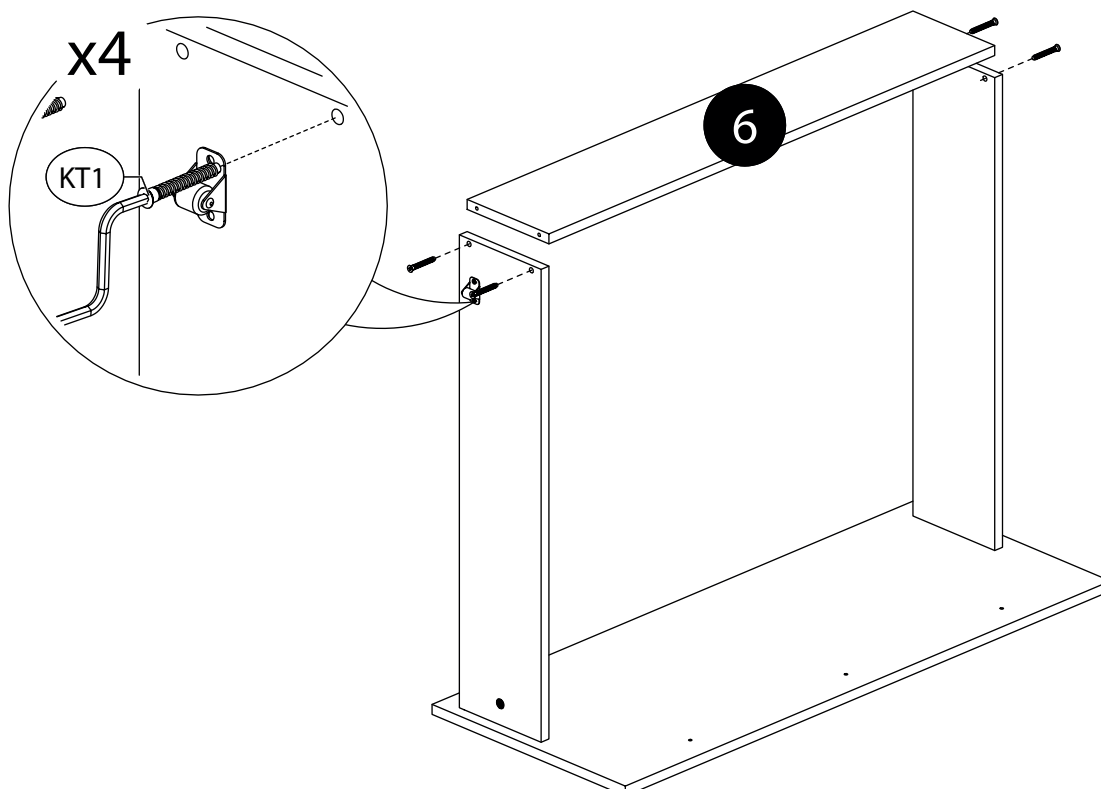

# 38.

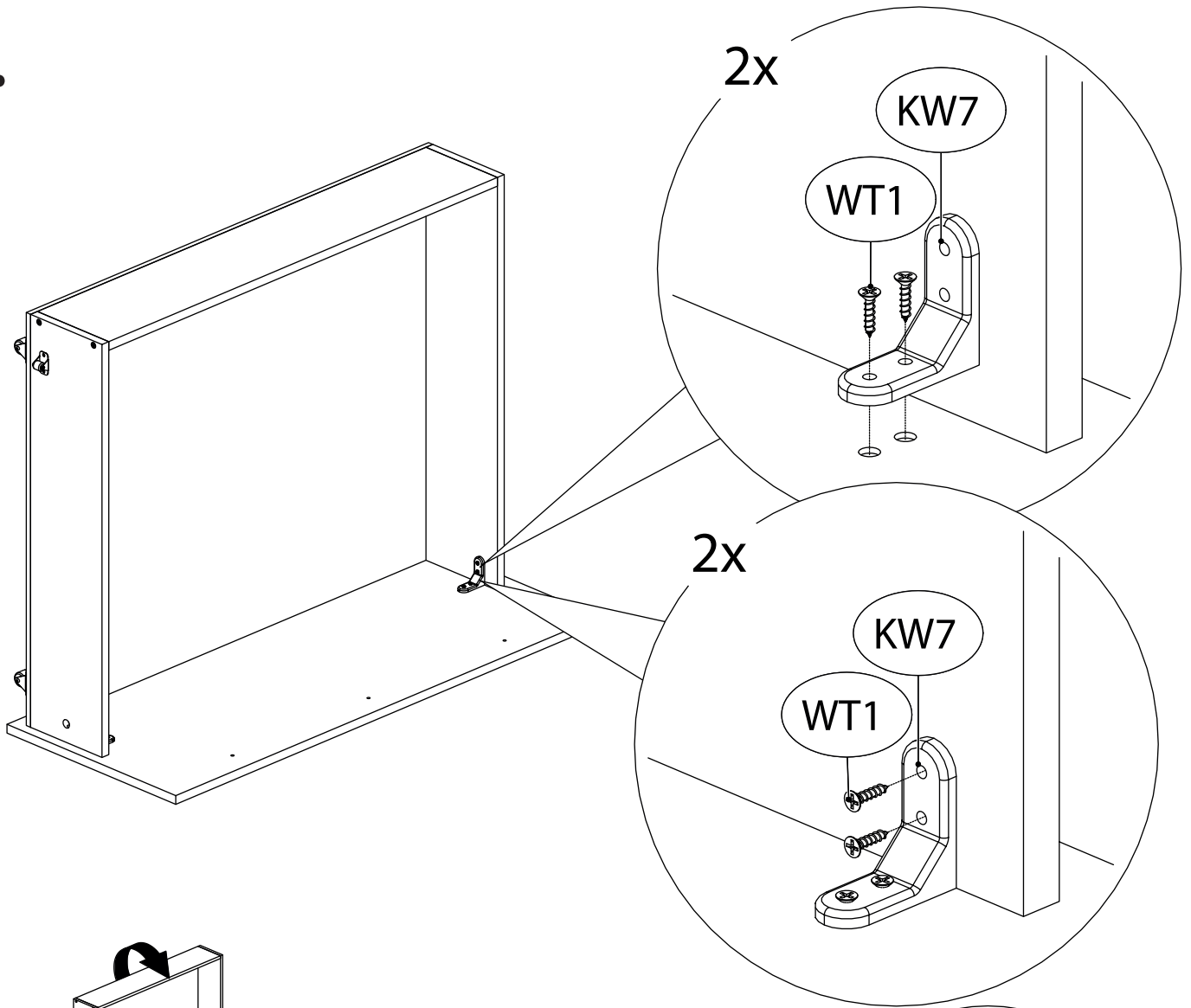

# 39.

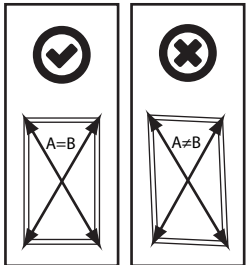
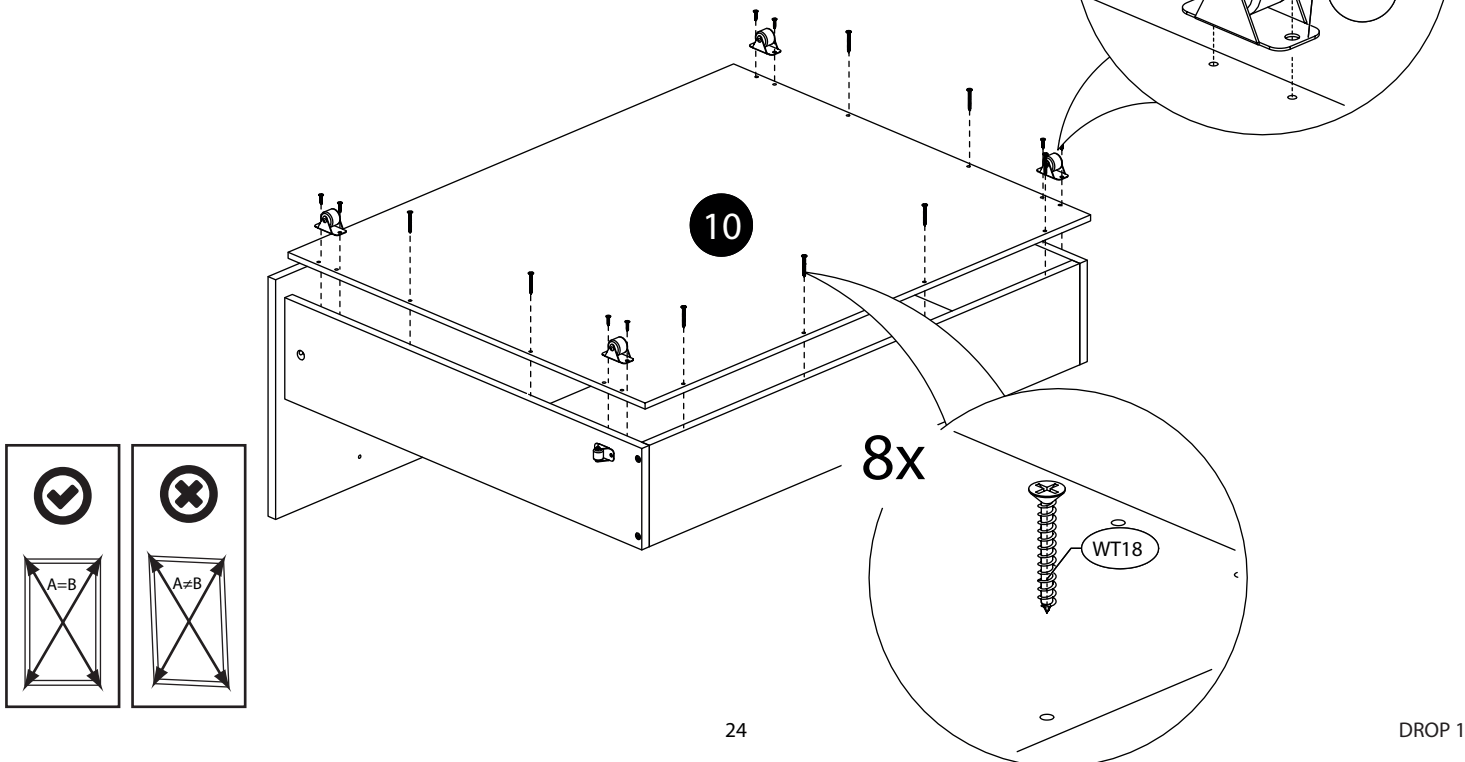
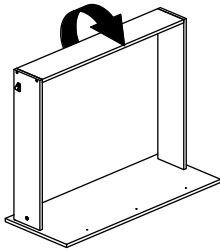



40.

x2

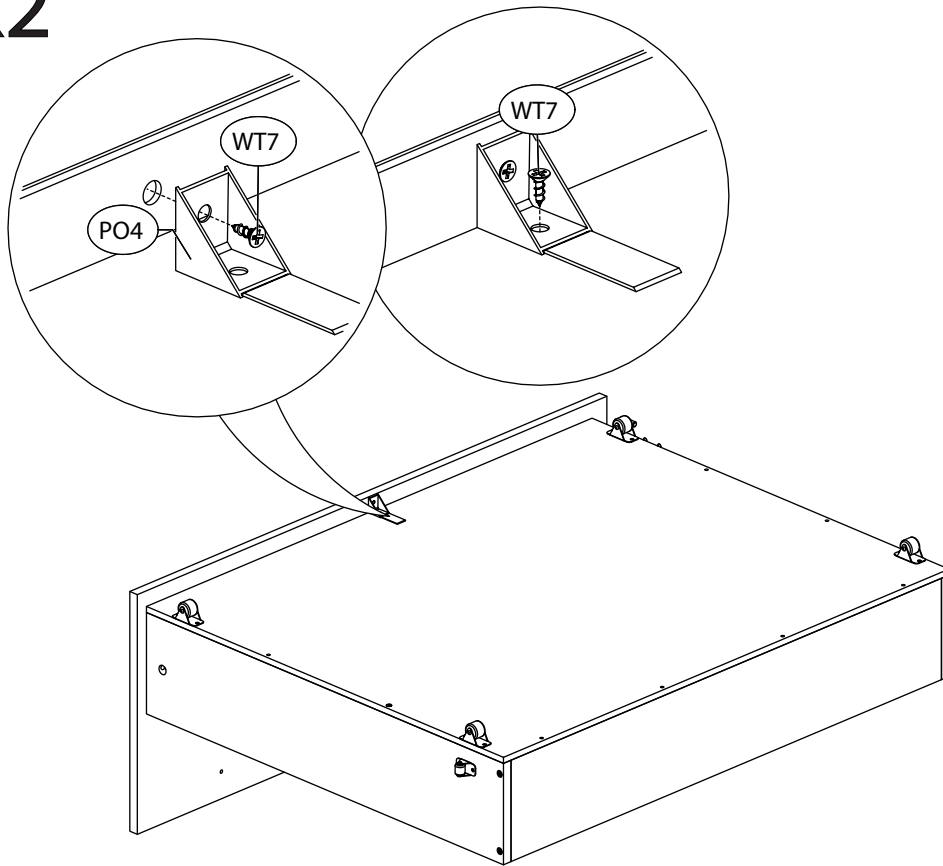

41.

x2

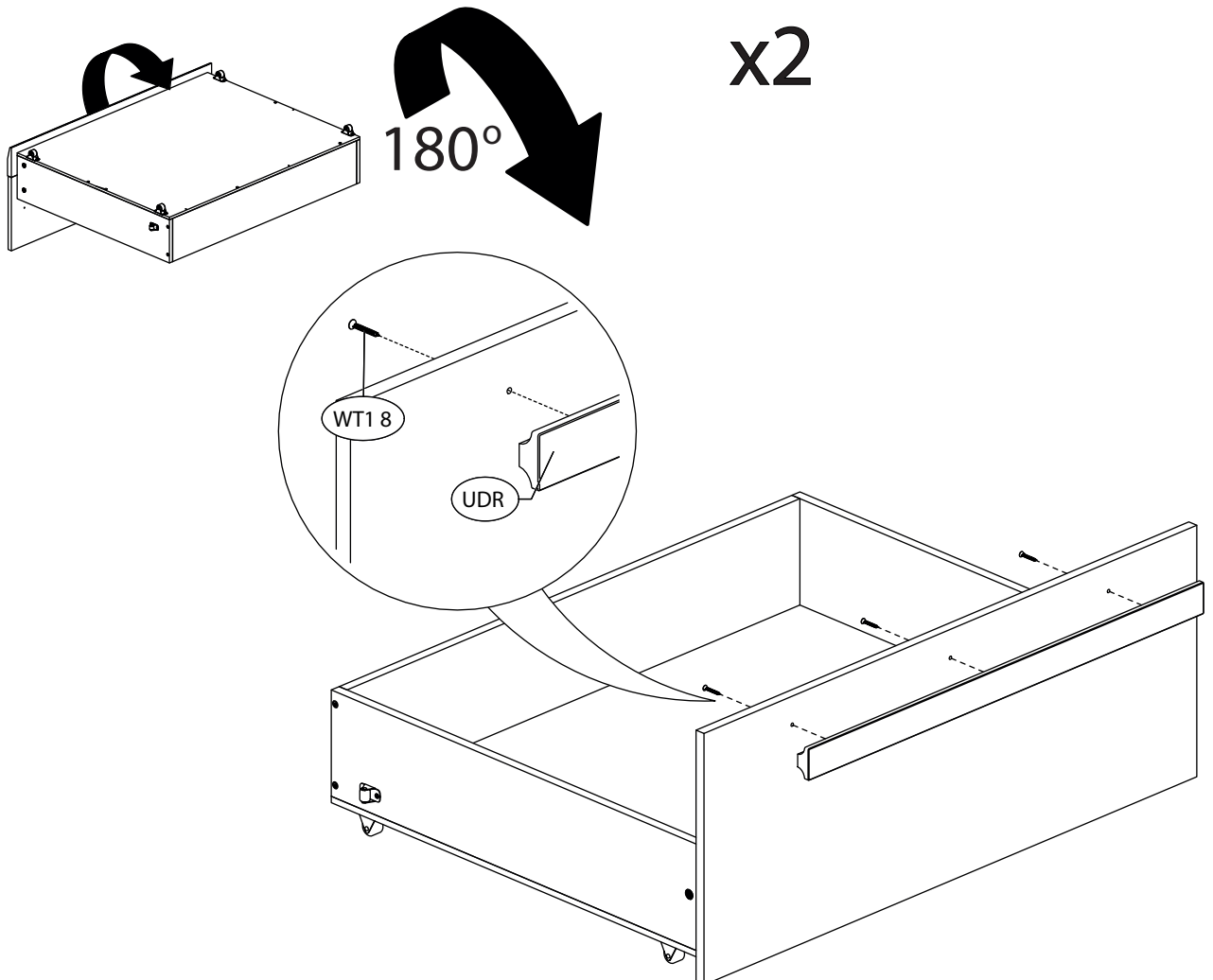

42.

